

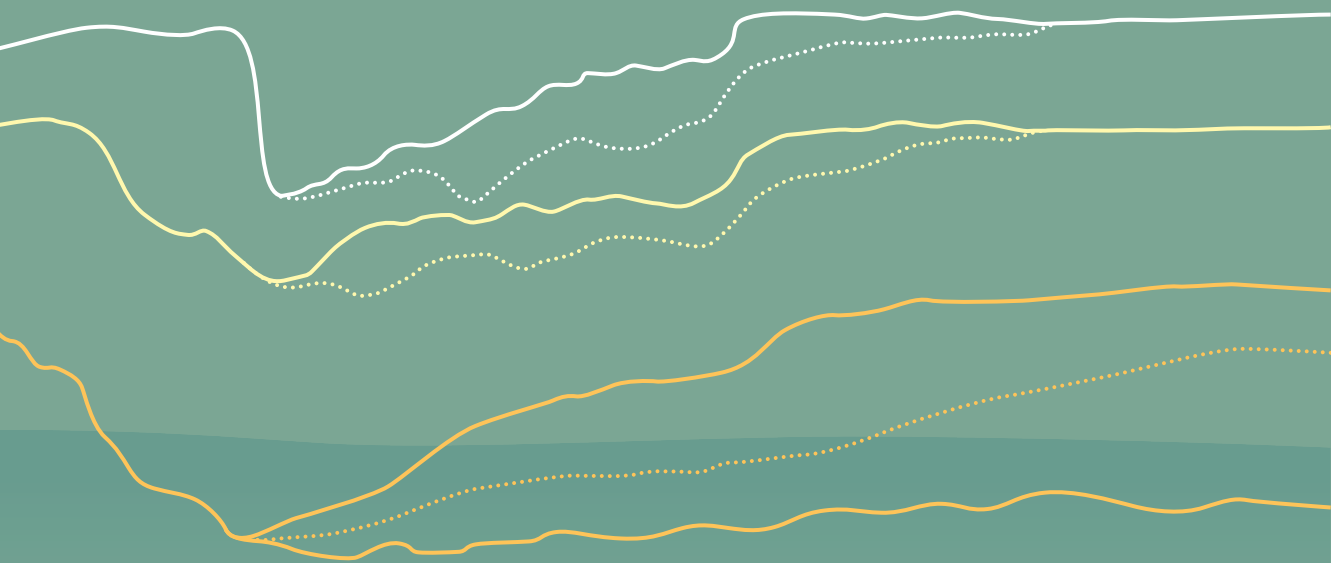

FACTORS INFLUENCING PHYSICAL ACTIVITY BEHAVIOUR OF HOSPITALISED PATIENTS



HANNEKE C. VAN DIJK - HUISMAN

FACTORS INFLUENCING PHYSICAL
ACTIVITY BEHAVIOUR OF
HOSPITALISED PATIENTS

© Hanneke van Dijk – Huisman, Maastricht 2022

No part of this book may be reproduced or transmitted in any form or by any means, without prior permission in writing by the author, or when appropriate, by the publishers of the publications.

Cover design: www.zonderfratsen.com

Layout: Tiny Wouters

Production: Drukkerij Walters

ISBN: 978-94-92741-68-4

The printing of this thesis was financially supported by the Scientific College Physical Therapy (WCF) of the Royal Dutch Society for Physical Therapy (KNGF), Maastricht University, the Department of Physical Therapy of the Maastricht UMC+, Maastricht Instruments, and the Sint Christophorileen tot Oldehove. Anna Foundation|NOREF also provided financial support for dissemination of this thesis.

Anna
Fonds

Nederlands
Orthopedisch
Research en
Educatie
Fonds

MAASTRICHT
INSTRUMENTS

 Maastricht University

 Maastricht UMC+

FACTORS INFLUENCING PHYSICAL ACTIVITY BEHAVIOUR OF HOSPITALISED PATIENTS

PROEFSCHRIFT

ter verkrijging van de graad van doctor aan de Universiteit Maastricht,
op gezag van de Rector Magnificus, Prof. dr. Pamela Habibović
volgens het besluit van het College van Decanen,
in het openbaar te verdedigen op
vrijdag 16 december 2022 om 10.00 uur

door

Hanneke Corine van Dijk - Huisman

Promotores

Prof. dr. A.F. Lenssen

Prof. dr. R.A. de Bie

Beoordelingscommissie

Prof. dr. C.G. Faber (voorzitter)

Prof. dr. H.H.C.M. Savelberg

Prof. dr. J.M.G.A. Schols

Dr. K. Valkenet (Universitair Medisch Centrum Utrecht)

Prof. dr. P.J. van der Wees (Radboud Universitair Medisch Centrum)

CONTENTS

Chapter 1	General introduction	7
Chapter 2	Barriers and enablers to physical activity in patients during hospital stay: a scoping review	23
Chapter 3	Barriers and enablers to physical activity behaviour in older adults during hospital stay: a qualitative study guided by the theoretical domains framework	47
Chapter 4	Development and internal validation of a prediction model to identify older adults at risk of low physical activity levels during hospitalisation: a prospective cohort study	73
Chapter 5	Smartphone app with an accelerometer enhances patients' physical activity following elective orthopedic surgery: a pilot study	95
Chapter 6	Optimization and validation of a classification algorithm for assessment of physical activity in hospitalized patients	121
Chapter 7	General discussion	155
Addendum	Impact paragraph	175
	Summary	181
	Samenvatting	187
	About the author	193
	Dankwoord	197
	List of publications	209

The background of the page features a stylized mountain range. The mountains are rendered in various shades of green, with the foreground mountains in a darker, muted green and the background mountains in a lighter, pale green. The peaks are soft and rounded, creating a serene and naturalistic atmosphere.

CHAPTER ONE

GENERAL INTRODUCTION

INTRODUCTION

Physical activity has been defined as '*any bodily movement produced by skeletal muscles that requires energy expenditure*'¹. It can be undertaken in many different ways, such as walking, cycling, sports and active forms of recreation, domestic tasks around the home, or as part of work². The health benefits of participating in regular physical activity are well established and include a lower risk of cardiovascular disease, hypertension, diabetes, and breast and colon cancer. Additionally, it has positive effects on mental health, delays the onset of dementia, and can help maintain a healthy weight³⁻⁵.

Physical activity behaviour and sedentary behaviour are considered a persons' movement behaviour during waking hours. Physical activity and sedentary behaviour can be performed at different levels of energy expenditure, expressed in Metabolic Equivalent of Task (MET) units. MET units represent the ratio between the energy expenditure of a person performing a certain activity (work metabolic rate) and the energy cost of a person at rest (basal metabolic rate or 1.0 MET). One MET represents the individual use of 3.5 millilitres of oxygen per minute per kilogram body mass⁶. While physical activity is characterised by levels of energy expenditure of >1.5 MET, sedentary behaviour is characterised by an energy expenditure of ≤1.5 MET while sitting, lying or in reclining posture⁷. Sedentary behaviour is also an important determinant of health, independent of physical activity⁸. It is associated with abnormal glucose metabolism, cardiometabolic morbidity, and increased overall mortality⁹.

Since the industrial revolution, the development of new technologies such as cars, televisions, computers and the internet has enabled people to reduce the amount of physical activity and increase the amount of sedentary behaviour in their daily lives. Although such technologies may have many benefits, the human body needs frequent physical activity and should avoid excessive sedentary behaviour in order for many systems (e.g., cardiovascular, metabolic, skeletal, and muscle) to function optimally¹⁰. Physical inactivity has become a worldwide problem, as one in four adults, and three in four adolescents (aged 11-17 years), currently do not meet the global recommendations for physical activity and sedentary behaviour set by the World Health Organization (WHO)¹¹. These guidelines recommend adults to undertake 150-300 minutes of moderate-intensity physical activity or 75-150 minutes of vigorous-intensity physical activity, or some equivalent combination of moderate-intensity and vigorous-intensity aerobic physical activity per week. Furthermore, they recommend performing regular muscle-strengthening activity and reducing sedentary behaviour¹².

The impact of the physical inactivity pandemic is enormous. It is identified as the fourth leading risk factor for global mortality, after high blood pressure, tobacco use and high blood glucose. Physical inactivity levels are rising in many countries with major implications for the prevalence of noncommunicable diseases (e.g., cardiovascular disease, diabetes and cancer) and general health of the population worldwide³. Moreover, the economic burden of physical inactivity is huge, with an estimated global cost of 54 billion international dollars per year in direct healthcare².

Physical activity and sedentary behaviour during hospitalisation

Yearly, more than 1.6 million patients are admitted to hospital for acute care in the Netherlands. Approximately 60% of these patients are admitted with acute conditions and 40% for elective hospital care. The average length of hospital stay is five to six days, and around 44% of all patients are 65 years or older¹³.

Unfortunately, physical inactivity and sedentary behaviour are also prevalent in hospital settings¹⁴. Low amounts of physical activity are common during a hospital stay. On average, patients spend between 87% and 100% of their day lying in bed or sitting in a chair^{15,16}. This inactive behaviour is found in all patient subpopulations, with geriatric inpatients spending on average 30 to 117 minutes standing or walking per day¹⁷⁻²³, compared to 10 to 66 minutes for surgical inpatients²⁴⁻²⁶, 1 to 184 minutes for medical inpatients²⁷⁻³³, 10 to 86 minutes for post-stroke inpatients³⁴⁻³⁹, and 0 minutes for patients admitted to the intensive care unit^{40,41}. Moreover, bouts of standing and walking are usually short and prolonged periods of uninterrupted sedentary behaviour are common^{15,17,42}.

An increasing number of studies have shown that physical inactivity during hospitalisation is associated with a substantial loss of muscle mass⁴³⁻⁴⁵, complications such as pneumonia, pressure ulcers, urinary tract infection, orthostatic instability, deep venous thrombosis⁴⁶⁻⁴⁸, and functional decline⁴⁹⁻⁵². Other negative outcomes associated with physical inactivity during hospitalisation are an increased length of hospital stay^{53,54}, an increased risk of institutionalisation^{29,50,55,56}, and mortality^{19,21,52,55,57}. Previous research has shown that these negative health outcomes can be counteracted by improving patients' physical activity behaviour during hospitalisation. Higher physical activity levels are associated with a reduction in functional decline, length of hospital stay, risk of institutionalisation, mortality and a 30-day readmission risk^{18,21,55,58-64}. To improve outcomes and reduce healthcare costs, it is therefore essential that patients remain as active during hospitalisation as their abilities allow⁶⁵.

Internationally, awareness of physical inactivity amongst hospitalised patients is increasing⁶⁶. In recent years, many initiatives have been launched aimed at

promoting physical activity and reducing sedentary behaviour in patients during hospitalisation. In 2017, the social media campaign “*End-PJ-Paralysis*” was launched in the United Kingdom. This global movement aims to get patients out of bed, dressed in their own clothes and when possible, moving about rather than lying in bed. The “*End-PJ-Paralysis*” campaign raises awareness amongst healthcare professionals worldwide and encourages them to consider how they could promote physical activity in hospitalised patients^{14,66,67}. Furthermore, Johns Hopkins Hospital in Baltimore, U.S.A., has created the “*Activity and Mobility Promotion*” program through which they aim to support healthcare professionals and hospitals that want to change the culture of patient immobility. Other international programs that amongst others promote mobilization in acute-care hospitals are “*Eat Walk Engage*” in Australia and “*Mobilization of Vulnerable Elders (MOVE)*” in Canada^{63,68}.

In the Netherlands, the topic is also gaining increasing attention. Over the last decade, nine Dutch hospitals have initiated innovative and multifaceted projects aimed at promoting physical activity and reducing sedentary behaviour. Examples of these projects are “*Zorg dat u beweegt*” in Maastricht University Medical Center (MUMC+), “*Ban Bedcentricity*” in Radboud university medical center, “*Hospital in Motion*” in University Medical Center Utrecht, and “*Better by Moving*” in Amsterdam University Medical Center. As these nine ‘pioneering’ hospitals were working towards the same goal, they collaborated and created the “*Beweegziekenhuizen*” movement. Instead of competing, they aim to inspire and strengthen each other by sharing their knowledge and experiences. Moreover, they collaborate in research, development and implementation of innovative interventions, and share their experiences with other Dutch hospitals.

Factors influencing patients’ physical activity behaviour during hospitalisation

The physical activity behaviour of hospitalised patients may be influenced by many different factors^{65,69-75}. During hospital stay, patients are temporarily taken out of their own environment. At home, they have their own daily routines which may include going to work, performing household activities, and participating in sports- and social activities. Upon hospital admission, patients enter an unfamiliar environment in which they may miss their usual daily routines. They may feel unwell due to their illness or accompanying symptoms, and may be dependent on healthcare professionals to receive care. As such, a hospital admission can be associated with many uncertainties and insecurities. For many patients, their main focus is the reason for hospital admittance, and less attention is focussed on being physically active.

The hospital environment is not primarily designed to promote physical activity. During a hospital stay, patients will predominantly remain in their room, a safe

space consisting of a bed, night stand, chair and closet. Most rooms offer limited space to walk around with a walking aid and/or an IV-pole, and the television is usually hanging right above the bed. Moreover, the ward and hospital setting are often described as boring and unattractive. The availability of places such as a common room, exercise room, coffee corner, art exhibition or garden tend to stimulate patients to get active.

The hospital culture also has an inactivating effect on patients. Many care processes are concentrated around the hospital bed, with patients waiting for physician and nursing rounds, examinations or distribution of food and medication. As a result, patients adopt a passive role and remain in their room, waiting for healthcare professionals to inform them about what is going to happen. Moreover, many patients believe that rest is needed for recovery, and awareness of the positive effects of physical activity is often lacking.

Healthcare professionals may have an important role in promoting physical activity, amongst others through providing information, promoting independence in self-care and encouraging and assisting patients. However, although many healthcare professionals intend to mobilise patients, they are often limited by time and staffing. Furthermore, visitors may also have an important influence on patients' physical activity behaviour. During visiting hours, patients usually remain in bed because otherwise there are not enough chairs available for visitors. Visitors may be hesitant to take patients for a walk, as they often do not know what patients are allowed to do. On the other hand, visitors could also actively participate in promoting physical activity by assisting patients in walking and exercising.

As shown, many factors may influence patients' physical activity behaviour, and these factors may differ between patient populations, settings and cultures^{65,69-74}. Since interventions aimed at promoting physical activity and decreasing sedentary behaviour are more likely to be effective if they are designed to target underlying factors that influence behaviour, gaining a comprehensive understanding of the barriers and enablers that influence patients' physical activity behaviour during hospitalisation is a first step towards identifying potentially modifiable factors and developing, evaluating and implementing targeted interventions^{72,76,77}.

Older adults admitted with an acute medical illness

Older adults admitted to hospital with an acute medical illness are at increased risk of negative outcomes associated with physical inactivity. With increasing age, their adaptive capacity gradually decreases⁷⁸. A high prevalence of multi-morbidity and age-related impairments make them vulnerable, especially during an acute hospital admission⁴⁹. Functional decline is a common problem amongst older adults during hospitalisation, and is described as '*the loss of ability to independently perform one*

or more basic activities of daily living, namely transferring from bed to chair, walking, climbing stairs, dressing, bathing and using the toilet^{79,80}. Patients' illness or comorbidities may have already elicited functional decline before hospital admission. During hospitalisation, functional decline is also associated with inactivity, even after correcting for illness severity or comorbidities^{17,52,55}. Although some patients are able to recover to their pre-existing levels of physical functioning at discharge, 30% to 60% of older adults are discharged with a disability in one or more activities of daily living that they did not have before admission^{50,54,56,57,79}. This percentage strongly varies due to differences in measurement methods, illness and risk factors⁸¹. One year following discharge, less than 50% of these patients have recovered to their pre-existing levels of physical functioning^{50,54}.

On average, older adults admitted to hospital with an acute medical illness spent between 30 and 117 minutes standing or walking per day, the remainder of the day is spent lying in bed or sitting in a chair¹⁷⁻²³. If older adults at high risk for physical inactivity could be identified early after admission, they could be given targeted interventions aimed at improving physical activity and reducing sedentary behaviour. Creating an adequate risk stratification that enables the identification of older adults at high risk of physical inactivity can therewith contribute to improved patient outcomes.

Measuring physical activity behaviour during hospitalisation

In order to evaluate and promote patients' physical activity behaviour in daily clinical practise, it is essential that physical activity is measured in a way that is accurate, clinically meaningful, and does not increase the workload of healthcare professionals^{15,82}. In current clinical practice, mobility assessments typically measure patients' highest level of functioning, the ability to perform activities of daily living, or level of assistance required. Outcomes are documented in the electronic health record roughly once per day, therewith providing only limited estimates of patients' daily physical activity behaviour. Objective, quantitative assessments of patients' physical activity behaviour would be of added value, but are rarely integrated in clinical practice yet¹⁵. Moreover, previous studies also show a substantial heterogeneity in methods and outcome parameters used to measure physical activity^{15,16}.

Commonly used methods to measure physical activity behaviour during hospitalisation are self-reported measures, behaviour mapping or wearable activity monitors^{15,83}. Self-reported measures (e.g., surveys or diaries) are subjective and show low validity and reliability⁸³⁻⁸⁵. Behaviour mapping involves direct, structured observation and classification of patients' physical activity behaviour by observers^{86,87}. This is labour-intensive and may intrude upon patients' privacy^{82,88}. Furthermore, it may under-, or overestimate time spent in activities when

observations are performed during working-hours only, or when sampled at intervals (e.g., one minute in every ten minutes)^{29,82,88,89}. Short bouts of walking, which are common in hospitalised patients, may therefore not be recorded. Wearable activity monitors (e.g., pedometers or accelerometers) allow for objective, continuous quantification and classification of patients' physical activity behaviour over longer time periods^{15,42,82,90,91}. Moreover, they require less effort and invasiveness than behaviour mapping. Accelerometers measure raw accelerations obtained from movements of a body or body segment. Physical activity behaviour is then estimated by applying an algorithm to the raw data⁹². The performance of accelerometers is determined by this algorithm, the sensor wear location, the number of sensors used, and the characteristics of the person wearing the accelerometer (e.g., age, walking speed, gait pattern) and chosen outcome parameters (classification of activities, step count or intensity)^{82,83}.

Most accelerometer algorithms are validated in healthy adults and lack sensitivity to classify slow or impaired gait^{93,94}. In order to integrate the use of accelerometers into daily clinical practise, it is important that they are validated in hospitalised patients. Previous studies have shown that the validity of existing algorithms to classify time spent in dynamic activities and the classification of postural transitions in hospitalised patients varies and is often investigated in small study samples^{19,87-89,95-99}. A suitable algorithm for hospitalised patients that is able to discriminate between standing and dynamic activities, as well as to classify postural transitions, would be of added value to improve physical activity monitoring in hospitalised patients¹⁰⁰.

The potential of mHealth to monitor physical activity in clinical practise

Although accelerometers offer objective, quantitative assessment of patients' physical activity behaviour, they do not provide direct feedback to patients or healthcare professionals. To gain insight in patients' physical activity behaviour, the data first has to be uploaded to a computer. This may not be an issue when data is gathered for research purposes. However, when using physical activity monitoring in clinical practice, real-time feedback is needed. This enables healthcare professionals to effectively advise patients on their physical activity behaviour. mHealth could provide a solution to this problem¹⁰¹. mHealth has been defined by the WHO as '*medical and public health practice supported by mobile devices, such as smartphones, tablets or wireless patient-monitoring sensors*'^{101,102}. Connecting an accelerometer to a smartphone via Bluetooth enables continuous physical activity monitoring with the advantage of providing patients and healthcare professionals real-time feedback. To enhance the possibilities, additional functionalities such as educational material or exercise programs could also be added to such mHealth tools. Previous research has shown that smartphone applications combined with an

activity tracker are able to improve physical activity in other populations^{103,104}. Additionally, mHealth tools can be used to increase patient awareness, stimulate self-management and support personalised healthcare^{103,105,106}. As a result, they show great potential to offer hospitalised patients and their healthcare professionals' essential strategies to improve their physical activity behaviour and support their recovery process.

PERSONAL MOTIVATION

During my work as a clinical physiotherapist I am confronted with the inactivating hospital environment on a daily basis. Having worked in three different hospitals and at many different wards, I experienced that this is not specific to a single setting. Promoting patients' physical activity behaviour during hospitalisation is often attributed to the physiotherapist. However, patients' physical activity and sedentary behaviour are influenced by many other factors during hospitalisation. To decrease the negative effects associated with inactivity, hospitals should aim to change from an inactivating to a (re)activating hospital culture.

A few years ago, the Department of Physiotherapy of the MUMC+ aimed to improve the process of promoting physical activity and enhancing functional recovery in hospitalised patients. They wanted to increase patients' awareness, provide personalized care, and stimulate self-management. To accomplish this, they wanted to enable objective physical activity monitoring, provide patients insight in their recovery, and offer a tailored exercise program. In 2016, this resulted in the development Hospital Fit, a smartphone app connected to an accelerometer. Due to the close collaboration between the hospital, the Faculty of Health, Medicine & Life Sciences of Maastricht University and Maastricht Instruments B.V., MUMC+ is an optimal setting to develop and investigate Hospital Fit, and to combine research and innovation with clinical practice. Therefore, this PhD research project was a logical next step following the initiation of Hospital Fit. The aims of this research project were to contribute to improving patients' physical activity behaviour during hospitalisation, amongst others through assisting in the development, evaluation and implementation of Hospital Fit. The combination of working as a clinical physiotherapist and researcher provided a perfect opportunity to continuously gather new insights and knowledge by collecting, analysing, and interpreting data gathered in daily clinical practise. Working as an embedded scientists provided the opportunity to contribute to improved healthcare through translating research findings into clinical practise.

AIMS AND OUTLINE OF THIS THESIS

The main aim of this thesis is to contribute to improving patients' physical activity behaviour during hospitalisation. In Chapter 2 a scoping review was performed to identify patient- and healthcare professional reported barriers and enablers to physical activity during a hospital stay for acute care, and to categorise them using the Theoretical Domains Framework (TDF). In Chapter 3 a qualitative study was conducted to explore patient- and healthcare professional perceived barriers and enablers to physical activity in older adults admitted to a hospital with an acute medical illness, and to categorise them using the TDF. In Chapter 4 two prediction models were developed and internally validated that can be used to predict the probability of low physical activity levels during hospitalisation for older adults admitted to hospital with an acute medical illness. Chapter 5 investigated whether the introduction of Hospital Fit as part of the physiotherapy treatment had resulted in a change in physical activity levels of hospitalised patients following elective orthopaedic surgery. Chapter 6 describes the optimisation and validation of a physical activity classification algorithm which is able to discriminate between sedentary, standing, and dynamic activities, and to detect postural transitions among hospitalised patients under free-living conditions. Finally, Chapter 7 provides a general discussion of the most important findings of the included studies. In addition, implications for clinical practice and recommendations for future research are discussed.

REFERENCES

1. Caspersen CJ, Powell KE, Christenson GM. Physical activity, exercise, and physical fitness: definitions and distinctions for health-related research. *Public health reports* (Washington, DC : 1974). 1985;100(2): 126-31.
2. WHO. Global action plan on physical activity 2018-2030: more active people for a healthier world. Geneva: World Health Organization; 2018.
3. WHO. Global recommendations on physical activity for health. Geneva: World Health Organization; 2010.
4. Physical Activity Guidelines Advisory Committee report, 2008. To the Secretary of Health and Human Services. Part A: executive summary. *Nutr Rev*. 2009;67(2):114-20.
5. Sallis JF, Bull F, Guthold R, Heath GW, Inoue S, Kelly P, et al. Progress in physical activity over the Olympic quadrennium. *Lancet* (London, England). 2016;388(10051):1325-36.
6. Tremblay MS, Aubert S, Barnes JD, Saunders TJ, Carson V, Latimer-Cheung AE, et al. Sedentary Behavior Research Network (SBRN) - Terminology Consensus Project process and outcome. *Int J Behav Nutr Phys Act*. 2017;14(1):75.
7. Sedentary-Behavior-Research-Network. Letter to the editor: standardized use of the terms "sedentary" and "sedentary behaviors". *Appl Physiol Nutr Metab*. 2012;37: 540-2.
8. de Rezende LF, Rodrigues Lopes M, Rey-López JP, Matsudo VK, Luiz Odo C. Sedentary behavior and health outcomes: an overview of systematic reviews. *PLoS One*. 2014;9(8):e105620.
9. Owen N, Healy GN, Matthews CE, Dunstan DW. Too much sitting: the population health science of sedentary behavior. *Exerc Sport Sci Rev*. 2010;38(3):105-13.
10. Hallal PC, Andersen LB, Bull FC, Guthold R, Haskell W, Ekelund U. Global physical activity levels: surveillance progress, pitfalls, and prospects. *Lancet* (London, England). 2012;380(9838):247-57.
11. Guthold R, Stevens GA, Riley LM, Bull FC. Worldwide trends in insufficient physical activity from 2001 to 2016: a pooled analysis of 358 population-based surveys with 1.9 million participants. *Lancet Glob Health*. 2018;6(10):e1077-e86.
12. Bull FC, Al-Ansari SS, Biddle S, Borodulin K, Buman MP, Cardon G, et al. World Health Organization 2020 guidelines on physical activity and sedentary behaviour. *Br J Sports Med*. 2020;54(24):1451-62.
13. Van Dijk-Huisman HC. CBS. StatLine - Ziekenhuisopnamen; sterfte, urgentie, diagnose-indelingen CCS en VTV 2021 [Available from: <https://www.cbs.nl>]
14. Chastin SFM, Harvey, J.A., Dall, P.M.,McInally, L., Mavroei, A., Skelton, D.A. Beyond "#endpjaralysis", tackling sedentary behaviour in health care. *AIMS Medical Science*. 2019;6(1):67-75.
15. Fazio S, Stocking J, Kuhn B, Doroy A, Blackmon E, Young HM, et al. How much do hospitalized adults move? A systematic review and meta-analysis. *Appl Nurs Res: ANR*. 2020;51:151189.
16. Baldwin C, van Kessel G, Phillips A, Johnston K. Accelerometry Shows Inpatients With Acute Medical or Surgical Conditions Spend Little Time Upright and Are Highly Sedentary: Systematic Review. *Phys Ther*. 2017;97(11):1044-65.
17. Evensen SS, O; Lydersen, S.; Taraldsen, K. Physical activity among hospitalized older adults - an observational study. *BMC Geriatr*. 2017;17:110.
18. Fisher SR, Goodwin JS, Protas EJ, Kuo YF, Graham JE, Ottenbacher KJ, et al. Ambulatory activity of older adults hospitalized with acute medical illness. *J Am Geriatr Soc*. 2011;59(1):91-5.
19. Pedersen MMB, A.C.; Petersen, J.; Beyers, N.; Andersen, O.; Lawson-Smith, L.; Kehlet, H.; Bandholm, T. Twenty-four-hour mobility during acute hospitalization in older medical patients. *J Gerontol A Biol Sci Med Sci*. 2013;68:331-7.
20. Villumsen M, Jorgensen MG, Andreassen J, Rathleff MS, Mølgaard CM. Very Low Levels of Physical Activity in Older Patients During Hospitalization at an Acute Geriatric Ward: A Prospective Cohort Study. *J Aging Phys Act*. 2015;23(4):542-9.
21. Ostir GV, Berges IM, Kuo YF, Goodwin JS, Fisher SR, Guralnik JM. Mobility activity and its value as a prognostic indicator of survival in hospitalized older adults. *J Am Geriatr Soc*. 2013;61(4):551-7.
22. Hartley P, DeWitt AL, Forsyth F, Romero-Ortuno R, Deaton C. Predictors of physical activity in older adults early in an emergency hospital admission: a prospective cohort study. *BMC Geriatr*. 2020;20(1):177.

23. Pavon JM, Sloane RJ, Pieper CF, Colón-Emeric CS, Cohen HJ, Gallagher D, et al. Accelerometer-Measured Hospital Physical Activity and Hospital-Acquired Disability in Older Adults. *J Am Geriatr Soc*. 2020;68(2):261-5.
24. Browning L, Denehy L, Scholes RL. The quantity of early upright mobilisation performed following upper abdominal surgery is low: an observational study. *Aust J Physiother*. 2007;53(1):47-52.
25. Davenport SJ, Arnold M, Hua C, Schenck A, Batten S, Taylor NF. Physical Activity Levels During Acute Inpatient Admission After Hip Fracture are Very Low. *Physiother Res Int*. 2015;20(3):174-81.
26. Taraldsen K, Sletvold O, Thingstad P, Saltvedt I, Granat MH, Lydersen S, et al. Physical behavior and function early after hip fracture surgery in patients receiving comprehensive geriatric care or orthopedic care--a randomized controlled trial. *J Gerontol A Biol Sci Med Sci*. 2014;69(3):338-45.
27. Borges RC, Carvalho CR, Colombo AS, da Silva Borges MP, Soriano FG. Physical activity, muscle strength, and exercise capacity 3 months after severe sepsis and septic shock. *Intensive Care Med*. 2015;41(8):1433-44.
28. Borges RC, Carvalho CR. Physical activity in daily life in Brazilian COPD patients during and after exacerbation. *COPD*. 2012;9(6):596-602.
29. Brown CJ RD, Flood KL, Allman RM. The underrecognized epidemic of low mobility during hospitalization of older adults. *J Am Geriatr Soc*. 2009;57(9):1660-5.
30. Cattanach N, Sheedy R, Gill S, Hughes A. Physical activity levels and patients' expectations of physical activity during acute general medical admission. *Intern Med J*. 2014;44(5):501-4.
31. Howie-Esquivel J, Zaharias E. Using Novel Technology to Determine Mobility Among Hospitalized Heart Failure Patients: A Pilot Study. *Cardiol Res*. 2013;4(1):15-25.
32. Kuys SS, Dolecka UE, Guard A. Activity level of hospital medical inpatients: an observational study. *Arch Gerontol Geriatr*. 2012;55(2):417-21.
33. Mudge AM, McRae P, McHugh K, Griffin L, Hitchen A, Walker J, et al. Poor mobility in hospitalized adults of all ages. *J Hosp Med*. 2016;11(4):289-91.
34. Askim T, Bernhardt J, Churilov L, Fredriksen KR, Indredavik B. Changes in physical activity and related functional and disability levels in the first six months after stroke: a longitudinal follow-up study. *J Rehabil Med*. 2013;45(5):423-8.
35. Prakash V, Shah MA, Hariohm K. Family's presence associated with increased physical activity in patients with acute stroke: an observational study. *Braz J Phys Ther*. 2016;20(4):306-11.
36. King A, McCluskey A, Schurr K. The time use and activity levels of inpatients in a co-located acute and rehabilitation stroke unit: an observational study. *Top Stroke Rehabil*. 2011;18 Suppl 1:654-65.
37. Kramer SF, Churilov L, Kroeders R, Pang MY, Bernhardt J. Changes in activity levels in the first month after stroke. *J Phys Ther Sci*. 2013;25(5):599-604.
38. Kunkel D, Fitton C, Burnett M, Ashburn A. Physical inactivity post-stroke: a 3-year longitudinal study. *Disabil Rehabil*. 2015;37(4):304-10.
39. Hokstad A, Indredavik B, Bernhardt J, Ihle-Hansen H, Salvesen Ø, Seljeseth YM, et al. Hospital differences in motor activity early after stroke: a comparison of 11 Norwegian stroke units. *J Stroke Cerebrovasc Dis*. 2015;24(6):1333-40.
40. Berney SC, Rose JW, Bernhardt J, Denehy L. Prospective observation of physical activity in critically ill patients who were intubated for more than 48 hours. *J Crit Care*. 2015;30(4):658-63.
41. Connolly BA, Mortimore JL, Douiri A, Rose JW, Hart N, Berney SC. Low Levels of Physical Activity During Critical Illness and Weaning: The Evidence-Reality Gap. *J Intensive Care Med*. 2019;34(10):818-27.
42. Baldwin CE, Parry SM, Norton L, Williams J, Lewis LK. A scoping review of interventions using accelerometers to measure physical activity or sedentary behaviour during hospitalization. *Clin Rehabil*. 2020;34(9):1157-72.
43. Parry SM, Puthuchearry ZA. The impact of extended bed rest on the musculoskeletal system in the critical care environment. *Extrem Physiol Med*. 2015;4:16.
44. Winkelman C. Bed rest in health and critical illness: a body systems approach. *AACN Adv Crit Care*. 2009;20(3):254-66.
45. Kortebein P, Ferrando A, Lombeida J, Wolfe R, Evans WJ. Effect of 10 days of bed rest on skeletal muscle in healthy older adults. *JAMA*. 2007;297(16):1772-4.
46. Knight J, Nigam Y, Jones A. Effects of bedrest 1: cardiovascular, respiratory and haematological systems. *Nurs Times*. 2009;105(21):16-20.

47. Knight J, Nigam Y, Jones A. Effects of bedrest 2: gastrointestinal, endocrine, renal, reproductive and nervous systems. *Nurs Times*. 2009;105(22):24-7.
48. Nigam Y, Knight J, Jones A. Effects of bedrest 3: musculoskeletal and immune systems, skin and self-perception. *Nurs Times*. 2009;105(23):18-22.
49. Buurman BM, Hoogerduijn JG, de Haan RJ, Abu-Hanna A, Lagaay AM, Verhaar HJ, et al. Geriatric conditions in acutely hospitalized older patients: prevalence and one-year survival and functional decline. *PLoS One*. 2011;6(11):e26951.
50. Boyd CM, Landefeld CS, Counsell SR, Palmer RM, Fortinsky RH, Kresevic D, et al. Recovery of activities of daily living in older adults after hospitalization for acute medical illness. *J Am Geriatr Soc*. 2008;56(12):2171-9.
51. Zisberg A, Syn-Hershko A. Factors related to the mobility of hospitalized older adults: A prospective cohort study. *Geriatr Nurs*. 2016;37(2):96-100.
52. Zisberg A, Shadmi E, Sinoff G, Gur-Yaish N, Srulovici E, Admi H. Low mobility during hospitalization and functional decline in older adults. *J Am Geriatr Soc*. 2011;59(2):266-73.
53. Abeles A, Kwasnicki RM, Pettengell C, Murphy J, Darzi A. The relationship between physical activity and post-operative length of hospital stay: A systematic review. *Int J Surg*. 2017;44:295-302.
54. Covinsky KE, PE, Jonston CB. Hospitalization - associated disability: She was probably able to ambulate, but I'm not sure". *JAMA*. 2011;306(16):1782-93.
55. Brown CJ, Friedkin RJ, Inouye SK. Prevalence and outcomes of low mobility in hospitalized older patients. *J Am Geriatr Soc*. 2004;52(8):1263-70.
56. Mahoney JE, Sager MA, Jalaluddin M. Use of an ambulation assistive device predicts functional decline associated with hospitalization. *J Gerontol A Biol Sci Med Sci*. 1999;54(2):M83-8.
57. Covinsky KE, Palmer RM, Fortinsky RH, Counsell SR, Stewart AL, Kresevic D, et al. Loss of independence in activities of daily living in older adults hospitalized with medical illnesses: increased vulnerability with age. *J Am Geriatr Soc*. 2003;51(4): 451-8.
58. Zisberg A, Shadmi E, Gur-Yaish N, Tonkikh O, Sinoff G. Hospital-associated functional decline: the role of hospitalization processes beyond individual risk factors. *J Am Geriatr Soc*. 2015;63(1):55-62.
59. Agmon M, Zisberg A, Gil E, Rand D, Gur-Yaish N, Azriel M. Association Between 900 Steps a Day and Functional Decline in Older Hospitalized Patients. *JAMA Int Med*. 2017;177(2):272-4.
60. Padula CA, Hughes C, Baumhover L. Impact of a nurse-driven mobility protocol on functional decline in hospitalized older adults. *J Nurs Care Qual*. 2009;24(4):325-31.
61. McCullagh R, Dillon C, Dahly D, Horgan NF, Timmons S. Walking in hospital is associated with a shorter length of stay in older medical inpatients. *Physiol Meas*. 2016;37(10):1872-84.
62. Fisher SR, Kuo YF, Graham JE, Ottenbacher KJ, Ostir GV. Early ambulation and length of stay in older adults hospitalized for acute illness. *Arch Intern Med*. 2010;170(21):1942-3.
63. Liu B, Moore JE, Almaawiy U, Chan WH, Khan S, Ewusie J, et al. Outcomes of Mobilisation of Vulnerable Elders in Ontario (MOVE ON): a multisite interrupted time series evaluation of an implementation intervention to increase patient mobilisation. *Age Ageing*. 2018;47(1):112-9.
64. Fisher SR, Graham JE, Ottenbacher KJ, Deer R, Ostir GV. Inpatient Walking Activity to Predict Readmission in Older Adults. *Arch Phys Med Rehabil*. 2016;97(9 Suppl):S226-31.
65. So C, Pierluissi E. Attitudes and expectations regarding exercise in the hospital of hospitalized older adults: a qualitative study. *J Am Geriatr Soc*. 2012;60(4):713-8.
66. Crabtree A, Lane, T.J., Mahon, L., Petch, T., Ekegren, C.L. The impact of an End-PJ-Paralysis quality improvement intervention in post-acute care: an interrupted time series analysis. *AIMS Med Sci*. 2021;8(1):23-5.
67. Oliver D. David Oliver: Fighting pyjama paralysis in hospital wards. *BMJ*. 2017;357:j2096.
68. Mudge AM, McRae P, Cruickshank M. Eat walk engage: an interdisciplinary collaborative model to improve care of hospitalized elders. *Am J Med Qual*. 2015;30(1):5-13.
69. Brown CJ, Williams BR, Woodby LL, Davis LL, Allman RM. Barriers to mobility during hospitalization from the perspectives of older patients and their nurses and physicians. *J Hosp Med*. 2007;2(5):305-13.
70. Boltz M, Capezuti E, Shabbat N. Nursing staff perceptions of physical function in hospitalized older adults. *Appl Nurs Res*. 2011;24(4):215-22.
71. Doherty-King B, Bowers B. How nurses decide to ambulate hospitalized older adults: development of a conceptual model. *Gerontologist*. 2011;51(6):786-97.

72. Moore JE, Mascarenhas A, Marquez C, Almaawiy U, Chan WH, D'Souza J, et al. Mapping barriers and intervention activities to behaviour change theory for Mobilization of Vulnerable Elders in Ontario (MOVE ON), a multi-site implementation intervention in acute care hospitals. *Implement Sci*. 2014;9:160.
73. De Klein K, Valkenet K, Veenhof C. Perspectives of patients and health-care professionals on physical activity of hospitalized patients. *Physiother Theory Pract*. 2021;37(2):307-14.
74. Boltz M, Capezuti E, Shabbat N, Hall K. Going home better not worse: older adults' views on physical function during hospitalization. *Int J Nurs Pract*. 2010;16(4):381-8.
75. Hoyer EH, Brotman DJ, Chan KS, Needham DM. Barriers to early mobility of hospitalized general medicine patients: survey development and results. *Am J Phys Med Rehabil*. 2015;94(4):304-12.
76. Dermody G, Kovach CR. Barriers to Promoting Mobility in Hospitalized Older Adults. *Res Gerontol Nurs*. 2018;11(1):17-27.
77. Michie S JM, Francis J, Hardeman W, Eccles M. From Theory to Intervention: Mapping Theoretically Derived Behavioural Determinants to Behaviour Change Techniques. *Appl Psychol*. 2008 57(4):660 - 80.
78. Hoozeboom TJD, J.J.; Hulzebos, E.H.; van Meeteren, N.L. Merits of exercise therapy before and after major surgery. *Curr Opin Anaesthesiol*. 2014;27.
79. Hoogerduijn JG, Schuurmans MJ, Duijnste MS, de Rooij SE, Grypdonck MF. A systematic review of predictors and screening instruments to identify older hospitalized patients at risk for functional decline. *J Clin Nurs*. 2007;16(1):46-57.
80. Wood W, Tschannen D, Trotsky A, Grunawalt J, Adams D, Chang R, et al. A mobility program for an inpatient acute care medical unit. *Am J Nurs*. 2014;114(10):34-40; quiz 1-2.
81. Buurman B.M. dRSE. Functieverlies ouderen bij acute opname in ziekenhuis. *Ned Tijdschr Geneesk*. 2015;159: A8185.
82. Lim SER, Ibrahim K, Sayer AA, Roberts HC. Assessment of Physical Activity of Hospitalised Older Adults: A Systematic Review. *J Nutr Health Aging*. 2018;22(3):377-86.
83. Cheung VH, Gray L, Karunanithi M. Review of accelerometry for determining daily activity among elderly patients. *Arch Phys Med Rehabil*. 2011;92(6):998-1014.
84. Berendsen BAH, M.R.; Meijer, K.; Plasqui, G.; Schaper, N.C.; Savelberg, H.H. . Which activity monitor to use? Validity, reproducibility and user friendliness of three activity monitors. *BMC Public Health*. 2014;14:749.
85. Lindemann U ZW, Aminian K, Chastin S, de Bruin E, Helbostad J, Bussmann J. Recommendations for standardizing validation procedures assessing physical activity of older persons by monitoring body postures and movements. *Sensors*. 2014;14:1267-77.
86. van Delft L, Bor P, Valkenet K, Slooter A, Veenhof C. The Effectiveness of Hospital in Motion, a Multidimensional Implementation Project to Improve Patients' Movement Behavior During Hospitalization. *Phys Ther*. 2020.
87. Kramer SF, Cumming T, Churilov L, Bernhardt J. Measuring activity levels at an acute stroke ward: comparing observations to a device. *Biomed Res Int*. 2013;2013:460482.
88. Baldwin CE JK, Rowlands AV, Williams MT, . Physical activity of ICU survivors during acute admission: Agreement of the activPAL with observation. *Physiotherapy Canada*. 2018;70(1):57-63.
89. Brown CJ RD, Allman RM. Validation of use of wireless monitors to measure levels of mobility during hospitalization. *J Rehabil Res Develop*. 2008;45(4):551-8.
90. Bijmens W AJ, Stevens A, Ummels D, Meijer K. Optimization and validation of an adjustable activity classification algorithm for assessment of physical behavior in elderly. *Sensors*. 2019;19:5344.
91. Ainsworth B, Cahalin L, Buman M, Ross R. The current state of physical activity assessment tools. *Prog Cardiovasc Dis*. 2015;57(4):387-95.
92. Welk GJ, Bai Y, Lee JM, Godino J, Saint-Maurice PF, Carr L. Standardizing Analytic Methods and Reporting in Activity Monitor Validation Studies. *Med Sci Sports Exerc*. 2019;51(8):1767-80.
93. Chen KY, Janz KF, Zhu W, Brychta RJ. Redefining the roles of sensors in objective physical activity monitoring. *Med Sci Sport Exerc*. 2012;44(1 Suppl 1):S13-23.
94. Evenson KR, Goto MM, Furberg RD. Systematic review of the validity and reliability of consumer-wearable activity trackers. *Int J Behav Nutr Phys Act*. 2015;12:159.
95. Valkenet K, Veenhof C. Validity of three accelerometers to investigate lying, sitting, standing and walking. *PLoS One*. 2019;14(5):e0217545.

96. Lipperts M, van Laarhoven S, Senden R, Heyligers I, Grimm B. Clinical validation of a body-fixed 3D accelerometer and algorithm for activity monitoring in orthopaedic patients. *J Orthop Translat.* 2017;11:19-29.
97. Anderson JL YL, Green AJ. A study investigating the validity of an accelerometer in quantification of setp count in adult hospital inpatients recovering from critical illness. *Clin Rehabil.* 2019;33(5):936-42.
98. Taraldsen K, Askim T, Sletvold O, Einarsen EK, Bjastad KG, Indredavik B, et al. Evaluation of a body-worn sensor system to measure physical activity in older people with impaired function. *Phys Ther.* 2011;91(2):277-85.
99. Anderson JL, Green AJ, Yoward LS, Hall HK. Validity and reliability of accelerometry in identification of lying, sitting, standing or purposeful activity in adult hospital inpatients recovering from acute or critical illness: a systematic review. *Clin Rehabil.* 2018;32(2):233-42.
100. Valkenet K, Bor P, van Delft L, Veenhof C. Measuring physical activity levels in hospitalized patients: a comparison between behavioural mapping and data from an accelerometer. *Clin Rehabil.* 2019;33(7):1233-40.
101. Joosen P, Piette D, Buekers J, Taelman J, Berckmans D, De Boever P. A smartphone-based solution to monitor daily physical activity in a care home. *J Telemed Telecare.* 2019;25(10):611-22.
102. WHO. *mHealth: New Horizons for health through mobile technologies.* WHO: Geneva, Switzerland; 2011.
103. Vandelanotte C, Muller AM, Short CE, Hingle M, Nathan N, Williams SL, et al. Past, Present, and Future of eHealth and mHealth Research to Improve Physical Activity and Dietary Behaviors. *J Nutr Educ Behav.* 2016;48(3):219-28.e1.
104. Coughlin SS, Whitehead M, Sheats JQ, Mastromonico J, Smith S. A Review of Smartphone Applications for Promoting Physical Activity. *J Community Med.* 2016;2(1):1-14.
105. van der Weegen S, Verwey R, Spreeuwenberg M, Tange H, van der Weijden T, de Witte L. It's LiFe! Mobile and Web-Based Monitoring and Feedback Tool Embedded in Primary Care Increases Physical Activity: A Cluster Randomized Controlled Trial. *J Med Internet Res.* 2015;17(7):e184.
106. Feldman DI, Theodore Robison W, Pacor JM, Caddell LC, Feldman EB, Deitz RL, et al. Harnessing mHealth technologies to increase physical activity and prevent cardiovascular disease. *Clin Cardiol.* 2018;41(7):985-91.

CHAPTER TWO

BARRIERS AND ENABLERS TO PHYSICAL ACTIVITY IN PATIENTS DURING HOSPITAL STAY: A SCOPING REVIEW

Sven J.G. Geelen*
Hanneke C. van Dijk-Huisman*
Robert A. de Bie
Cindy Veenhof
Raoul H.H. Engelbert
Marieke van der Schaaf**
Antoine F. Lenssen**

* Shared first authorship.

** Shared last authorship

Published in Syst Rev. 2021;10(1):293

Digital Object Identifier: 10.1186/s13643-021-01843-x

ABSTRACT

Background

Low levels of physical activity are common during the hospital stay and have been associated with negative health outcomes. Understanding barriers and enablers to physical activity during a hospital stay can improve the development and implementation of tailored interventions aimed at improving physical activity. Previous studies have identified many barriers and enablers, but a comprehensive overview is lacking. This study aimed to identify and categorize all published patient- and healthcare professional-reported barriers and enablers to physical activity during a hospital stay for acute care, using the Theoretical Domains Framework (TDF).

Methods

We conducted a scoping review of Dutch and English articles using MEDLINE, CINAHL Plus, EMBASE, PsycINFO, and Cochrane Library (inception to September 2020), which included quantitative, qualitative, and mixed-methods studies reporting barriers and enablers to physical activity during a hospital stay for acute care, as perceived by patients or healthcare professionals. Two reviewers systematically extracted, coded, and categorized all barriers and enablers into TDF domains.

Results

Fifty-six articles were included in this review (32 qualitative, 7 quantitative, and 17 mixed-methods). In total, 264 barriers and 228 enablers were reported by patients, and 415 barriers and 409 enablers by healthcare professionals. Patient-reported barriers were most frequently assigned to the TDF domains *Environmental Context & Resources* (ECR, $n=148$), *Social Influences* ($n=32$), and *Beliefs about Consequences* ($n=25$), while most enablers were assigned to ECR ($n=67$), *Social Influences* ($n=54$), and *Goals* ($n=32$). Barriers reported by healthcare professionals were most frequently assigned to ECR ($n=210$), *Memory, Attention and Decision Process* ($n=45$), and *Social/Professional Role & Identity* ($n=31$), while most healthcare professional-reported enablers were assigned to the TDF domains ECR ($n=143$), *Social Influences* ($n=76$), and *Behavioural Regulation* ($n=54$).

Conclusions

Our scoping review presents a comprehensive overview of all barriers and enablers to physical activity during a hospital stay and highlights the prominent role of the TDF domains ECR and *Social Influences* in hospitalized patients' physical activity behavior. This TDF-based overview provides a theoretical foundation to guide clinicians and researchers in future intervention development and implementation.

Contributions to the literature

- Physical inactivity during the hospital stay is a frequent problem, but an overview of patient- and healthcare professional-reported barriers and enablers to physical activity was lacking.
- The majority of barriers and enablers were categorized under the TDF-domains Environmental Context and Resources and Social Influences, highlighting the need for interventions that target the physical environment, hospital care processes, organizational characteristics, resources, patient-related factors, and social influences.
- Our comprehensive theory-informed overview of all published barriers and enablers to physical activity during a hospital stay can assist clinicians and researchers in developing and implementing tailored interventions in local clinical practice.

BACKGROUND

Hospitalized patients spend between 87 and 100% of their time lying in bed or sitting, irrespective of the reason for admission¹. Low levels of physical activity have been associated with negative health outcomes like functional decline^{2,3}, increased length of stay⁴, increased risk of institutionalization^{5,6}, and mortality^{2,3,7,8}. Previous research has shown that these negative health outcomes of inactivity can be counteracted by increasing physical activity levels⁹⁻¹³. Thus, interventions aimed at increasing the physical activity levels of hospitalized patients are of great importance¹⁴.

Many different barriers and enablers influence patients' physical activity behavior¹⁴⁻²⁰. While barriers reduce or negatively affect a patient's physical activity behavior^{15,18,21}, enablers enhance or positively affect this behavior^{14,16,19,20}. Brown et al. have investigated barriers to physical activity in older adults admitted to a medical ward¹⁵. They identified having symptoms (e.g., weakness, pain, fatigue), being concerned about falls, and a lack of staff to assist with out-of-bed physical activity as frequently reported barriers. So et al. also described not being provided with adequate walking aids and being attached to an intravenous line as barriers¹⁴. Moreover, they identified many enablers, such as being encouraged to exercise, preventing the negative effects of prolonged bed rest, and promoting functional recovery.

Over the past two decades, the number of studies identifying barriers or enablers to physical activity during a hospital stay for acute care has grown significantly¹⁴⁻²¹. In these studies, barriers and enablers were identified in a wide variety of patient populations and clinical settings¹⁴⁻²¹. Furthermore, they were explored from the perspective of patients^{14,20}, healthcare professionals (HCPs)^{16-18,21}, or both^{15,19}. To our knowledge, no comprehensive overview of barriers and enablers to physical activity during a hospital stay for acute care has been published. Such a comprehensive overview would provide clinicians and researchers with a better understanding of these barriers and enablers. This might improve the development of future interventions or implementation of existing interventions in different health care settings.

To be able to use such an overview in future intervention development or translation, it is essential to adopt a theoretical framework that links barriers and enablers to intervention strategies. A theoretical framework can help to guide interventions targeting modifiable factors for physical activity during the hospital stay for acute care^{22,23}. Moreover, using a theoretical framework to identify barriers and enablers to behavioral change has been demonstrated to be more successful in changing behavior than using a non-theory-driven approach^{24,25}.

One such integrative theoretical framework is the Theoretical Domains Framework (TDF)²⁵. The TDF facilitates a systematic and theoretically based approach to behavior change. The validated TDF contains 14 domains, comprising 84 theoretical constructs from 33 theories of behavior and behavior change. Barriers and enablers can be categorized in the following domains: *Knowledge, Skills, Social/Professional Role and Identity (SPRI)*, *Beliefs about Capabilities, Optimism, Beliefs about Consequences, Reinforcement, Intentions, Goals, Memory, Attention and Decision Processes (MADP)*, *Environmental Context and Resources (ECR)*, *Social Influences, Emotion*, and *Behavioural Regulation*. The TDF has been extensively used as a guide to identify and categorize modifiable factors that influence behavior²⁵. The objective of this review was to identify and categorize patient- and HCP-reported barriers and enablers to physical activity during a hospital stay for acute care, using the TDF.

METHODS

Study design

A scoping review was performed to explore the nature and quantity of published literature on barriers and enablers to physical activity during a hospital stay for acute care, as perceived by hospitalized patients and their HCPs. We used the scoping review methodology suggested by Arksey and O'Malley²⁶ and developed further by Levac, Colquhoun, and O'Brien^{27,28}. The Joanna Briggs Institute (JBI) guidance document for the conduct of scoping reviews and the Preferred Reporting Items for Systematic Reviews and Meta-Analyses Extension for Scoping Review (PRISMA-ScR) were used to inform the methodology (Additional File 1)^{29,30}. The TDF was used to categorize the barriers and enablers extracted from the included studies²⁵, as described in further detail in "Collating, summarizing, and reporting the results". No protocol was registered for this review.

Search strategy and study selection

A comprehensive search strategy was developed in collaboration with an experienced research librarian (FvE) of the University of Amsterdam (Additional File 2). An electronic database search of MEDLINE (through Pubmed), CINAHL Plus, Cochrane, EMBASE, PsycINFO, and the Cochrane library was performed, from the inception of the electronic databases to September 23, 2020.

All electronic database searches were combined and de-duplicated in Endnote version X9.1 (Clarivate Analytics, Philadelphia, Pennsylvania, USA)³¹. Two reviewers (SJGG and HCVdH) independently screened all titles and abstracts to determine eligibility, based on the following inclusion and exclusion criteria. Studies were

considered eligible if they reported barriers or enablers to physical activity during a hospital stay as perceived by patients or HCPs. Patients had to be hospitalized in an acute care setting and HCPs had to be involved in clinical care (e.g., physicians, nurses, nursing assistants, occupational therapists, and physiotherapists). Barriers were defined as any factor reducing or negatively affecting a patient's engagement in physical activity. Enablers were defined as any factor enhancing or positively affecting a patient's engagement in physical activity. Barriers and enablers had to be self-reported. Studies reporting factors associated or correlated to physical activity during were not included in this study³². Published full-text articles using quantitative, qualitative, or mixed-method study designs were considered, as was gray literature (i.e., academic papers, theses, and dissertations). Only studies written in English or Dutch were included. Studies reporting solely on children (<18 years), short-stay admissions (<24 h), the Intensive Care Unit, or psychiatric ward were excluded because of the differences in care and context (e.g., in terms of organization of care, length of hospital stay, patient characteristics, and care provided). Protocols and reviews were excluded as they lack empirical data. Case studies were also excluded as they often describe extreme cases that do not represent the general population of hospitalized patients. Lastly, conference abstracts were excluded.

To ensure that at least 80% agreement was reached between the reviewers in determining eligibility based on study titles and abstracts, a pilot was performed using 5% of the references. The pilot resulted in minor revisions of the inclusion and exclusion criteria, to enhance the clarity of the criterion descriptors. Full-text articles were obtained when studies fulfilled the criteria or when additional information was needed to determine eligibility. Subsequently, full-text articles were independently screened by both reviewers to determine eligibility. To ensure that at least 80% agreement was reached between reviewers in determining eligibility based on full texts, a pilot was first performed using 10% of the references.

To reduce the risk of missing relevant studies, reference lists of included studies and the reviewers' own literature databases were screened for additional studies. Any disagreements during the study selection process were resolved by discussion, mediated by a senior researcher (AFL). The web application of Rayyan QCRI (Qatar Computing Research Institute, Hamad Bin Khalifa University) was used to facilitate the study selection process.³³ A PRISMA-ScR flowchart was created to track the screening and inclusion process of this review^{30,33}.

Data extraction

Both reviewers (SJGG and HCVDH) independently extracted data using a custom-built data extraction form. Characteristics of included studies (author(s), year of publication, type of study, study aim, method, population, setting, and study

sample) were extracted according to the JBI Guidance document for the conduct of scoping reviews²⁹. Barriers and enablers identified in the results sections of the included studies were extracted using an iterative data extraction process. Barriers and enablers reported by patients and HCPs were extracted separately. Different extraction methods were used for qualitative and quantitative studies³⁴. From qualitative studies, all barriers and enablers reported by patients or HCPs were extracted. For quantitative studies, the approach described by Weatherson³⁵ was used, meaning that barriers and enablers were extracted if $\geq 50\%$ of participants agreed that the factor influenced patients' physical activity behavior. For example, in a survey with dichotomous answering options (agree/disagree), the factor "discussing physical activity during physician rounds increases patients' physical activity levels" was not extracted as an enabler if 42% of the HCPs agreed. Some questionnaire measures contained an intermediate category, such as 5-point Likert-scale questions with answering options: 1=strongly agree, 2=somewhat agree, 3=neither agree nor disagree, 4=somewhat disagree, and 5=strongly disagree. Barriers or enablers were only extracted if at least 50% of participants somewhat agreed or strongly agreed that they perceived it as a barrier or enabler [35]. For example, if 60% of the HCPs agreed (18% somewhat agreed and 42% strongly agreed) that "discussing physical activity during physician rounds increases patients' physical activity levels" was an enabler, this factor was extracted as enabler³⁵. If a quantitative study included open-ended questions, the responses were extracted as in qualitative studies.

To ensure the reliability of the data extraction process, the reviewers first extracted data from five randomly selected articles^{14-16,19,36} and discussed their findings to resolve disagreements and improve the preliminary data extraction table. This process was then repeated with five other articles^{17,21,37-39}, after which both researchers agreed on the data extraction and no further changes to the data extraction table were required. Finally, each reviewer independently extracted half of the remaining articles and then critically reviewed the extraction of the other half performed by the other reviewer. Disagreements were resolved by discussion and rereading source material, and two senior researchers were consulted in case of discrepancies (AFL and MvdS).

Collating, summarizing, and reporting the results

Both reviewers (SJGG and HCvDH) independently coded the extracted barriers and enablers and categorized them into the 14 TDF domains^{25,40,41}. The theoretical definitions and component constructs of the domains as presented in Additional File 3 were used to guide the coding process. Barriers and enablers were coded separately for patients and HCPs and were coded to more than one domain if the content suited multiple domains. To increase inter-coder reliability, the two reviewers (SJGG and HCvDH) met to discuss coding discrepancies and to iteratively

modify the coding structure after every ten articles. Discrepancies were solved by discussion and rereading the articles. If necessary, a senior researcher (MvdS) was consulted to discuss and resolve discrepancies. This process was repeated until a final TDF categorization had been obtained. Two senior researchers (AFL and MvdS) supervised the categorization process. The entire authorship team reviewed the final categorization. MAXQDA Analytics Plus 2020 (VERBI Software, 2018, Berlin, Germany) was used to facilitate data coding and the categorization process. The numbers of different barriers and enablers assigned per TDF domain as well as the number of articles reporting on barriers and enablers per TDF domain were presented separately for patients and HCPs. Finally, a descriptive summary of the reported barriers and enablers was composed for patients and HCPs.

RESULTS

The search retrieved 6716 studies, of which 2382 were excluded as duplicates. An additional three studies⁴²⁻⁴⁴ were retrieved by hand-searching the researchers' own literature database (i.e., two studies which did not explicitly mention "barrier," "enabler," or "hospital" in the title and abstract, and one which was a Masters thesis). A total of 4334 studies were screened based on titles and abstracts. Of the 143 articles that were assessed as full texts, 45 were identified for inclusion^{11,14-16,18-21,36-39,42-74}. An additional 11 studies were included after hand-searching the reference lists of included studies^{17,75-84}, resulting in a total of 56 included studies^{11,14-21,36-39,42-84}. The PRISMA-ScR flowchart (Figure 2.1) shows the screening and inclusion process.

Description of included studies

Additional File 4 presents an overview of the included studies. Of the 56 studies, 32 used a qualitative study design^{14-20,38,42,44-46,49-54,57,61,67,68,70,72-76,78-80,83}, seven a quantitative study design^{21,37,39,63,66,69,82}, and 17 a mixed-methods study design^{11,36,43,47,48,55,56,58-60,62,64,65,71,77,81,84}. Nineteen studies reported barriers and enablers as perceived by patients^{14,20,36,37,39,48,51,61,63-65,67,70,73,78,79,81,83}, 23 reported those perceived by HCPs^{16-18,21,38,42,43,47,50,52-55,57,59,60,68,69,74-76,80,82}, and 14 reported those perceived by patients and HCPs^{11,15,19,44-46,49,56,58,62,66,71,72,77,84}. Sample sizes varied between $n=6$ and $n=345$ patients and between $n=5$ and $n=261$ HCPs. Two studies did not specify the sample size^{11,77}, and one study only specified the number of included sites⁴⁷. Further descriptions of the populations and settings included are provided in Additional File 4. The included studies were published between 2003 and 2020, and only seven studies were published before 2010^{15,52,56,75,77,78,82}.

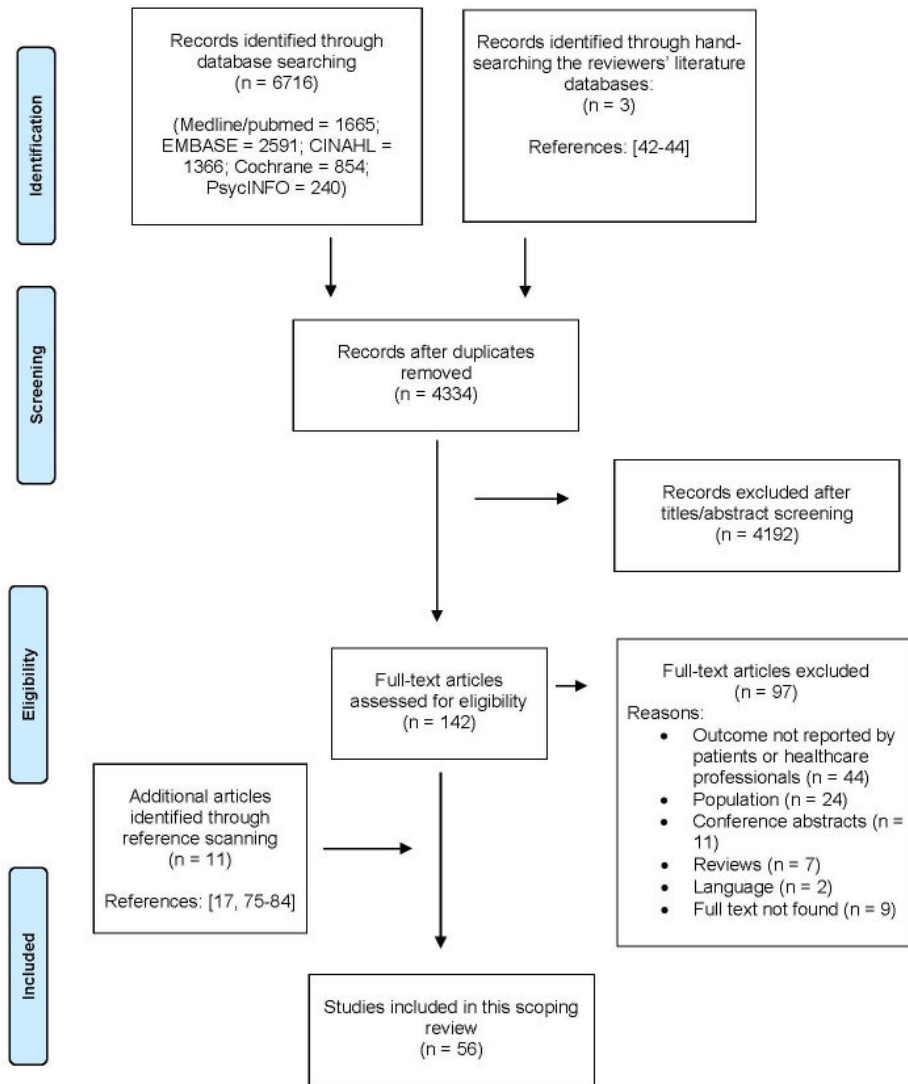

Figure 2.1 PRISMA-ScR flowchart

Identification of patient- and HCP-reported barriers and enablers to physical activity during a hospital stay for acute care

The results of the data extraction process are presented in Additional File 5. After coding and discussing all extracted fragments containing barriers and enablers, SJGG and HCvDH reached a consensus on 1316 barriers and enablers. Two hundred

sixty-four (20.2%) patient-reported barriers and 415 (31.7%) HCP-reported barriers were coded. Two hundred twenty-eight (17.3%) patient-reported enablers and 409 (31.2%) HCP-reported enablers were coded.

Categorizing patient- and HCP-reported barriers using the TDF

Patient- and HCP-reported barriers were assigned to 13 of the 14 TDF domains. An overview of the TDF coding of all barriers is provided in Additional File 6 and summarized in Figure 2.2. Patient-reported barriers were assigned most frequently to the TDF domains *ECR* ($n=148$, 56.1%), *Social Influences* ($n=32$, 12.1%), and *Beliefs about Consequences* ($n=25$, 9.5%). Of the other 11 domains, the largest numbers of barriers were assigned to the domains *Emotion* ($n=16$, 6.1%) and *SPRI* ($n=10$, 3.8%). HCP-reported barriers were assigned most frequently to the TDF domains *ECR* ($n=210$, 50.6%), *MADP* ($n=45$, 10.8%), and *SPRI* ($n=31$, 7.5%). Of the other 11 domains, the largest numbers of barriers were assigned to the domains *Beliefs about Consequences* ($n=27$, 6.5%) and *Emotion* ($n=22$, 5.3%). No patient- and HCP-reported barriers were assigned to the domain *Optimism*.

The TDF domains to which barriers were most frequently assigned are highlighted below. The domain *ECR* had the majority of both patient- and HCP-reported barriers assigned to it and covered four main topics: (1) patient-related factors (e.g., medical factors, age, language barriers), (2) care processes and organizational characteristics (e.g., prescribed immobility, communication, hospital culture, bed-centered care), (3) physical environment of the hospital (e.g., room, unit, hospital), and (4) resources (e.g., limited time, staffing, equipment) (Additional File 6). Patient-reported barriers assigned to the domain *Social Influences* included interpersonal processes between patients, visitors, and HCPs that negatively influence physical activity, such as lack of encouragement and assistance and providing more care than necessary. Patient-reported barriers assigned to the domain *Beliefs about Consequences* included the belief that physical activity results in negative consequences (e.g., injuries, falling, or missing meals and care), the belief that rest is needed for recovery, and the belief that patients may be inconveniencing busy HCPs. Most of the HCP-reported barriers assigned to the domain *MADP* related to prioritization. A high workload and safety considerations resulted in physical activity receiving a lower priority than medical treatment or rest. HCP-reported barriers assigned to the domain *SPRI* included the passive and dependent attitude patients adopt during hospitalization (e.g., the idea that patients should remain in bed, personality, and character traits). In addition, HCPs mentioned the role they fulfill regarding physical activity (e.g., lack of role clarity in improving physical activity, attributing responsibility to others, and nurses lacking autonomy in deciding how and when to mobilize patients).

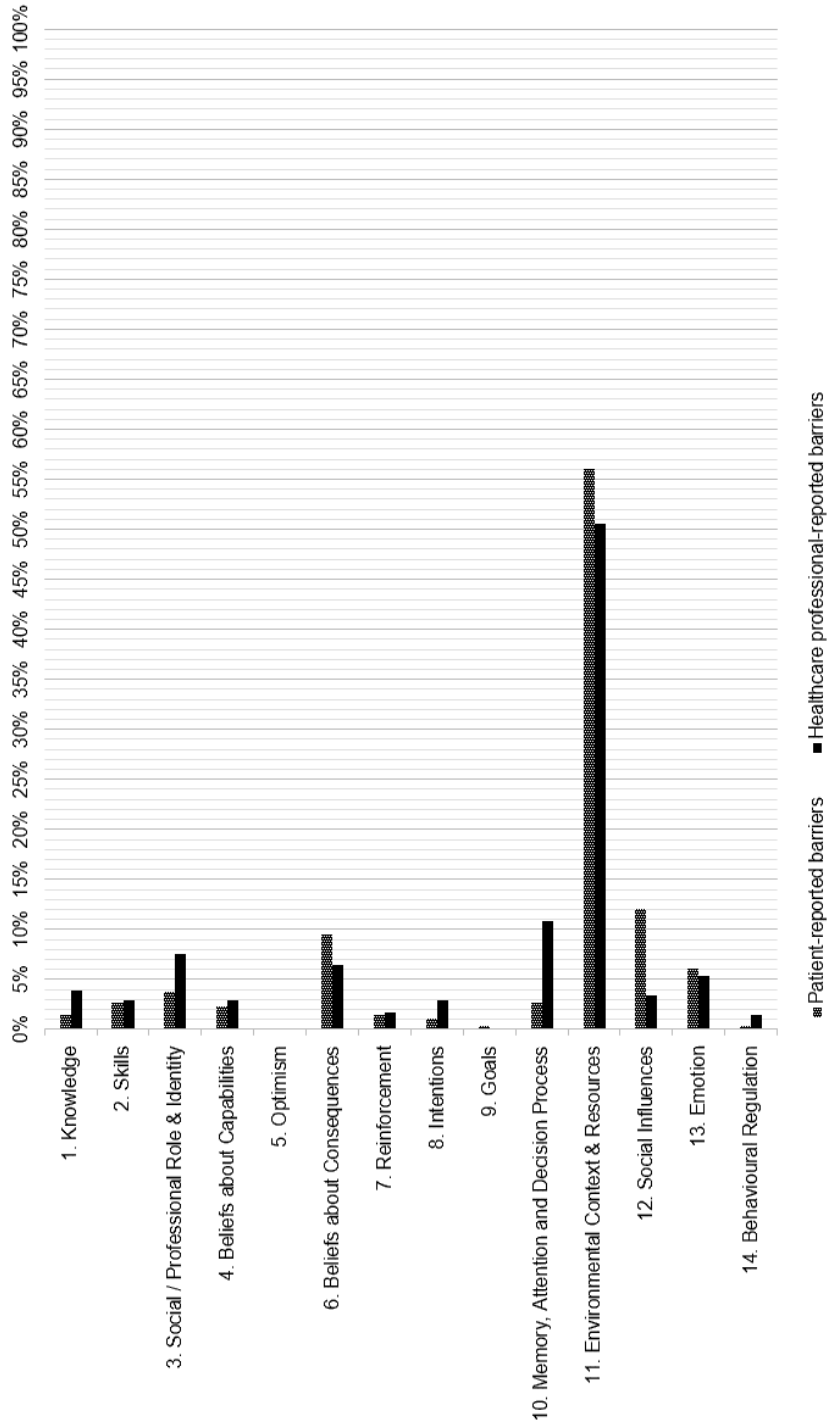

Figure 2.2 Barriers assigned to each domain of the Theoretical Domains Framework (% of total number of reported barriers).

Categorizing patient- and HCP-reported enablers using the TDF

Patient- and HCP-reported enablers were assigned to 11 and 13 of the 14 TDF domains, respectively. An overview of the TDF-coding of all enablers is provided in Additional File 7 and summarized in Figure 2.3. Patient-reported enablers were most frequently assigned to the TDF domains *ECR* ($n=67$, 30.2%), *Social Influences* ($n=54$, 24.3%), and *Goals* ($n=32$, 14.4%). Of the remaining 11 domains, the largest numbers of enablers were assigned to the domains *Knowledge* ($n=24$, 10.5%) and *Beliefs about Consequences* ($n=17$, 7.7%). No patient-reported enablers were assigned to the domains *Reinforcement*, *MADP*, and *Emotion*. HCP-reported enablers were most frequently assigned to the TDF domains *ECR* ($n=143$, 35.0%), *Social Influences* ($n=76$, 18.6%), and *Behavioral Regulation* ($n=54$, 13.2%). Of the remaining 11 domains, the largest numbers of enablers were assigned to the domains *SPRI* ($n=45$, 11%) and *Knowledge* ($n=19$, 4.7%). No HCP-reported enablers were assigned to the domain *Optimism*.

In line with the categorization of the barriers, most patient- and HCP-reported enablers were assigned to the domain *ECR* and covered the same four main topics: (1) patient-related factors, (2) care processes and organizational characteristics, (3) physical environment of the hospital, and (4) resources (Additional File 7). Patient- and HCP-reported enablers assigned to the domain *Social Influences* included interpersonal processes between patients and visitors or HCPs that positively influence physical activity, such as being encouraged and assisted. Patients also described that other patients motivated them to perform more physical activity, while HCPs described how leadership and multidisciplinary collaboration enabled them to improve patients' physical activity. Patient-reported enablers assigned to the domain *Goals* included the importance of having a goal (e.g., experiencing the positive effects of physical activity or preventing the negative effects of physical inactivity). This domain also included the importance of having autonomy and being involved in physical activity-related decision-making. HCP-reported enablers assigned to the domain *Behavioural Regulation* included strategies aimed at regulating behavior, such as providing education, appointing mobility champions, making performance and expectations visible, creating a habit, and using mobility documentation tools, reminders, daily schedules, exercise programs, and mobility audits.

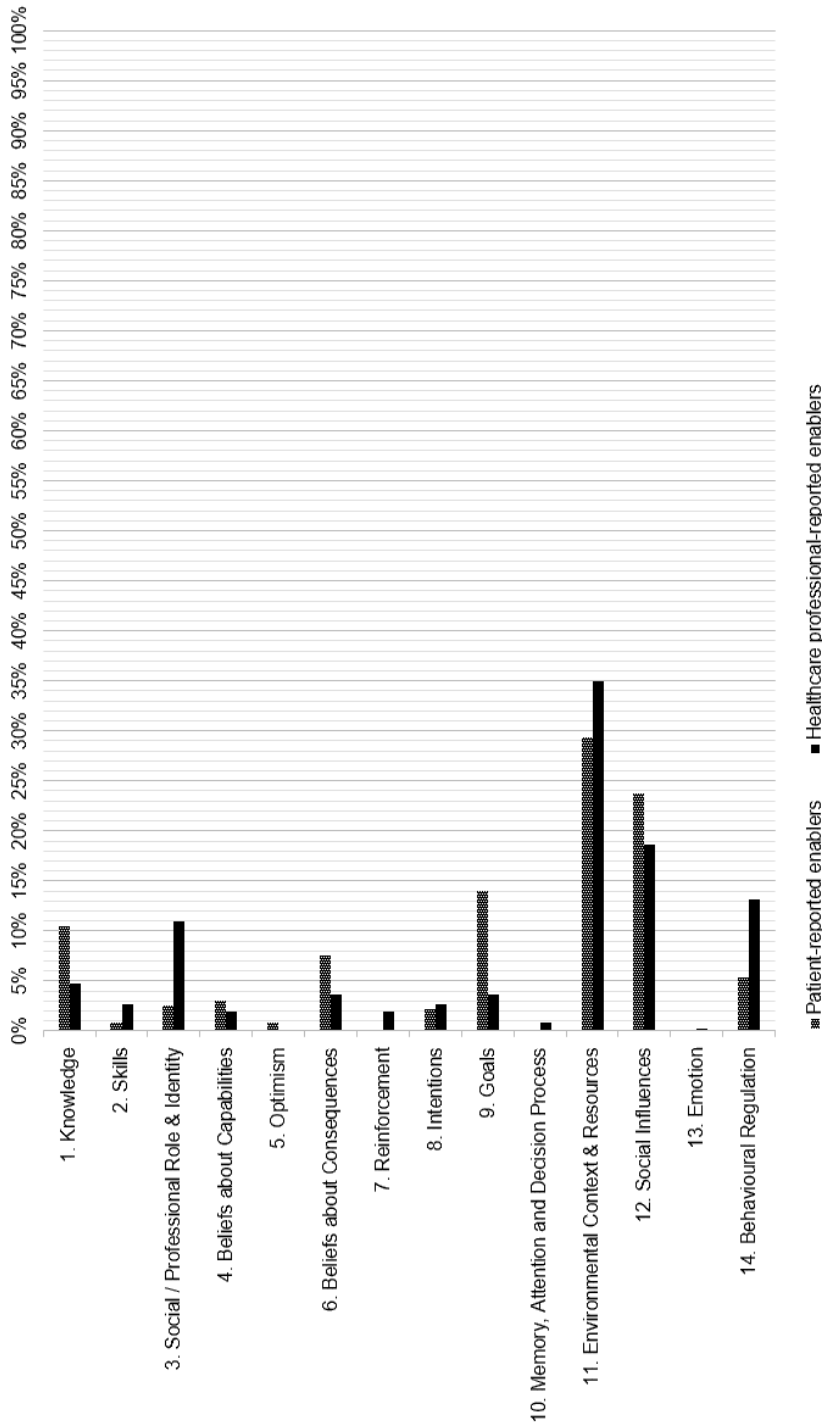

Figure 2.3 Enablers assigned to each domain of the Theoretical Domains Framework (% of total number of reported enablers)

DISCUSSION

The aim of this study was to identify and categorize patient- and HCP-reported barriers and enablers to physical activity during a hospital stay for acute care, using the TDF. Our systematic search identified 679 barriers and 637 enablers, reported in 56 studies. The majority of barriers and enablers were assigned to the key domain *Environmental Context and Resources* (i.e., “patient-related factors,” “care processes and organizational characteristics,” “physical environment of the hospital,” and “resources”). Other key TDF domains to which the largest numbers of barriers were assigned were *Social Influences*, *Beliefs about Consequences*, *Memory*, *Attention and Decision Process*, and *Social/Professional Role & Identity*. Additionally, other key domains to which the largest numbers of enablers were assigned were *Social Influences*, *Goals*, and *Behavioural Regulation*. This is the first scoping review of patient- and HCP-reported barriers and enablers relating to physical activity during the hospital stay for acute care using a TDF analysis. This review presents a comprehensive overview of these barriers and enablers from a theoretical perspective, which can help clinicians and researchers identify and target modifiable factors within future intervention development.

Our findings highlight the prominent role of the domain *Environmental Context and Resources* with respect to physical activity during the hospital stay for acute care. Upon hospital admission, patients are taken out of their own environment and enter a different, unfamiliar context, filled with many uncertainties. In addition to patients’ illness and associated medical factors, the hospital environment exerts an inactivating influence on patients, resulting in a loss of autonomy and freedom^{15,44}. Our findings indicate that “care processes and organizational characteristics,” the “physical environment,” “patient-related factors,” and “resources” are the main topics of the domain *Environmental Context and Resources* that influence the physical activity behavior of hospitalized patients. Several studies have aimed to improve physical activity in hospitalized patients by targeting these main environmental factors^{11,12,71,85}. “Care processes and organizational characteristics” was targeted by incorporating physical activity in usual care^{12,85,86}, creating policy to promote mobility⁷¹, incorporating specific timeslots for physical activity in HCPs’ schedules⁷¹, improving communication¹², and providing patients with graded exercise programs¹¹. “Physical environment” was targeted by providing interesting walking destinations¹¹, marked walking trails⁷¹, distance markers in the hallway⁷¹, ward maps and signs¹¹, and by making mobilization goals visible^{12,86}. “Patient-related factors” were targeted by optimizing pain control¹², and “resources” by purchasing more walking aids⁷¹, supporting physical activity with technology^{86,87}, and supplying activity diaries and exercise booklets^{11,85}.

Our results also highlight the role of the domain *Social Influences*, identified as the second most prominent TDF domain. The absence of encouragement and assistance by others (i.e., nurses, physical therapists, physicians, visitors, volunteers, or other patients) was identified as an important barrier by patients, whereas their presence as an important enabler. This was substantiated by HCPs, who also added multidisciplinary teamwork, leadership support, the presence of physical therapists, and involving visitors as important enablers of physical activity. Several studies have aimed to improve physical activity by targeting the domain *Social Influences*, by providing systematic encouragement and assistance from HCPs^{11,71,85,86}, involving volunteers or family members in basic mobility activities^{11,86}, and encouraging independence in activities of daily living¹¹.

Moreover, the domains *Beliefs about Consequences*, *Memory, Attention and Decision Process*, and *Social/Professional Role & Identity* also contained many barriers. Several studies have targeted these domains to improve patients' physical activity levels, such as providing education to counter the belief that physical activity will result in injuries^{86,88}, using shift huddles to address prioritizing physical activity⁸⁹, or mapping the therapy consultation process within a multidisciplinary team to create role clarity and avoid unnecessary treatments⁹⁰. Likewise, the domains *Goals* and *Behavioural Regulation* contained many enablers. Examples of interventions that specifically focus on goal setting and behavioral regulation are the Johns Hopkins Highest Level of Mobility tool¹², the WALK-FOR 900 steps per day behavioral target⁹¹, and Hospital Fit monitor⁸⁷. All these interventions enable monitoring physical activity levels and setting physical activity goals in daily clinical care.

Our findings indicated that there were several TDF domains (e.g., *Skills, Optimism, Reinforcement*) to which few or no barriers and enablers were assigned. The many factors assigned to the TDF domains *Environmental Context and Resources* and *Social Influences*, and the few factors assigned to the domains *Skills, Optimism*, and *Reinforcement* are in agreement with the results of similar research performed in other populations, such as physical activity at school³⁵, work⁹², or in primary care⁹³. Although this highlights the prominent role of the domains *Environmental Context and Resources* and *Social Influences* on physical activity behavior, it does not indicate whether the domains *Skills, Optimism*, and *Reinforcement* do not contain relevant barriers and enablers to physical activity, or whether they were under-identified.

Lastly, although many patient-reported barriers and enablers were also reported by HCPs, our results demonstrated that HCPs perceived a greater number of barriers and enablers than patients. This could be explained by the different perspectives of patients and HCPs on physical activity during the hospital stay.

Patients are hospitalized for a relatively short period, with their main focus being their illness and getting better. They experience how it feels to be a patient and how this influences their physical activity behavior. On the other hand, HCPs perceive barriers and enablers from a much broader perspective. Firstly, they report barriers and enablers from their own as well as their patients' perspectives. Secondly, they provide care to many patients with different pathologies, ages, and backgrounds. Thirdly, they perceive barriers and enablers related to providing care, different care processes, and organizational characteristics. These differences in perspectives between patients and HCPs emphasize that both must be taken into account to gain a comprehensive understanding of the barriers and enablers to physical activity during a hospital stay.

Strengths and limitations

This is the first scoping review on patient- and HCP-reported barriers and enablers relating to physical activity during the hospital stay for acute care using a TDF analysis. A strength of this study is that it was designed and conducted according to the systematic scoping review methodology and that it followed the PRISMA-ScR statement recommendations²⁶⁻³⁰. Secondly, almost all aspects of data collection, data extraction, and data analysis were carried out independently by two researchers, with a third party available in case of disagreements. Thirdly, given the extensive, thorough search strategy in multiple databases, along with the inclusion of quantitative, qualitative as well as mixed-methods study designs, we were able to present a complete overview of all barriers and enablers reported in the current literature. Fourthly, an additional strength of this study is the use of the TDF as a theoretical framework to categorize barriers and enablers. The use of the TDF ensured that the reviewers assessed barriers and enablers from a broad perspective, thereby also exploring underexposed domains.

We also recognize some limitations. While the use of the TDF facilitates reviewers in exploring barriers and enablers from a broad perspective, it does not provide an explanation as to how barriers and enablers are connected and influence one another. Another limitation of this study is that barriers and enablers are presented based on the number of articles in which they have been reported. As the frequency of reporting is primarily a function of the methods used to present the data, this alone should not be used as a proxy of importance. In other words, a barrier that has only been reported once may be just as relevant as one that has been reported many times. Furthermore, a secondary analysis of differences in perceived barriers and enablers among patient subgroups or among professions could not be performed due to the lack of detailed reporting in the included studies. Lastly, as this was a scoping review, no quality appraisal of included articles was performed³⁰.

Clinical implications and recommendations for future research

Our findings provide a comprehensive overview of barriers and enablers to physical activity during a hospital stay for acute care. The large number of barriers and enablers we found, distributed across many TDF domains, highlight the complexity of physical activity behavior during the hospital stay and the need for tailored interventions. A context-based assessment should be performed to determine which barriers and enablers can be targeted in a specific clinical setting. Our comprehensive overview will enable clinicians and researchers to perform this context-based assessment from a broad perspective and support them in establishing a behavioral diagnosis of what needs to change in a specific context in order to improve physical activity behavior during the hospital stay.

Subsequently, clinicians and researchers will be able to link relevant barriers and enablers to specific intervention strategies and behavior change techniques (BCTs)^{25,41,94}. An example of a framework that could be used to assist clinicians and researchers in selecting appropriate BCTs is the Behaviour Change Wheel (BCW)²². Our TDF-based overview provides the initial step in developing and implementing theory-informed behavior change interventions aimed at improving physical activity during the hospital stay⁴¹.

Given the large number of factors influencing the physical activity behavior of hospitalized patients, we recommend that clinicians and researchers develop and implement interventions targeted at multiple barriers and enablers. Previous research suggests that developing and implementing such tailored multimodal interventions may be more effective than unimodal interventions⁹⁵. Moreover, given a large number of barriers and enablers assigned to the *Environmental Context and Resources* and *Social Influences* context in our review, we suggest that clinicians and researchers should always consider incorporating intervention strategies targeting these TDF domains in their multimodal interventions.

Future research should focus on exploring relationships between barriers and enablers both within and between TDF domains. Revealing these relationships may facilitate the assessment of barriers and enablers in specific clinical settings and may increase the effectivity of future tailored multimodal interventions. Future research is also needed to explore the differences in perspectives perceived by different patient subgroups (e.g., age, sex, pathologies). Similarly, more research is needed to investigate differences in perceived barriers and enablers among professions and how these differences relate to their role in improving physical activity during the hospital stay. Additionally, further research is needed to develop and validate a TDF-based questionnaire that could facilitate the context-based assessment of barriers and enablers across all TDF domains. Further research is needed to retrospectively identify which barriers and enablers to physical activity

during the a hospital stay have been targeted in previously described intervention studies⁹⁴, so clinicians may be better able to implement these interventions in other contexts. Finally, there is a need for research assessing the effectiveness of tailored multimodal interventions that target context-based barriers and enablers to physical activity in hospitalized patients.

CONCLUSIONS

This article presents a comprehensive overview of 1316 patient- and HCP-reported barriers and enablers to physical activity during a hospital stay for acute care. A large number of barriers and enablers found highlight the complexity of physical activity behavior during the hospital stay. Our overview can assist clinicians and researchers in performing a context-based assessment to determine which barriers and enablers to target in future interventions. Given the large number of factors influencing the physical activity behavior of hospitalized patients, we recommend developing and implementing multimodal interventions. This scoping review also highlights the large role of environmental and social factors on physical activity behavior during the hospital stay and suggests that intervention strategies targeting these domains should be incorporated. Future research should focus on exploring the relationships between barriers and enablers both within and between different TDF domains. Revealing these relationships may facilitate the assessment of barriers and enablers in specific clinical settings and may increase the effectivity of future tailored multimodal interventions. Furthermore, future research is also needed to explore the differences in perspectives perceived among different patient subgroups or different professions. Lastly, a validated TDF-based questionnaire is needed to facilitate future context-based assessments of barriers and enablers, and further research should investigate the effectiveness of tailored multimodal interventions.

SUPPLEMENTARY INFORMATION

Additional File 1 to 7 can be found online: <https://doi.org/10.1186/s13643-021-01843-x>

ACKNOWLEDGEMENTS

We would like to thank the research librarian Faridi van Etten for her assistance with the search strategies and the de-duplication of all titles and abstracts. We would also like to thank Jan Klerkx who provided language editing services.

REFERENCES

1. Fazio S, Stocking J, Kuhn B, Doroy A, Blackmon E, Young HM, et al. How much do hospitalized adults move? A systematic review and meta-analysis. *Appl Nurs Res.* 2019;51:151189.
2. Buurman BM, Hoogerduijn JG, de Haan RJ, Abu-Hanna A, Lagaay AM, Verhaar HJ, et al. Geriatric conditions in acutely hospitalized older patients: prevalence and one-year survival and functional decline. *PLoS One.* 2011;6(11):e26951.
3. Boyd CM, Landefeld CS, Counsell SR, Palmer RM, Fortinsky RH, Kresevic D, et al. Recovery of activities of daily living in older adults after hospitalization for acute medical illness. *J Am Geriatr Soc.* 2008;56(12):2171-9.
4. Brown CJ, Friedkin RJ, Inouye SK. Prevalence and outcomes of low mobility in hospitalized older patients. *J Am Geriatr Soc.* 2004;52(8):1263-70.
5. Mahoney JE, Sager MA, Jalaluddin M. New walking dependence associated with hospitalization for acute medical illness: incidence and significance. *J Gerontol A Biol Sci Med Sci.* 1998;53(4):M307-12.
6. Brown CJ, Redden DT, Flood KL, Allman RM. The underrecognized epidemic of low mobility during hospitalization of older adults. *J Am Geriatr Soc.* 2009;57:1660-5.
7. Covinsky KE, Palmer RM, Fortinsky RH, Counsell SR, Stewart AL, Kresevic D, et al. Loss of independence in activities of daily living in older adults hospitalized with medical illnesses: increased vulnerability with age. *J Am Geriatr Soc.* 2003;51:451-8.
8. Ostir GV, Berges IM, Kuo YF, Goodwin JS, Fisher SR, Guralnik JM. Mobility activity and its value as a prognostic indicator of survival in hospitalized older adults. *J Am Geriatr Soc.* 2013;61(4):551-7.
9. Agmon M, Zisberg A, Gil E, Rand D, Gur-Yaish N, Azriel M. Association between 900 steps a day and functional decline in older hospitalized patients. *JAMA Intern Med.* 2017;177(2):272-4.
10. Brown CJ, Foley KT, Lowman JD Jr, MacLennan PA, Razjouyan J, Najafi B, et al. Comparison of posthospitalization function and community mobility in hospital mobility program and usual care patients: a randomized clinical trial. *JAMA Intern Med.* 2016;176(7):921-7.
11. Mudge AM, McRae P, Cruickshank M. Eat walk engage: an interdisciplinary collaborative model to improve care of hospitalized elders. *Am J Med Qual.* 2015;30(1):5-13.
12. Hoyer EH, Friedman M, Lavezza A, Wagner-Kosmakos K, Lewis-Cherry R, Skolnik JL, et al. Promoting mobility and reducing length of stay in hospitalized general medicine patients: a quality-improvement project. *J Hosp Med.* 2016;11(5):341-7.
13. Stolbrink M, McGowan L, Saman H, Nguyen T, Knightly R, Sharpe J, et al. The early mobility bundle: a simple enhancement of therapy which may reduce incidence of hospital-acquired pneumonia and length of hospital stay. *J Hosp Infect.* 2014;88:34-9.
14. So C, Pierluissi E. Attitudes and expectations regarding exercise in the hospital of hospitalized older adults: a qualitative study. *J Am Geriatr Soc.* 2012;60(4):713-8.
15. Brown CJ, Williams BR, Woodby LL, Davis LL, Allman RM. Barriers to mobility during hospitalization from the perspectives of older patients and their nurses and physicians. *J Hosp Med.* 2007;2:305-13.
16. Boltz M, Capezuti E, Shabbat N. Nursing staff perceptions of physical function in hospitalized older adults. *Appl Nurs Res.* 2011;24(4):215-22.
17. Doherty-King B, Bowers B. How nurses decide to ambulate hospitalized older adults: development of a conceptual model. *Gerontologist.* 2011;51:786-97.
18. Moore JE, Mascarenhas A, Marquez C, Almaawiy U, Chan WH, D'Souza J, et al. Mapping barriers and intervention activities to behaviour change theory for Mobilization of Vulnerable Elders in Ontario (MOVE ON), a multi-site implementation intervention in acute care hospitals. *Implement Sci.* 2014;9:160.
19. De Klein K, Valkenet K, Veenhof C. Perspectives of patients and healthcare professionals on physical activity of hospitalized patients. *Physiother Theory Pract.* 2021;37(2):307-14.
20. Boltz M, Capezuti E, Shabbat N, Hall K. Going home better not worse: older adults' views on physical function during hospitalization. *Int J Nurs Pract.* 2010;16(4):381-8.
21. Hoyer EH, Brotman DJ, Chan KS, Needham DM. Barriers to early mobility of hospitalized general medicine patients: survey development and results. *Am J Phys Med Rehabil.* 2015;94(4):304-12.
22. Michie S, Atkins L, West R. *The behaviour change wheel: a guide to designing interventions.* 1st ed. United Kingdom: Silverback Publishing; 2014. 647978-1-291-84605-8
23. Nilsen P. Making sense of implementation theories, models and frameworks. *Implement Sci.* 2015;10(1):53.

24. Gourlan M, Bernard P, Bortolon C, Romain AJ, Lareyre O, Carayol M, et al. Efficacy of theory-based interventions to promote physical activity. A meta-analysis of randomised controlled trials. *Health Psychol Rev.* 2016;10(1):50-66.
25. Atkins L, Francis J, Islam R, O'Connor D, Patey A, Ivers N, et al. A guide to using the Theoretical Domains Framework of behaviour change to investigate implementation problems. *Implement Sci.* 2017;12(1):77.
26. Arksey H, O'Malley L. Scoping studies: towards a methodological framework. *Int J Soc Res Methodol.* 2005;8(1):19-32.
27. Colquhoun HL, Levac D, O'Brien KK, Straus S, Tricco AC, Perrier L, et al. Scoping reviews: time for clarity in definition, methods, and reporting. *J Clin Epidemiol.* 2014;67(12):1291-4.
28. Levac D, Colquhoun H, O'Brien KK. Scoping studies: advancing the methodology. *Implement Sci.* 2010;5:69.
29. Peters MDJ, Godfrey C, McInerney P, Baldini Soares C, Khalil H, Parker D. Chapter 11: Scoping reviews. In: Aromataris E, Munn Z, editors. *Joanna Briggs Institute reviewer's manual.* <https://reviewersmanual.joannabriggs.org/> 2017. Accessed 12 Dec 2019.
30. Tricco AC, Lillie E, Zarin W, O'Brien KK, Colquhoun H, Levac D, et al. PRISMA Extension for Scoping Reviews (PRISMA-ScR): checklist and explanation. *Ann Intern Med.* 2018;169(7):467-73.
31. Bramer WM, Giustini D, de Jonge GB, Holland L, Bekhuis T. De-duplication of database search results for systematic reviews in EndNote. *J Med Libr Assoc.* 2016;104(3):240-3.
32. Glowacki K, Duncan MJ, Gainforth H, Faulkner G. Barriers and facilitators to physical activity and exercise among adults with depression: a scoping review. *Ment Health Phys Act.* 2017;13:108-19.
33. Ouzzani M, Hammady H, Fedorowicz Z, Elmagarmid A. Rayyan-a web and mobile app for systematic reviews. *Syst Rev.* 2016;5(1):210.
34. Istanbulian L, Rose L, Gorospe F, Yunusova Y, Dale CM. Barriers to and facilitators for the use of augmentative and alternative communication and voice restorative strategies for adults with an advanced airway in the intensive care unit: a scoping review. *J Crit Care.* 2020;57:168-76.
35. Weatherson KA, Gainforth HL, Jung ME. A theoretical analysis of the barriers and facilitators to the implementation of school-based physical activity policies in Canada: a mixed methods scoping review. *Implement Sci.* 2017;12(1):41.
36. Jahn P, Lakowa N, Landenberger M, Vordermark D, Stoll O. InterACTIV: an exploratory study of the use of a game console to promote physical activation of hospitalized adult patients with cancer. *Oncol Nurs Forum.* 2012;39(2):E84-90.
37. Haines KJ, Skinner EH, Berney S, Austin Health PSI. Association of postoperative pulmonary complications with delayed mobilisation following major abdominal surgery: an observational cohort study. *Physiotherapy.* 2013;99(2):119-25.
38. Kanaskie ML, Snyder C. Nurses and nursing assistants decision-making regarding use of safe patient handling and mobility technology: a qualitative study. *Appl Nurs Res.* 2018;39:141-7.
39. Jonsson LR, Ingelsrud LH, Tengberg LT, Bandholm T, Foss NB, Kristensen MT. Physical performance following acute high-risk abdominal surgery: a prospective cohort study. *Can J Surg.* 2017;60(6):12616.
40. DeCuir-Gunby JT, Marshall PL, McCulloch AW. Developing and using a codebook for the analysis of interview data: an example from a professional development research project. *Field Methods.* 2011;23(2):136-55.
41. Cane J, O'Connor D, Michie S. Validation of the theoretical domains framework for use in behaviour change and implementation research. *Implement Sci.* 2012;7:37.
42. Granger CL, Parry SM, Denehy L, Remedios L. Evidence, education and multi-disciplinary integration are needed to embed exercise into lung cancer clinical care: a qualitative study involving physiotherapists. *Physiother Theory Pract.* 2018;34(11):852-60.
43. van Eijck SAH. Barriers and facilitators to implement function-focused care in hospitals: a mixed methods study: Faculty of Medicine Theses. Utrecht: Utrecht University; 2016.
44. Koenders N, van Oorsouw R, Seeger JPH, Nijhuis-van der Sanden MWG, van de Glind I, Hoogeboom TJ. "I'm not going to walk, just for the sake of walking...": a qualitative, phenomenological study on physical activity during hospital stay. *Disabil Rehabil.* 2020;42(1):78-85.
45. Alawadi ZM, Leal I, Phatak UR, Flores-Gonzalez JR, Holihan JL, Karanjawala BE, et al. Facilitators and barriers of implementing enhanced recovery in colorectal surgery at a safety net hospital: a provider and patient perspective. *Surgery.* 2016;159(3):700-12.

46. Andreassen J, Soendergaard LN, Holst M. Factors affecting patient and nursing staff adherence to an integrated physical activity and nutritional intervention targeting functional decline on an acute medical ward: a qualitative study. *Patient Prefer Adherence*. 2018;12:1425-35.
47. Babine RL, Hyrkas KE, McKenzie CG, Wierman HR. Mobilizing older adults: a multi-site, exploratory and observational study on patients enrolled in the Hospital Elder Life Program (HELP). *Geriatr Nurs*. 2019;40(3):239-45.
48. Boltz M, Resnick B, Capezuti E, Shuluk J. Activity restriction vs. self-direction: hospitalised older adults' response to fear of falling. *Int J Older People Nurs*. 2014;9(1):44-53.
49. Bradley G, Baker K, Bailey C. The meaning of rehabilitation: a qualitative study exploring perspectives of occupational therapists and physiotherapists working with older people in acute care. *Disabil Rehabil*. 2021;43(16):2295-303.
50. Chan E-Y, Hong LI, Tan Y-HG, Chua W-L. Older patients' participation in physical activity during hospitalization: a qualitative study of ward nurses' perceptions in an Asian context. *Geriatr Nurs*. 2019;40:91-8.
51. Clarke C, Stack C, Martin M. Lack of meaningful activity on acute physical hospital wards: older people's experiences. *Br J Occup Ther*. 2017;81:030802261773504.
52. Cook D, Tkaczyk A, Lutz K, McMullin J, Haynes RB, Douketis J. Thromboprophylaxis for hospitalized medical patients: a multicenter qualitative study. *J Hosp Med*. 2009;4(5):269-75.
53. Dahlke SA, Phinney A, Hall WA, Rodney P, Baumbusch J. Orchestrating care: nursing practice with hospitalised older adults. *Int J Older People Nurs*. 2015;10(4):252-62.
54. Dermody G, Kovach CR. Nurses' experience with and perception of barriers to promoting mobility in hospitalized older adults: a descriptive study. *J Gerontol Nurs*. 2017;43(11):22-9.
55. Eastham AJ, Cox D. Dementia-friendly wards: a review of the literature and pilot study of patient interaction and daily activity engagement. *Int J Health Govern*. 2017;22(1):25-36.
56. Gordge L, De Young J, Wiechula R. Reducing functional decline of older people in an acute-care setting: are we providing adequate care to maintain/optimize the functional status of our elder patients? *Int J Evid Based Healthc*. 2009;7(3):181-6.
57. Graf CL. Patient, Nurse, and Hospital Factors That Influence the Mobility of Hospitalized Older Adults. UCSF. ProQuest ID: Graf_ucsf_0034D_10751. REDACTED. Merritt ID: ark:/13030/m5xh1562. San Francisco; 2013. Retrieved from <https://escholarship.org/uc/item/90z7x3tk>.
58. Juneau A, Bolduc A, Nguyen P, Leclerc BS, Rousseau J, Dube F, et al. Feasibility of implementing an exercise program in a geriatric assessment unit: the SPRINT program. *Can Geriatr J*. 2018;21(3):284-9.
59. King BJ, Steege LM, Winsor K, VanDenbergh S, Brown CJ. Getting patients walking: a pilot study of mobilizing older adult patients via a nurse-driven intervention. *J Am Geriatr Soc*. 2016;64(10):2088-94.
60. Kouchel D. Early mobility in hospitalized older adults: needs assessment, analysis and proposed intervention [Masters Thesis]. Carolina: University of North Carolina at Chapel Hill Graduate School; 2017.
61. Leak Bryant A, Walton AL, Pergolotti M, Phillips B, Bailey C, Mayer DK, et al. Perceived benefits and barriers to exercise for recently treated adults with acute leukemia. *Oncol Nurs Forum*. 2017;44(4):413-20.
62. Lim S, Ibrahim K, Dodds R, Purkis A, Baxter M, Rogers A, et al. Physical activity in hospitalised older people: the feasibility and acceptability of a volunteer-led mobility intervention in the SoMoVe™ study. *Age Ageing*. 2019;49(2):283-91.
63. Meesters J, Conijn D, Vermeulen HM, Vliet Vlieland T. Physical activity during hospitalization: activities and preferences of adults versus older adults. *Physiother Theory Pract*. 2019;35(10):975-85.
64. Moreno NA, de Aquino BG, Garcia IF, Tavares LS, Costa LF, Giacomassi IWS, et al. Physiotherapist advice to older inpatients about the importance of staying physically active during hospitalisation reduces sedentary time, increases daily steps and preserves mobility: a randomised trial. *J Physiother*. 2019;65(4):208-14.
65. Murphy JNF, Le Jeune I. Can an acute admission to hospital be an opportunity for healthcare professionals to provide physical activity advice? A qualitative study of patients' perspectives. *Acute Med*. 2018;17(1):10-7.
66. Nesbitt JC, Deppen S, Corcoran R, Cogdill S, Huckabay S, McKnight D, et al. Postoperative ambulation in thoracic surgery patients: standard versus modern ambulation methods. *Nurs Crit Care*. 2012;17(3):130-7.

67. Persson E, Anderberg P, Ekwall AK. A room of one's own--being cared for in a hospital with a single-bed room design. *Scand J Caring Sci.* 2015;29(2):340-6.
68. Rosbergen ICM, Brauer SG, Fitzhenry S, Grimley RS, Hayward KS. Qualitative investigation of the perceptions and experiences of nursing and allied health professionals involved in the implementation of an enriched environment in an Australian acute stroke unit. *BMJ Open.* 2017;7(12):e018226.
69. Sepulveda-Pacsi AL, Soderman M, Kertesz L. Nurses' perceptions of their knowledge and barriers to ambulating hospitalized patients in acute settings. *Appl Nurs Res.* 2016;32:117-21.
70. Tang CY, Taylor NF, Blackstock FC. Patients admitted with an acute exacerbation of chronic obstructive pulmonary disease had positive experiences exercising from the beginning of their hospital stay: a qualitative analysis. *Chron Respir Dis.* 2013;10(4):197-205.
71. Zisberg A, Agmon M, Gur-Yaish N, Rand D, Hayat Y, Gil E, et al. No one size fits all-the development of a theory-driven intervention to increase in-hospital mobility: the "WALK-FOR" study. *BMC Geriatr.* 2018;18(1):91.
72. Lim SH, Ang SY, Ong HK, Lee TZY, Lee TXL, Luo EZ, et al. Promotion of mobility among hospitalised older adults: an exploratory study on perceptions of patients, carers and nurses. *Geriatr Nurs.* 2020;41(5):608-14.
73. Lee-Steere K, Liddle J, Mudge A, Bennett S, McRae P, Barrimore SE. "You've got to keep moving, keep going": understanding older patients' experiences and perceptions of delirium and nonpharmacological delirium prevention strategies in the acute hospital setting. *J Clin Nurs.* 2020; 29(13-14):2363-77.
74. Rasmussen RL, Holst M, Nielsen L, Villumsen M, Andreassen J. The perspectives of health professionals in Denmark on physical exercise and nutritional interventions for acutely admitted frail older people during and after hospitalisation. *Health Soc Care Community.* 2020;28(6):2140-9.
75. Kalisch BJ. Missed nursing care: a qualitative study. *J Nurs Care Qual.* 2006;21(4):306-13 quiz 14-5.
76. Doherty-King B, Bowers BJ. Attributing the responsibility for ambulating patients: a qualitative study. *Int J Nurs Stud.* 2013;50(9):1240-6.
77. Douglas CH, Douglas MR. Patient-centred improvements in health-care built environments: perspectives and design indicators. *Health Expect.* 2005;8(3):264-76.
78. Douglas CH, Douglas MR. Patient-friendly hospital environments: exploring the patients' perspective. *Health Expect.* 2004;7(1):61-73.
79. Lafreniere S, Folch N, Dubois S, Bedard L, Ducharme F. Strategies used by older patients to prevent functional decline during hospitalization. *Clin Nurs Res.* 2017;26(1):6-26.
80. Lyon A, Solomon MJ, Harrison JD. A qualitative study assessing the barriers to implementation of enhanced recovery after surgery. *World J Surg.* 2014;38(6):1374-80.
81. Holst M, Hansen LA, Pedersen LA, Paulsen S, Valentinsen CD, Kohler M. Physical activity in hospitalized old medical patients; how active are they, and what motivates to physical activity. *J Aging Res Clin Pract.* 2015;4(2):116-23.
82. Gillis A, MacDonald B, MacIsaac A. Nurses' knowledge, attitudes, and confidence regarding preventing and treating deconditioning in older adults. *J Contin Educ Nurs.* 2008;39(12):547-54.
83. Cheah S, Presnell S. Older people's experiences of acute hospitalisation: an investigation of how occupations are affected. *Aust Occup Ther J.* 2011;58(2):120-8.
84. Parke B, Chappell NL. Transactions between older people and the hospital environment: a social ecological analysis. *J Aging Stud.* 2010;24(2):115-24.
85. van der Leeden M, Huijsmans R, Geleijn E, de Lange-de Klerk ES, Dekker J, Bonjer HJ, et al. Early enforced mobilisation following surgery for gastrointestinal cancer: feasibility and outcomes. *Physiotherapy.* 2016;102(1):103-10.
86. van Delft L, Bor P, Valkenet K, Slooter A, Veenhof C. The effectiveness of hospital in motion, a multidimensional implementation project to improve patients' movement behavior during hospitalization. *Phys Ther.* 2020;100(12):2090-8.
87. van Dijk-Huisman HC, Weemoes ATR, Boymans T, Lensen AF, de Bie RA. Smartphone App with an accelerometer enhances patients' physical activity following elective orthopedic surgery: a pilot study. *Sensors (Basel).* 2020;20(15):4317.
88. Koenders N, Potkamp-Kloppers S, Geurts Y, Akkermans R, Nijhuis-van der Sanden MWG, Hoogeboom TJ. Ban Bedcentricity: A Multifaceted Innovation to Reduce Sedentary Behavior of Patients During the Hospital Stay. *Phys Ther.* 2021;101(7):pzab054.

89. Klein LM, Young D, Feng D, et al. Increasing patient mobility through an individualized goal-centered hospital mobility program: a quasi-experimental quality improvement project. *Nurs Outlook*. 2018;66:254-62.
90. Probasco JC, Lavezza A, Cassell A, Shakes T, Feurer A, Russell H, et al. Choosing wisely together: physical and occupational therapy consultation for acute neurology inpatients. *Neurohospitalist*. 2018;8(2):53-9.
91. Cohen Y, Zisberg A, Chayat Y, Gur-Yaish N, Gil E, Levin C, et al. Walking for better outcomes and recovery: the effect of walk-for in preventing hospital-associated functional decline among older adults. *J Gerontol A Biol Sci Med Sci*. 2019;74(10):1664-70.
92. Garne-Dalgaard A, Mann S, Bredahl TVG, Stochkendahl MJ. Implementation strategies, and barriers and facilitators for implementation of physical activity at work: a scoping review. *Chiropr Man Therap*. 2019;27:48.
93. Huijg JM. Towards the effective introduction of physical activity interventions in primary health care. Enschede: University of Leiden; 2014.
94. Little EA, Presseau J, Eccles MP. Understanding effects in reviews of implementation interventions using the Theoretical Domains Framework. *Implement Sci*. 2015;10:90.
95. Prior M, Guerin M, Grimmer-Somers K. The effectiveness of clinical guideline implementation strategies--a synthesis of systematic review findings. *J Eval Clin Pract*. 2008;14(5):888-97.

CHAPTER THREE

BARRIERS AND ENABLERS TO PHYSICAL
ACTIVITY BEHAVIOUR IN OLDER ADULTS
DURING HOSPITAL STAY: A QUALITATIVE
STUDY GUIDED BY THE THEORETICAL
DOMAINS FRAMEWORK

Hanneke C. van Dijk-Huisman
Petra H. Raeven-Eijkenboom
Fabienne J. H. Magdelijns
Judith M. Sieben
Robert A. de Bie
Antoine F. Lenssen

Published in BMC Geriatrics 2022;22:314

Digital Object Identifier: 10.1186/s12877-022-02887-x

ABSTRACT

Background

Older adults admitted with an acute medical illness spent little time active during hospitalisation and this has been associated with negative health outcomes. Understanding which barriers and enablers influence the physical activity behaviour of hospitalised older adults is a first step towards identifying potentially modifiable factors and developing, evaluating and implementing targeted interventions aimed at increasing their physical activity behaviour. Using a theoretical framework has been found to be more successful in changing behaviour than using a non-theory driven approach. This study aimed to explore barriers and enablers to physical activity behaviour in older adults admitted to a hospital with an acute medical illness, as perceived by patients and healthcare professionals, and to categorise them using the Theoretical Domains Framework (TDF).

Methods

A qualitative study was conducted at a combined university and regional hospital in the Netherlands between January 2019 and February 2020. Older adults (≥ 70 years) admitted with an acute medical illness, and healthcare professionals (nurses, physicians, physiotherapists) were recruited using purposive sampling. Semi-structured interviews were audiotaped, transcribed and analysed using directed qualitative content analysis. Barriers and enablers to physical activity behaviour during hospitalisation were identified and coded using the TDF.

Results

Meaning saturation was determined after interviews with 12 patients and 16 healthcare professionals. A large number of barriers and enablers were identified and each categorised to 11 of the 14 domains of the TDF. The '*Environmental Context and Resources*' domain in particular yielded many examples, and revealed that the hospital environment exerts an inactivating influence on patients.

Conclusions

The large number of identified barriers and enablers highlights the complexity of influencing older adults' physical activity behaviour during hospitalisation. This overview of barriers and enablers to physical activity behaviour in older adults admitted to a hospital with an acute medical illness represents an initial step towards developing, evaluating and implementing theory-informed behaviour change interventions to improve hospitalised older adults' physical activity levels. It can assist clinicians and researchers in selecting modifiable factors that can be targeted in future interventions.

INTRODUCTION

Older adults admitted to hospital with an acute medical illness spend little time active. They spend an average of 30 to 117 min a day standing or walking; the remainder of the day is spent lying in bed or sitting in a chair¹⁻⁸. Regardless of illness severity or comorbidities, this inactive behaviour is strongly associated with functional decline, increased length of hospital stay, increased risk of institutionalisation, and mortality^{1,2,4,5,8-15}. These older adults are already at high risk of negative outcomes due to a high prevalence of multi-morbidity and age-related impairments, such as a decreased physiological reserve capacity, malnutrition, cognitive impairment, incontinence, and sensory impairment¹⁶. Therefore, interventions aimed at improving the physical activity (PA) behaviour of older adults during hospitalisation are needed to improve patient outcomes¹⁷.

Such interventions are more likely to be effective if they are designed to target underlying factors that influence behaviour¹⁸. Understanding which barriers and enablers influence the PA behaviour of hospitalised older adults is a first step towards identifying potentially modifiable factors and developing, evaluating and implementing targeted interventions¹⁸⁻²⁰.

Several studies have investigated barriers and enablers to PA behaviour during hospital stay for acute care in older adults, from the perspectives of patients^{17,21}, healthcare professionals (HCPs)²²⁻²⁴ or both²⁵⁻²⁷. Brown et al. were the first to explore barriers to PA from the perspectives of patients and HCPs. They identified patient-related barriers (e.g., symptoms), treatment-related barriers (e.g., bed rest orders), institutional barriers (e.g., availability of assistance) and attitudinal barriers (e.g., concerns about falling)²⁷. Following studies identified additional barriers and enablers, such as HCPs prioritising other care processes over promoting PA^{22,24,25}, patients being attached to IV-poles or other medical devices^{22,25}, HCPs' lack of training on how to safely mobilise hospitalised patients²³, patients receiving encouragement from HCPs¹⁷, and patients wanting to prevent the negative effects associated with bed-rest¹⁷.

The use of theories of behaviour or behaviour change has been found to be more successful in changing behaviour than using a non-theory driven approach^{28,29}. As the Medical Research Council guidance on the development of complex interventions advocates the use of theory to identify barriers and enablers to behaviour change³⁰, our study expanded on previous studies by adopting a theoretical framework to categorise barriers and enablers. As a large number of theories of behaviour and behaviour change have been developed, selecting an appropriate theory can be challenging. The Theoretical Domains Framework (TDF) is an overarching theoretical framework in which constructs of 33 theories of

behaviour and behaviour change are integrated and simplified into 14 domains³¹. It is developed to make theories more accessible and was chosen for this study due to its inclusive nature, incorporating cognitive, affective, social and environmental influences on behaviour²⁹. It enables a systematic and theory driven approach to categorise barriers and enablers into the fourteen domains. Moreover, it can guide the development of interventions by linking potentially modifiable factors to intervention functions and behaviour change techniques (BCTs)^{29,31-34}. The objective of our study was to explore and categorise patient- and HCP-perceived barriers and enablers to PA behaviour in older adults admitted to a hospital with an acute medical illness, using the TDF.

METHODS

Study design

This qualitative study used semi-structured interviews to explore barriers and enablers to PA behaviour in older adults admitted to hospital with an acute medical illness. Directed qualitative content analysis was performed using the TDF, and overarching themes were identified within each domain. This study was conducted at the Department of Internal Medicine of Maastricht University Medical Centre (MUMC+) in Maastricht, the Netherlands, between January 2019 and February 2020. The consolidated criteria for reporting qualitative research (COREQ) were applied to report this study (Additional file 1)³⁵.

Setting and research group

The MUMC+ is a 715-bed, combined university and regional hospital. The Department of Internal Medicine can accommodate 33 patients with a nurse to patient ratio of 1:6. Patients are admitted to single, double, or four-bed rooms. The ward has a communal 'living room' and an exercise room. Nursing assistants, nutritionists and physiotherapists help mobilise, feed, and monitor patients. On weekdays, the physiotherapist is present at the ward for 2.5 h.

The research group consisted of one health scientist (JMS), four health scientists with a background as physiotherapists (HCvDH, PHRE, AFL, RAdB), and one geriatrician (FJHM). HCvDH and AFL were involved in a care programme to improve the PA behaviour of patients during hospital stay. HCvDH and FJHM worked at the ward and had been treating some of the patients.

Participant selection and recruitment

Patients were sampled purposively by consulting HCPs, in order to include a variety of medical conditions, sex and age. Older adults admitted to the Department of Internal Medicine at MUMC+ were recruited by their attending physician and were asked to consent to being contacted by the researcher (HCvDH). Patients received verbal and written information about the study from the researcher within 48 h after admittance. Patients were contacted again 3 days later, and written informed consent was obtained before study initiation.

Eligible patients were included if they were 70 years or older, had been admitted with an acute medical illness, were able to verbally communicate in Dutch (i.e., no language barrier or aphasia), had been living at home before hospitalisation, and had been able to walk independently on level surface with or without a walking aid 2 weeks before admission, as reported using the Functional Ambulation Categories (FAC >3)^{36,37}. Patients were excluded if the attending physician had reported in the electronic medical record that patients had contraindications to walking, were mentally incapacitated, were unable to be interviewed due to cognitive problems or severe agitation, or had a life expectancy of less than 3 months. In case of any doubt, patients were not considered eligible. Patients who had previously participated in this study were excluded as well.

For every included patient, an HCP involved with this patient was also recruited. Nurses, physiotherapists and physicians (including resident physicians) who had been working at the hospital for more than 1 month were eligible. HCPs were sampled purposively by the researcher to include a variety of professions, work experience, sex and age. HCPs received verbal and written information about the study from the researcher. They were contacted again 3 days later and written informed consent was obtained before study initiation. Confidentiality of data processing and pseudonymisation of participants were guaranteed.

Data collection

Semi-structured, face-to-face individual interviews were conducted by two researchers (HCvDH, PHRE) experienced in qualitative research. Patients were interviewed on day 4–6 after admission, thus ensuring they had had sufficient time to experience barriers and enablers to PA behaviour during their hospitalisation. HCPs were interviewed within 7 days of the patient interview. A semi-structured interview approach was used with open questions. Separate interview guides were created for patients (Additional file 2) and HCPs (Additional file 3) based on existing literature on barriers and enablers to PA behaviour^{17,27,38,39}. To provide maximum opportunity for the participants to answer in their own words and direction, the interview guides were not based on the domains of the TDF. The interview guides

were piloted by interviewing one patient and three HCPs. Pilot interviews were not included in the final sample. Interviews were conducted by two different interviewers to avoid bias by a single interviewer's style and to enhance confirmability. Before the first interviews started, the interviewers discussed their own views on barriers and enablers to PA behaviour during hospitalisation, with the aim of increasing awareness of feelings and opinions. Interviews were conducted in a separate room at the ward to guarantee privacy. They were expected to last approximately 30 min and were audiotaped. When starting the interview, the interviewers introduced themselves and briefly explained the objectives of the interview. Notes were taken during the interview to capture observations and initial interpretations. Member checking was performed by providing a verbal summary of the interview to the participant. Interviews were transcribed full verbatim and reviewed by two researchers (HCvDH, PHRE) to verify content. Participants were offered the opportunity to read the transcript, to offer comments or additional thoughts.

Demographic data was collected at the start of the interview. Patients were asked for their age, sex, ability to walk independently on the day of the interview (yes/no), type of walking aid used on the day of the interview, whether they had received one or more physiotherapy sessions during hospitalisation (yes/no) and the amount and type of PA they had performed in the 2 weeks prior to hospitalisation. HCPs were asked for their age, sex, profession, and how long they had been working at the MUMC+ Department of Internal Medicine.

Theoretical domains framework

The validated TDF comprises 84 theoretical constructs from 33 theories of behaviour and behaviour change, embedded in 14 domains: *Knowledge, Skills, Social/Professional Role and Identity, Beliefs about Capabilities, Optimism, Beliefs about Consequences, Reinforcement, Intentions, Goals, Memory, Attention and Decision Processes, Environmental Context and Resources, Social Influences, Emotion, and Behavioural Regulation*^{29,40}. The TDF has been applied across a wide range of healthcare settings and clinical behaviours^{29,31}. It has been extensively used as a guide to identify and categorize barriers and enablers to PA in other populations and settings such as at school⁴¹, at work⁴², among older adults living with HIV⁴³, in asylum seekers⁴⁴, and in stroke survivors⁴⁵.

Data analysis

Directed qualitative content analysis as described by Hsieh and Shannon was used as an approach to organise and analyse the data⁴⁶. An a-priori coding template was developed based on the 14 domains of the TDF. Analysis started after two interviews had been completed. Two researchers (HCvDH and PHRE) independently

read and re-read each transcript and coded barriers and enablers using the TDF domains. The theoretical definitions and component constructs of the domains, as presented in Additional file 4, were used to guide the coding process. Barriers and enablers were coded separately, and were assigned to more than one domain if the content suited multiple domains. The researchers discussed coding discrepancies and iteratively modified the coding template after every two interviews. Any discrepancies resulted in reviewing the data and codes. If necessary, a senior researcher (AFL) was consulted to discuss and resolve disputes. An audit trail was created and new or changed codes were documented during every iteration, including a definition of each code and a description of the issues it captured. Emerging themes were explored in subsequent interviews and this process was repeated until a final coding template had been developed and meaning saturation was observed by the researchers. Meaning saturation was defined as the point where a full understanding was created of the issues, and when no further dimensions, nuances, or insights of issues were found⁴⁷. This was assessed separately for patients and HCPs. Two additional interviews were conducted per group to ensure that no new information was discovered and saturation was achieved, after which inclusion of patients or HCPs ended. Confirmability of the outcomes was enhanced by creating an audit trail. NVivo (QSR International Pty Ltd. [2018] NVivo [Version 12]) software was used to facilitate data analysis.

Finally, a descriptive summary of the reported barriers and enablers was composed for each TDF domain. Quotes from participants' transcripts were included as illustrations. Dutch quotes and code labels were translated into English and checked by a professional translator/ editor for correct conveyance of their meaning⁴⁸.

RESULTS

Participants

Thirty potential participants were approached. Twenty-eight of them (12 patients, 6 nurses, 5 physiotherapists, and 5 physicians) were included in the study. Two patients declined participation. Meaning saturation occurred after 10 patient and 14 HCP interviews. Subsequent interviews did not provide additional information regarding the understanding of issues, resulting in a total of 12 patient and 16 HCP interviews. Characteristics of patients and HCPs are summarised in Tables 3.1 and 3.2, respectively. The median (interquartile range [IQR]) age of the patients was 83 (75-85) years and 7 patients (58.3%) were male. The duration of the patient interviews ranged from 27 to 57 min. The median (IQR) age of the HCPs was 27 (24-33) years and 3 HCPs (18.8%) were male. The duration of the HCP interviews ranged from 33 to 61 min.

Table 3.1 Patient characteristics.

Patient code	Sex	Age (years)	Ability to walk independently on the day of the interview	Walking aid	Received PT during hospital stay	PA performed 2 weeks prior to admission
P0001	Male	84	Yes	Walker	Yes	-Walking in and around the house (50-60 m.)
P0002	Female	71	Yes	Walker	Yes	-Fitness (1 hour per week) -Walking (<1 km) -Cycling to grocery store -Volunteer work at elderly home
P0003	Male	83	Yes	Walker	Yes	-Walking inside the house
P0004	Male	82	Yes	Walker	No	-Walking inside the elderly home -Dancing (behind the walker) -Performing activities of daily living
P0005	Male	85	Yes	None	No	-Nordic walking (5 km) -Volunteer work (walking, repairing bicycles) -Doing groceries
P0006	Female	82	Yes	Walker	Yes	-Walking (30 minutes per day) -Performing household activities
P0007	Male	91	Yes	Cane	No	-Walking (once per week, 1 km) -Doing groceries -Performing household activities
P0008	Female	75	Yes	Walker	No	-No physical activity performed, only lying in bed
P0009	Female	75	Yes	None	Yes	-Performing household activities
P0010	Male	87	Yes	None	Yes	-Walking (200-300m. per day) -Performing household activities
P0011	Male	83	Yes	None	Yes	-Walking to grocery store (350 m) -Performing household activities
P0012	Female	73	No	Walker	Yes	-Swimming (once per week) -Walking to grocery store (twice per week, <1 km.) -Following an exercise program on the television

PT=Physiotherapy, PA=Physical activity

Table 3.2 Healthcare professional characteristics.

Patient code	Sex	Age (years)	Profession	Work experience (months / years)
H3001	Female	28	Physiotherapist	6 months
H2002	Male	27	Physician	1 year
H1003	Female	25	Nurse	8 years
H2004	Female	24	Physician	4 months
H2005	Female	24	Physician	3 years
H1006	Female	25	Nurse	4 years
H1007	Female	27	Nurse	3 years and 6 months
H2008	Female	23	Physician	4 months
H3009	Female	27	Physiotherapist	3 years and 11 months
H2010	Female	33	Physician	8 years and 7 months
H3011	Female	32	Physiotherapist	10 years
H3012	Female	25	Physiotherapist	2 years and 6 months
H1013	Male	48	Nurse	13 years and 11 months
H1014	Female	54	Nurse	36 years
H3015	Female	35	Physiotherapist	12 years and 6 months
H1016	Male	24	Nurse	4 years

Theoretical domains framework

A complete overview and a visualisation of the TDF coding of all barriers and enablers are provided in Additional file 5 and Figure 3.1, respectively. No barriers were assigned to the domains of *Optimism*, *Reinforcement*, and *Behavioural Regulation*. No enablers were assigned to the domains of *Reinforcement*, *Memory*, *Attention and Decision Process*, and *Emotion*.

1. Knowledge

Patients and HCPs described that patients, visitors, and HCPs are not always aware that it is important for patients to stay active during hospitalisation, or what patients could do to stay active. HCPs suggested explaining expectations regarding PA to patients and visitors prior to admission. Patients and HCPs also perceived a lack of knowledge of patients' functional capabilities as a barrier, while having this knowledge was perceived as an enabler.

*H1006: 'Often you don't know to what extent patients are able to stand. And that's the reason why we didn't *get* patients like this one out of bed.'*

Other barriers described were a lack of knowledge about walking aids and opportunities to be active despite being attached to medical devices (e.g., an IV-pole).



Figure 3.1 Visualisation of the TDF coding of barriers and enablers to PA behaviour in hospitalised older adults. TDF=Theoretical Domains Framework, PA=physical activity, HCP=healthcare professional

2. Skills

Being dependent on HCPs or visitors during PA was reported as a barrier by patients and HCPs, while being independent was reported as an enabler. Main reasons for being dependent were reduced physical capabilities, perceived risk of falls, and cognitive impairments.

H2004: 'He wasn't even able to get out of bed and stand-up without assistance. And so I think feeling insecure about walking is holding him back, the fact that his fall risk would increase if he did it alone, so he's actually dependent on someone else to become active.'

HCPs identified a lack of skills to assist patients during PA as a barrier, while having these skills was identified as an enabler. Nurses questioned whether all volunteers and visitors have these skills.

3. Social/professional role and identity

HCPs described that older adults may adopt a 'sick role' during hospitalisation and that these patients feel that they do not need to be active. They believe that they should remain in bed and often adopt a more dependent attitude than necessary.

H1014: 'In general, I think older people always assume they have to stay in bed because they are sick.'

Patients and HCPs also identified different professional roles within a multidisciplinary team as enablers (Table 3.3). The status of a physician was mentioned by many HCPs as an important influence on patients' decision to become active.

H1006: 'When they hear it from their physician they jump out of bed, and when they hear it from us [nurses] it's: "oh girl, why don't you just go to the next patient".'

Table 3.3 Social/Professional roles of different professions identified as enablers.

Profession	Role	Reported by			
		P	N	PH	PT
Physician	Status of a physician		x	x	x
	Providing patients with information on the importance of PA during hospitalisation		x	x	
Nurse	Referring patients to therapy services		x	x	x
	Providing patients with information on the importance of PA during hospitalisation		x	x	
	Assessing functional capabilities		x	x	x
	Providing encouragement and assistance during PA		x		x
	Providing walking aids		x	x	
Physiotherapist	Training other nurses in safe patient handling and mobility		x		
	Providing patients with information on the importance of PA during hospitalisation	x	x	x	x
	Assessing functional capabilities and risk of inactive behaviour		x	x	x
	Assessing fall risk and fear of falling			x	x
	Providing encouragement and assistance during PA		x		x
	Providing walking aids			x	x
	Instructing group exercise classes		x		x
	Providing supervision in exercise rooms	x			x
	Stimulating prevention				x
	Coaching patients, visitors and other HCPs	x	x	x	x
Educating other HCPs on the importance of PA during hospitalisation				x	
Training other HCPs in safe patient handling and mobility		x		x	

P=patient; N=nurse; PH=physician; PT=physiotherapist; PA=physical activity; HCP=healthcare professional.

Moreover, having a dedicated multidisciplinary team in which everyone perceives a responsibility to promote PA behaviour was seen as important. However, nurses, physicians and physiotherapists also described that not all HCPs perceive a responsibility to promote PA behaviour. They explained that this responsibility is often attributed to other disciplines, mostly physiotherapists.

4. Beliefs about Capabilities

Patients and HCPs described that patients who lack confidence in their own functional capabilities are less active than those who are confident about them.

P0011: 'Feeling insecure about falling... not being stable enough... That's what I fear most... and then I think "I hope I don't fall, I hope I don't get too dizzy..." These thoughts shouldn't come into my mind, but they do.'

5. Optimism

No barriers emerged within this domain. Both patients and HCPs described that patients who adopt a positive attitude are more likely to be active.

P0002: 'I walk my usual round every day because it's in my nature. But then I think, people who don't do that ... get up, just walk one or two rounds. A little further each day. Yes, also to ensure that you get out of that vicious circle of "I'm not able to do it". And don't think about it too long, you must make sure that you get better, don't dwell on it. But again, I'm a very positive person, fortunately.

6. Beliefs about Consequences

Many patients described that they were active because they believed that PA stimulated their recovery and physical fitness.

P0005: 'I love being active. I just wanted to be fit. And you can't do that if you're lying down.

Two nurses described that they preferred patients to remain at the ward because otherwise they would not be able to reach them.

7. Reinforcement

No barriers or enablers emerged within this domain.

8. Intention

Nearly all participants discussed patients' motivation. Many patients felt motivated to engage in PA to prevent the negative effects of inactivity or to experience the positive effects of PA. However, feeling sick, being delirious, not perceiving the need to be active, not wanting to leave the ward, and a lack encouragement from others were reported to decrease patients' motivation. HCPs also discussed their own motivation to encourage and assist patients. Having a dedicated team, motivated to encourage and assist patients during PA was perceived as an enabler.

H1007: 'We really are a department where patients are mobilised in a chair after the morning care round. In the afternoon they are allowed to lie in bed for an hour, but after that they have to get out of bed again. We really are a department that gets everyone out of bed or motivates them to walk to the living room, instead of using a wheelchair.'

However, they also explained that their motivation was closely associated with their workload.

H1014: 'When we have little time it's just faster to take someone to the living room in a wheelchair. Usually this is caused by lack

of time. However, many people would actually be able to walk there.'

9. Goals

Patients and HCPs explained that patients need a reason to get out of bed, walk around or exercise. However, purposeful, meaningful activities are often lacking during a hospital stay. To prevent sedentary behaviour, they suggested using goalsetting and providing patients with targets to accomplish.

P0005: 'You are active because you have a goal, right. At home you go to the shop or do some cleaning or whatever. You don't have that here of course; you don't have a specific goal here.'

Wanting to prevent the negative effects associated with inactivity (e.g., functional decline, becoming dependent on others, pulmonary complications, pressure ulcers, pain and stiffness, deep vein thrombosis, and mortality) was described by patients and HCPs as a reason to either become active or to promote PA behaviour. Patients additionally described wanting to experience the positive effects of PA (e.g., recovery, regaining physical fitness, regaining self-confidence, going home), as well as preventing boredom, seeking distraction, wanting to smoke, and wanting privacy.

10. Memory, attention and decision process

Although no enablers emerged within this domain, the difficulty of prioritising PA during hospitalisation was often discussed as a barrier. Patients and HCPs reported that patients tend to prioritise care rounds, examinations, visitors and resting over PA. HCPs also explained that lack of time, insufficient staffing, or having high acuity patients at the ward often led to other tasks getting priority over promoting patients' PA behaviour, even though they were aware of the importance of it.

H1006: 'I was the only [registered] nurse for these patients and I had an intern with me. Because I was busy with so many things, I didn't get a chance to stimulate other patients [to be active]. Yes, and then you have to set priorities. What's more important? Someone with a life-threatening situation like today...'

11. Environmental context & resources

A visualisation of the TDF coding of all barriers and enablers into the domain of *Environmental Context and Resources* is provided in Figure 3.2.

Care processes and organisational characteristics

HCPs described that many different care processes are concentrated around the hospital bed, such as physician rounds or medication rounds. This 'bed-centred care' is thought to have an inactivating effect on patients, while care processes aimed at maintaining or improving independence in activities of daily living (i.e., providing 'function focused care') were described as activating.

P0011: 'They shouldn't bring meals to the bed. Yes, of course it's easier if I get it in bed, but eating should be done at a table. You can eat at a table, but it's not required. They should say: "Your dinner is ready at the table or in the hallway, you should go and get it".'

HCPs described that many patients are not aware of their daily schedule and stay in their room because they are afraid to miss HCPs. Providing a structured daily schedule with care processes scheduled at predefined times was suggested to reduce unnecessary waiting and create more time for PA. Other barriers reported by patients and HCPs are using physical restraint and freedom-restricting measures, as well as being attached to IV-poles, drains, or urinary catheters. As a solution, HCPs proposed minimising their use, or facilitating PA despite these restrictions. Furthermore, care processes related to communication and collaboration between nurses, physiotherapists, and physicians were described by HCPs as either a barrier or an enabler.

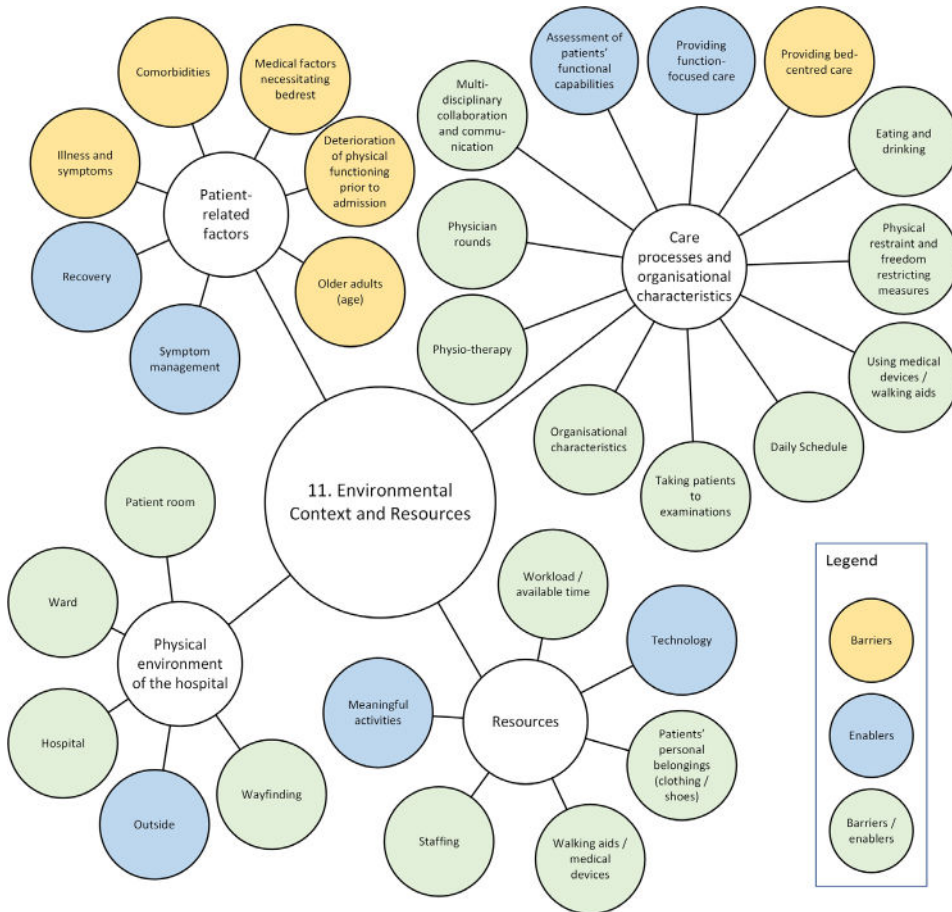

Figure 3.2 Visualisation of the TDF coding of barriers and enablers to the domain of Environmental Context and Resources. TDF=Theoretical Domains Framework

Patient-related factors

Medical factors and ageing were identified as barriers by many patients and HCPs. Illness and accompanying symptoms (i.e., fatigue, pain, dizziness, weakness, reduced exercise capacity, dyspnoea, poor balance, hypotension, nausea, oedema, diarrhoea) were reported many times, but deterioration of physical functioning prior to hospitalisation, comorbidities (e.g., cognitive problems, obesity, visual and hearing impairments) and medical conditions requiring bedrest were also mentioned.

H1016: 'Being ill is just the biggest barrier. Not feeling well and being in pain. I think pain is a very important factor. If the pain is bearable then patients are more likely to get out of bed.'

By contrast, recovery and managing symptoms (i.e., optimising pain medication or blood pressure) were associated with being more active.

Physical environment of the hospital

The influence of the physical environment was mentioned many times, mostly by HCPs. Patient' rooms were seen as inactivating as they offer insufficient space and lack suitable furniture, with a television set hanging right above the bed. HCPs suggested creating separate areas for sleeping and daytime activities, implementing measures to prevent spending too much time in bed, and providing every room with an exercise bike.

H3015: 'It's very important to have a space where patients can eat or sit comfortably with their visitors. They should also be able to watch TV there, as currently patients have to lie in bed to watch TV.'

Patients described the corridors as boring, cluttered, busy, and lacking places to sit or get coffee. Some described the need for a living room at the ward to socialise, eat, play games, or engage in craft work, while others did not perceive this need. Having an exercise room at the ward was also perceived as an enabler, although some participants did not know it was available. To make the environment of the ward and hospital more activating, patients and HCPs suggested creating more exercise facilities, places to sit, a coffee corner and possibilities to walk outside. They also described a need for organised activities such as craft work, musical and theatre performances. Moreover, as some patients were afraid of getting lost in the hospital, clearer signage, graphic symbols and walking routes were suggested to improve wayfinding.

Resources

A high workload and lack of time to promote PA were mentioned by many HCPs. This was often aggravated by a limited availability of staff, especially during weekends and evenings.

H1006: 'So in the end you don't have enough staff to take everyone [patients] for a walk...'

On the other hand, having sufficient time to promote PA was described as an enabler. Furthermore, the availability of equipment (e.g., walking aids, wheelchairs, drain bag holders, lifting devices, portable oxygen tanks, antiskid socks) and technology (e.g., virtual bike rides, gaming, virtual reality, interactive projections) were reported to be enablers.

12. Social influence

Patients explained the importance of receiving encouragement and assistance from HCPs or visitors, because intrinsic motivation and other reasons to become active are often lacking during hospitalisation. Many described that they received less encouragement and assistance than they would have preferred.

P0009: 'Yes, you have to give people instructions. You don't have to obey them, that's up to you of course. But you need encouragement; subconsciously you know that it's important, but you need to hear it from someone else and then it's much more credible. Only then will it fully sink in.'

On the other hand, patients and HCPs also described that HCPs sometimes provided more assistance than necessary. Additionally, HCPs reported that they should stimulate visitors more often to take patients for a walk, instead of sitting around.

13. Emotion

No enablers emerged within this domain. Patients and HCPs reported that fear of falling or getting lost were barriers. They also described that patients may feel embarrassed to be seen walking around with a urinary catheter, drain or IV-pole.

H3015: 'Often patients are ashamed to walk with all these drains or a urinary catheter.'

14. Behavioural regulation

No barriers emerged within this domain. Patients and HCPs frequently mentioned the importance of providing information and education. Patients, visitors and HCPs need to be informed regarding the importance of staying active during hospitalisation, as well as regarding patients' functional capabilities and the options available to stay active. Suggested modes of delivery were: face-to-face, brochures, posters, e-mail, TV and internet. Other strategies suggested to regulate behaviour were using mobility champions, using patient communication boards, providing regular training sessions, and regularly discussing functional capabilities within the team. HCPs also mentioned the importance of receiving practical skills training in safe patient handling and mobility. Furthermore, many HCPs discussed using technology (e.g., wearables, digital patient portals, tablets) as a strategy to promote PA behaviour. Physiotherapists highlighted the advantage of wearable activity monitors to assess patients' PA levels and to set goals.

H1014: 'They always say: "Older adults, they can't [deal with technology]". I don't know about that. I think that you should try it. I rather think that they don't know what it's like or how it works. I think they may surprise us

DISCUSSION

To our knowledge, this is the first qualitative study to explore barriers and enablers to PA behaviour in older adults admitted to hospital with an acute medical illness, and to categorise them using the TDF. Our results offer an overview of barriers and enablers assigned to 11 of the 14 TDF domains, with the domain of *Environmental Context and Resources* being particularly elaborately described. Our findings highlight the complexity of influencing older adults' PA behaviour during hospitalisation. Barriers and enablers were often reported as opposites, with the absence of a factor perceived as a barrier and its presence as an enabler. Although patients and HCPs reported many similar factors, HCPs reported a larger number of barriers and enablers as they perceive them from a broader perspective. While patients are hospitalised for a relatively short period and focus on their own illness, HCPs experience the hospital environment for a much longer period and provide care to many different patients. They take into account their patients' as well as their own perspectives, hence perceiving more factors relating to care processes and organisational characteristics. The differences between patients' and HCPs' perspectives emphasise that both should be taken into account to gain a complete understanding of factors that influence older adults' PA behaviour during hospitalisation. This setting-specific overview of barriers and enablers represents an initial step in developing, evaluating, and implementing theory-informed behaviour change interventions aimed at improving hospitalised older adults' PA behaviour. It can assist clinicians and researchers in selecting modifiable factors that can be targeted in future interventions. Given that barriers and enablers may differ between settings and cultures, our overview can assist other settings in performing a setting-specific assessment to determine what needs to change to improve older adults' PA behaviour in a different context. The current study yielded many barriers and enablers that will also be applicable to other contexts.

Within the domain of *Environmental Context and Resources*, our results confirm previous studies indicating that the hospital environment has an inactivating influence on patients^{27,49-51}. Care is organised around the hospital bed, with patients waiting for physician and nursing rounds, therapy services, visitors, and distribution of food or medication. Since patients are insufficiently aware of their daily schedule, they adopt a passive role and stay in their rooms, afraid to miss HCPs. Moreover, the physical environment and lack of available resources do not encourage patients to become active. Our study identified a number of factors within the domain of *Environmental Context and Resources* that were not identified in previous studies^{17,21-27}, such as unnecessary waiting for HCPs (and ways to reduce this), the use of a bed or wheelchair to take patients to examinations, creating separate areas for sleeping and daytime activities, the availability of technology (e.g., interactive projections, virtual bike rides), attractive places (e.g., coffee corner,

exercise room, garden) and activities (e.g., exhibitions, games, crafts, performances). To create a hospital culture aimed at improving older adults' PA behaviour, our findings suggest that clinicians and researchers should consider reorganising care processes and organisational processes, restructuring the physical hospital environment and creating sufficient resources.

Our findings also suggest the importance of the domains of *Knowledge* and *Skills*. Awareness of the importance of PA, patients' functional capabilities, and the available options to stay active are essential to encourage patients to become active during hospitalisation. Similarly, this awareness and having the skills to assist patients during PA are essential for HCPs, visitors and volunteers in order to encourage and assist patients. Doherty-King et al. supported this notion by describing how nurses considered their own abilities and experiences when deciding whether and how to mobilise patients²⁴. Having knowledge and skills may positively influence other domains, such as *Intention* (e.g., motivation), *Beliefs about Consequences* (e.g., believing that PA is necessary for recovery), *Social/Professional Role and Identity* (e.g., fewer patients adopting a 'sick role' and more HCPs perceiving responsibility to promote PA) and *Beliefs about Capabilities* (e.g., nurses' confidence about assisting patients). To improve knowledge and skills, many of the patients and HCPs would have liked to receive more information, education or practical skills training. Suggested strategies to accomplish this were using mobility champions, providing regular training sessions, using patient communication boards to visualize functional capabilities, and providing information face-to-face, via brochures or on TV. However, even when knowledge and skills are optimal, patients' PA behaviour may still be impaired by other factors, such as pain or HCPs' lack of time. Furthermore, many other modifiable factors were identified in the remaining domains, demonstrating the complexity of changing older adults' PA behaviour during hospitalisation.

Given the large number of factors influencing the PA behaviour of hospitalised older adults, we recommend that clinicians and researchers develop, evaluate, and implement interventions targeted at multiple factors. Previous research suggests that such tailored multimodal interventions may be more effective than unimodal interventions⁵². In selecting which factors to target, clinicians and researchers should consider the impact and likelihood of changing patients' PA behaviour and the ease of measurement when evaluating interventions. Selected factors can subsequently be linked to specific intervention functions and behaviour change techniques (i.e., active intervention components)^{29,32,40,53}. An available framework that may be useful to assist clinicians and researchers in selecting appropriate intervention functions is the Behaviour Change Wheel (BCW). The BCW offers a structured approach for the development of behaviour change interventions. It is a synthesis of 19 frameworks of behaviour change that is designed to link determinants of behaviour (using the

TDF) to appropriate intervention functions and behaviour change techniques³². Additionally, the APEASE criteria (affordability, practicability, effectiveness and cost-effectiveness, acceptability, side-effects/safety, equity) could be useful in making strategic judgements in choosing the most appropriate intervention³².

Strengths and limitations

A strength of this study is the use of the TDF as a theoretical framework to categorise and understand barriers and enablers to PA behaviour in hospitalised older adults^{29,40}. Moreover, we have provided an in-depth description of factors that influence patients' PA behaviour, by exploring barriers and enablers from a broad scope of perspectives of patients, nurses, physicians, and physiotherapists. For each patient, one of their HCPs was included as well, to explore different perspectives on the same situations. Lastly, almost all aspects of data collection and analysis were carried out by two researchers, with a third party available to solve disagreements.

We also acknowledge some limitations. While the TDF allows barriers and enablers to be explored from a broad perspective, it does not provide insight into the ways they interact with each other. Moreover, although an overview of theoretical definitions and component constructs was used to guide the coding process, it was difficult to differentiate between some TDF domains (e.g., *Knowledge* and *Beliefs about Consequences*), as has also been reported by other studies^{41,54}. Furthermore, a limited number of demographic variables were collected for patients and HCPs. Providing additional patient characteristics (e.g., medication use or length of hospital stay) could have improved the understanding of patients' PA behaviour. Moreover, information regarding HCPs' own PA behaviour would have been valuable as this may have influenced HCPs' thoughts and actions related to patients' PA behaviour. Lastly, the majority of included HCPs were female with a relatively young median (IQR) age of 27 (24-33) years, and most physicians were resident physicians. Although this is thought to be an accurate representation of the population of HCPs in the Department of Internal Medicine, barriers and enablers may be perceived differently by younger and older, more experienced HCPs.

Recommendations for future research

Further research is needed to develop and validate a TDF-based questionnaire that could facilitate a setting-specific assessment of barriers and enablers to PA behaviour in hospitalised older adults across all TDF domains. Moreover, few studies have investigated the efficacy or effectiveness of existing interventions aimed at improving the PA behaviour of older adults during hospitalisation⁵⁵⁻⁵⁸. Therefore, further studies are needed to develop, evaluate and implement theory-informed multimodal interventions that target setting-specific barriers and enablers to PA behaviour in hospitalised older adults.

CONCLUSIONS

This study has yielded an overview of barriers and enablers to PA behaviour in hospitalised older adults admitted to a hospital with an acute medical illness, and has categorised them using the TDF. The large number of barriers and enablers identified highlights the complexity of influencing older adults' PA behaviour during hospitalisation. We therefore recommend that clinicians and researchers develop interventions targeted at multiple factors. Our overview represents an initial step towards developing, evaluating, and implementing theory-informed behaviour change interventions to improve hospitalised older adults' PA behaviour. It can assist clinicians and researchers in selecting modifiable factors that can be targeted in future interventions.

SUPPLEMENTARY INFORMATION

Additional file 1 to 5 can be found online: <https://doi.org/10.1186/s12877-022-02887-x>.

ACKNOWLEDGEMENTS

We would like to thank all physiotherapists, nurses and physicians and the management at the Department of Internal Medicine of the MUMC+ for their assistance in this study. We would also like to thank Jan Klerkx who provided language editing services.

REFERENCES

1. Brown CJ, Redden DT, Flood KL, Allman RM. The underrecognized epidemic of low mobility during hospitalization of older adults. *J Am Geriatr Soc.* 2009;57(9):1660-5.
2. Ostir GV, Berges IM, Kuo YF, Goodwin JS, Fisher SR, Guralnik JM. Mobility activity and its value as a prognostic indicator of survival in hospitalized older adults. *J Am Geriatr Soc.* 2013;61(4):551-7.
3. Fisher SR, Goodwin JS, Protas EJ, Kuo YF, Graham JE, Ottenbacher KJ, et al. Ambulatory activity of older adults hospitalized with acute medical illness. *J Am Geriatr Soc.* 2011;59(1):91-5.
4. Pedersen MM, Bodilsen AC, Petersen J, Beyer N, Andersen O, Lawson-Smith L, et al. Twenty-four-hour mobility during acute hospitalization in older medical patients. *The journals of gerontology Series A, Biol Sci Med Sci.* 2013;68(3):331-7.
5. Evensen S, Sletvold O, Lydersen S, Taraldsen K. Physical activity among hospitalized older adults - an observational study. *BMC Geriatr.* 2017;17(1):110.
6. Villumsen M, Jorgensen MG, Andreasen J, Rathleff MS, Molgaard CM. Very Low Levels of Physical Activity in Older Patients During Hospitalization at an Acute Geriatric Ward: A Prospective Cohort Study. *J Aging Physical Activity.* 2015;23(4):542-9.
7. Hartley P, DeWitt AL, Forsyth F, Romero-Ortuno R, Deaton C. Predictors of physical activity in older adults early in an emergency hospital admission: a prospective cohort study. *BMC Geriatr.* 2020;20(1):177.
8. Pavon JM, Sloane RJ, Pieper CF, Colón-Emeric CS, Cohen HJ, Gallagher D, et al. Accelerometer-Measured Hospital Physical Activity and Hospital-Acquired Disability in Older Adults. *J Am Geriatr Soc.* 2020;68(2):261-5.
9. Brown CJ, Friedkin RJ, Inouye SK. Prevalence and outcomes of low mobility in hospitalized older patients. *J Am Geriatr Soc.* 2004;52(8):1263-70.
10. Covinsky KE, Palmer RM, Fortinsky RH, Counsell SR, Stewart AL, Kresevic D, et al. Loss of independence in activities of daily living in older adults hospitalized with medical illnesses: increased vulnerability with age. *J Am Geriatr Soc.* 2003;51(4):451-8.
11. Covinsky KE, Pierluissi E, Johnston CB. Hospitalization-associated disability: "She was probably able to ambulate, but I'm not sure". *JAMA.* 2011;306(16):1782-93.
12. Zisberg A, Shadmi E, Sinoff G, Gur-Yaish N, Sruлович E, Admi H. Low mobility during hospitalization and functional decline in older adults. *J Am Geriatr Soc.* 2011;59(2):266-73.
13. Mahoney JE, Sager MA, Jalaluddin M. Use of an ambulation assistive device predicts functional decline associated with hospitalization. *J Gerontol A Biol Sci Med Sci.* 1999;54(2):M83-8.
14. McCullagh R, Dillon C, Dahly D, Horgan NF, Timmons S. Walking in hospital is associated with a shorter length of stay in older medical inpatients. *Physiol Meas.* 2016;37(10):1872-84.
15. Fisher SR, Graham JE, Ottenbacher KJ, Deer R, Ostir GV. Inpatient Walking Activity to Predict Readmission in Older Adults. *Arch Phys Med Rehabil.* 2016;97(9 Suppl):S226-31.
16. Buurman BM, Hoogerduijn JG, de Haan RJ, Abu-Hanna A, Lagaay AM, Verhaar HJ, et al. Geriatric conditions in acutely hospitalized older patients: prevalence and one-year survival and functional decline. *PLoS One.* 2011;6(11):e26951.
17. So C, Pierluissi E. Attitudes and expectations regarding exercise in the hospital of hospitalized older adults: a qualitative study. *J Am Geriatr Soc.* 2012;60(4):713-8.
18. Moore JE, Mascarenhas A, Marquez C, Almaawiy U, Chan WH, D'Souza J, et al. Mapping barriers and intervention activities to behaviour change theory for Mobilization of Vulnerable Elders in Ontario (MOVE ON), a multi-site implementation intervention in acute care hospitals. *Implement Sci.* 2014;9:160.
19. Dermody G, Kovach CR. Barriers to Promoting Mobility in Hospitalized Older Adults. *Res Gerontol Nurs.* 2018;11(1):17-27.
20. Michie S JM, Francis J, Hardeman W, Eccles M. From Theory to Intervention: Mapping Theoretically Derived Behavioural Determinants to Behaviour Change Techniques. *Applied Psychology.* 2008 57(4):660 - 80.
21. Holst M, HPL, Pedersen LA., Paulsen S., Valentinsen C.D., Kohler M. Physical activity in hospitalized old medical patients; how active are they and what. *J Aging Res Clin Pract.* 2015;4(2):116-23.
22. Graf CL. Patient, Nurse, and Hospital Factors That Influence the Mobility of Hospitalized Older Adults [Dissertation]. San Francisco, USA: UCSF; 2013.

23. Dermody G, Kovach CR. Nurses' Experience With and Perception of Barriers to Promoting Mobility in Hospitalized Older Adults: A Descriptive Study. *J Gerontol Nurs.* 2017;43(11):22-9.
24. Doherty-King B, Bowers B. How nurses decide to ambulate hospitalized older adults: development of a conceptual model. *Gerontologist.* 2011;51(6):786-97.
25. De Klein K, Valkenet K, Veenhof C. Perspectives of patients and health-care professionals on physical activity of hospitalized patients. *Physiother Theory Pract.* 2019:1-8.
26. Lim SH, Ang SY, Ong HK, Lee TZY, Lee TXL, Luo EZ, et al. Promotion of mobility among hospitalised older adults: An exploratory study on perceptions of patients, carers and nurses. *Geriatr Nurs.* 2020;41(5):608-14.
27. Brown CJ, Williams BR, Woodby LL, Davis LL, Allman RM. Barriers to mobility during hospitalization from the perspectives of older patients and their nurses and physicians. *J Hosp Med.* 2007;2(5):305-13.
28. Gourlan M, Bernard P, Bortolon C, Romain AJ, Loreyre O, Carayol M, et al. Efficacy of theory-based interventions to promote physical activity. A meta-analysis of randomised controlled trials. *Health Psychol Rev.* 2016;10(1):50-66.
29. Atkins L, Francis J, Islam R, O'Connor D, Patey A, Ivers N, et al. A guide to using the Theoretical Domains Framework of behaviour change to investigate implementation problems. *Implement Sci.* 2017;12(1):77.
30. Craig P, Dieppe P, Macintyre S, Michie S, Nazareth I, Petticrew M. Developing and evaluating complex interventions: the new Medical Research Council guidance. *BMJ.* 2008;337:a1655.
31. McGowan LJ, Powell R, French DP. How can use of the Theoretical Domains Framework be optimized in qualitative research? A rapid systematic review. *Br J Health Psychol.* 2020;25(3):677-94.
32. Michie S, Atkins L, West R. *The Behaviour Change Wheel: A Guide to Designing Interventions.* 1st ed. United Kingdom: Silverback Publishing; 2014.
33. Nilsen P. Making sense of implementation theories, models and frameworks. *Implementation Science.* 2015;10(1):53.
34. Wood CE, Richardson M, Johnston M, Abraham C, Francis J, Hardeman W, et al. Applying the behaviour change technique (BCT) taxonomy v1: a study of coder training. *Transl Behav Med.* 2015;5(2):134-48.
35. Tong A, Sainsbury P, Craig J. Consolidated criteria for reporting qualitative research (COREQ): a 32-item checklist for interviews and focus groups. *Int J Qual Health Care.* 2007;19(6):349-57.
36. de Morton NA, Berlowitz DJ, Keating JL. A systematic review of mobility instruments and their measurement properties for older acute medical patients. *Health Qual Life Outcomes.* 2008;6:44.
37. Holden MK, Gill KM, Magliozzi MR, Nathan J, Piehl-Baker L. Clinical gait assessment in the neurologically impaired. Reliability and meaningfulness. *Phys Ther.* 1984;64(1):35-40.
38. Kalisch BJ, Lee S, Dabney BW. Outcomes of inpatient mobilization: a literature review. *J Clin Nurs.* 2014;23(11-12):1486-501.
39. Hoyer EH, Brotman DJ, Chan KS, Needham DM. Barriers to early mobility of hospitalized general medicine patients: survey development and results. *Am J Phys Med Rehabil.* 2015;94(4):304-12.
40. Cane J, O'Connor D, Michie S. Validation of the theoretical domains framework for use in behaviour change and implementation research. *Implement Sci.* 2012;7:37.
41. Weatherson KA, McKay R, Gainforth HL, Jung ME. Barriers and facilitators to the implementation of a school-based physical activity policy in Canada: application of the theoretical domains framework. *BMC Public Health.* 2017;17(1):835.
42. Garne-Dalgaard A, Mann S, Bredahl TVG, Stochkendahl MJ. Implementation strategies, and barriers and facilitators for implementation of physical activity at work: a scoping review. *Chiropr Man Therap.* 2019;27:48.
43. Quigley A, Baxter L, Keeler L, MacKay-Lyons M. Using the Theoretical Domains Framework to identify barriers and facilitators to exercise among older adults living with HIV. *AIDS Care.* 2019;31(2):163-8.
44. Haith-Cooper M, Waskett C, Montague J, Horne M. Exercise and physical activity in asylum seekers in Northern England; using the theoretical domains framework to identify barriers and facilitators. *BMC Public Health.* 2018;18(1):762.
45. Nicholson SL, Donaghy M, Johnston M, Sniehotta FF, van Wijck F, Johnston D, et al. A qualitative theory guided analysis of stroke survivors' perceived barriers and facilitators to physical activity. *Disabi Rehabil.* 2014;36(22):1857-68.

46. Hsieh HF, Shannon SE. Three approaches to qualitative content analysis. *Qual Health Res.* 2005;15(9):1277-88.
47. Hennink MM, Kaiser BN, Marconi VC. Code Saturation Versus Meaning Saturation: How Many Interviews Are Enough? *Qual Health Res.* 2017;27(4):591-608.
48. van Nes F, Abma T, Jonsson H, Deeg D. Language differences in qualitative research: is meaning lost in translation? *Eur J Ageing.* 2010;7(4):313-6.
49. Koenders N, van Oorsouw R, Seeger JPH, Nijhuis-van der Sanden MWG, van de Glind I, Hoogeboom TJ. "I'm not going to walk, just for the sake of walking...": a qualitative, phenomenological study on physical activity during hospital stay. *Disabil Rehabil.* 2020;42(1):78-85.
50. Geelen SJG, van Dijk-Huisman HC, de Bie RA, Veenhof C, Engelbert R, van der Schaaf M, et al. Barriers and enablers to physical activity in patients during hospital stay: a scoping review. *Syst Rev.* 2021;10(1):293.
51. Geelen SJG, Giele BM, Engelbert RHH, de Moree S, Veenhof C, Nollet F, et al. Barriers to and solutions for improving physical activity in adults during hospital stay: a mixed-methods study among healthcare professionals. *Disabil Rehabil.* 2021:1-10.
52. Prior M, Guerin M, Grimmer-Somers K. The effectiveness of clinical guideline implementation strategies--a synthesis of systematic review findings. *J Eval Clin Pract.* 2008;14(5):888-97.
53. Little EA, Presseau J, Eccles MP. Understanding effects in reviews of implementation interventions using the Theoretical Domains Framework. *Implement Sci.* 2015;10:90.
54. Phillips CJ, Marshall AP, Chaves NJ, Jankelowitz SK, Lin IB, Loy CT, et al. Experiences of using the Theoretical Domains Framework across diverse clinical environments: a qualitative study. *J Multidiscip Healthc.* 2015;8:139-46.
55. Baldwin CE, Phillips AC, Edney SM, Lewis LK. Recommendations for older adults' physical activity and sedentary behaviour during hospitalisation for an acute medical illness: an international Delphi study. *Int J Behav Nutr Phys Act.* 2020;17(1):69.
56. Ley L, Khaw D, Duke M, Botti M. The dose of physical activity to minimise functional decline in older general medical patients receiving 24-hr acute care: A systematic scoping review. *J Clin Nurs.* 2019;28(17-18):3049-64.
57. Scheerman K, Raaijmakers K, Otten RHJ, Meskers CGM, Maier AB. Effect of physical interventions on physical performance and physical activity in older patients during hospitalization: a systematic review. *BMC Geriatr.* 2018;18(1):288.
58. Resnick B, Boltz M. Optimizing Function and Physical Activity in Hospitalized Older Adults to Prevent Functional Decline and Falls. *Clin Geriatr Med.* 2019;35(2):237-51.

CHAPTER FOUR

DEVELOPMENT AND INTERNAL VALIDATION OF A
PREDICTION MODEL TO IDENTIFY OLDER ADULTS
AT RISK OF LOW PHYSICAL ACTIVITY LEVELS
DURING HOSPITALISATION: A PROSPECTIVE
COHORT STUDY

Hanneke C. van Dijk-Huisman
Mandy H.P. Welters
Wouter Bijmens
Sander M.J. van Kuijk
Fabienne J. H. Magdelijns
Robert A. de Bie
Antoine F. Lenssen

Published in BMC Geriatrics 2022;22:479

Digital Object Identifier: 10.1186/s12877-022-03146-9

ABSTRACT

Background

Inactive behaviour is common in older adults during hospitalisation and associated with poor health outcomes. If patients at high risk of spending little time standing/walking could be identified early after admission, they could be given interventions aimed at increasing their time spent standing/walking. This study aims to identify older adults at high risk of low physical activity (PA) levels during hospitalisation.

Methods

Prospective cohort study of 165 older adults (≥ 70 years) admitted to the department of Internal Medicine of Maastricht University Medical Centre for acute medical illness. Two prediction models were developed to predict the probability of low PA levels during hospitalisation. Time spent standing/walking per day was measured with an accelerometer until discharge (≤ 12 days). The average time standing/walking per day between inclusion and discharge was dichotomized into low/high PA levels by dividing the cohort at the median (50.0%) in model 1, and lowest tertile (33.3%) in model 2. Potential predictors - Short Physical Performance Battery (SPPB), Activity Measure for Post-Acute Care (AM-PAC), age, sex, walking aid use, and disabilities in activities of daily living - were selected based on literature and analysed using logistic regression analysis. Models were internally validated using bootstrapping. Model performance was quantified using measures of discrimination (area under the receiver operating characteristic curve (AUC)) and calibration (Hosmer and Lemeshow (H-L) goodness-of-fit test and calibration plots).

Results

Model 1 predicts a probability of spending ≤ 64.4 minutes standing/walking and holds the predictors SPPB, AM-PAC and sex. Model 2 predicts a probability of spending ≤ 47.2 minutes standing/walking and holds the predictors SPPB, AM-PAC, age and walking aid use. AUCs of models 1 and 2 were .80 (95% confidence interval (CI)=0.73-0.87) and 0.86 (95%CI=0.79-0.92), respectively, indicating good discriminative ability. Both models demonstrate near perfect calibration of the predicted probabilities and good overall performance, with model 2 performing slightly better.

Conclusions

The developed and internally validated prediction models may enable clinicians to identify older adults at high risk of low PA levels during hospitalisation. External validation and determining the clinical impact are needed before applying the models in clinical practise.

BACKGROUND

Older adults admitted to hospital with an acute medical illness show high prevalence of multimorbidity and age-related impairments, such as malnutrition, cognitive impairment, incontinence, and sensory impairment¹. Combined with their decreased physiological and functional reserve capacity, this can result in poor outcomes²⁻⁴. Moreover, older adults spent little time standing and walking during hospitalisation. On average, between 30 and 117 minutes is spent standing or walking per day, the remainder of the day is spent lying in bed or sitting in a chair⁵⁻¹².

Inactive behaviour during hospitalisation is strongly associated with functional decline^{2,12-14}, increased length of hospital stay¹³, increased risk of institutionalization^{2,5,15}, and mortality^{2,6,8,16}. The association between physical inactivity and these negative outcomes is independent of illness severity or comorbidities^{2,6,9,14,17,18}. If patients at high risk of spending little time standing and walking could be identified early after admission, they could be given targeted interventions aimed at increasing their time spend standing and walking, such as guidance from a physiotherapist. As offering such interventions may require substantial resources, we aimed to be able to identify patients that are the least active and that are likely to benefit most from increasing their PA behaviour. Identification of these patients can therewith contribute to improved patient outcomes as well as value-based healthcare.

To our knowledge, a prognostic tool that predicts a patient's probability of spending little time standing and walking during hospitalisation has not been developed yet. However, in recent years the number of studies investigating physical activity (PA) behaviour of older adults admitted to a hospital with an acute medical illness has grown and more insight has been gained in factors associated with inactive behaviour during hospitalisation^{7-10,14,19-22}. Because of the association between inactive behaviour and functional decline we expect that functional assessment tools like the Short Physical Performance Battery (SPPB) and the Activity Measure for Post-Acute Care Inpatient Basic Mobility short form (AM-PAC) could help to accurately predict the probability of spending little time standing and walking during hospitalisation for older adults. Evensen et al. supported this by showing an association between SPPB-score and time spent standing and walking in older adults acutely admitted to a geriatric ward⁹. Moreover, age^{7,19}, sex¹⁹, disabilities in activities of daily living (ADL) two weeks preceding admission^{7-10,14,19-21}, and the use of a walking aid preceding hospitalisation^{7,20,22} are also reported to be associated with patients' PA behaviour during hospitalisation. Therefore, these factors may also contribute to predictive accuracy. The aim of this study is to develop and validate a prediction model that can be used early after admission to identify older adults at high risk of spending little time standing and walking during hospitalisation.

METHODS

Study design

This single centre, prospective cohort study was conducted at the department of Internal Medicine of Maastricht University Medical Centre (MUMC+) in Maastricht, the Netherlands, between October 2018 and March 2020. The Transparent Reporting of a multivariable prediction model for Individual Prognosis or Diagnosis (TRIPOD) statement was used as reporting guideline (Additional file 1)²³.

Study population

Older adults, admitted to the department of Internal Medicine of the MUMC+ for acute care were recruited on weekdays by their attending physician and were asked for consent to be contacted by a researcher. Patients received verbal and written information about the study from the researcher within 48 hours after admittance. The researcher contacted the patients again the next day, and written informed consent was obtained before study initiation. Confidentiality of data processing and anonymity of the participant were guaranteed.

Eligible patients were included when: 70 years or older, admitted to the department of Internal Medicine with an acute medical illness, sufficient understanding of the Dutch language, living at home before hospitalisation, and able to walk independently two weeks before admission as reported on the Functional Ambulation Categories (FAC >3)^{24,25}. Exclusion criteria were: presence of contraindications to walking or wearing an accelerometer on the upper leg, mentally incapacitated subjects, inability to follow instructions due to cognitive problems or severe agitation, (re)admittance to the intensive care unit, a life expectancy of less than three months and previous participation in this study.

The following criteria were established through performing a brief screening with the attending physician prior to the informed consent procedure: age, admission for an acute medical illness, presence of contraindications to walking or wearing an accelerometer, mental incapacity, and life expectancy. Remaining criteria were checked by patient report.

Procedure

Physical activity monitoring

PA monitoring started immediately after informed consent was obtained (t_0). PA was monitored with the MOX activity monitor (MOX; Maastricht Instruments B.V., the Netherlands). The device contains a tri-axial accelerometer sensor (ADXL362;

Analog Devices, Norwood, MA, USA) in a small waterproof housing (35 × 35 × 10 mm, 11 g). Raw acceleration data (± 8 g) were measured by three orthogonal sensor axes (X, Y and Z) at a 25 Hz sampling rate. PA was measured in time spent standing/walking as this was deemed a more appropriate sensor based outcome variable for hospitalised older adults than intensity levels or step counts²⁶. The MOX activity monitor has been validated to differentiate lying/sitting from standing/walking in hospitalised patients²⁷. A trained researcher fixated the accelerometer to the anterior thigh with a hypoallergenic plaster, 10 cm proximal of the patella. PA was continuously measured and each accelerometer was replaced with a fully charged one after seven days when needed. Nurses examined the skin for irritation every day. PA monitoring ended after twelve days or at the day of discharge, whichever came first. After removal of the accelerometer, raw accelerometer data was uploaded to a computer and participation in the study ended (t_1).

A complete measurement day was defined as a 24-hour interval starting and ending at midnight. If the accelerometer was temporarily removed (e.g., MRI), days with ≥ 20 hours of wear time were included in the analysis. MATLAB (version 9.5 (R2018b) Natick, Massachusetts: The MathWorks Inc.: Natick, MA, USA; 2018) was used to calculate the number of minutes spent standing/walking per day. Subsequently, the average number of minutes spent standing/walking per day between t_0 and t_1 was calculated per patient.

For prediction model development, the average number of minutes spent standing/walking per day between t_0 and t_1 was dichotomized into low and high PA levels. Clinical guidelines stipulating the amount of time patients should to be standing/walking during hospitalisation do not exist yet^{11,21,28-31}. Guidelines for healthy elderly exist, but are not suitable for hospitalised elderly³²⁻³⁴. As it was not possible to determine the optimal cut-off value for the dichotomization of time spent standing/walking based on existing recommendations, a data-driven approach was used with norm-referenced cut-off values instead of criterion-referenced cut-off values. Norm-referenced cut-off values were based on the prevalence of low PA levels (32%-50%) in previous studies^{2,14,19,35}. To enable the comparison of models with different cut-off values, two prediction models were developed with cut-off values capturing this range. For model 1, the average number of minutes spent standing/walking per day between t_0 and t_1 was dichotomized into low and high PA levels by dividing the cohort at the median, categorizing 50.0% of the patients as having low PA levels. For development of model 2, the cohort was divided at the lowest tertile, categorizing 33.3% of the patients as having low PA levels. The use of accelerometers allowed the assessment of low or high PA levels between t_0 and t_1 to remain blinded.

Potential predictors

Potential predictors were preselected based on published studies reporting factors associated with inactive behaviour of older adults admitted to a hospital with an acute medical illness^{7-10,14,19,20}. The following six predictors were preselected: SPPB, AM-PAC, age, sex, disabilities in ADL two weeks preceding admission, and walking aid use preceding hospitalisation.

Functional mobility was assessed by the researcher immediately after PA monitoring had started, using the SPPB and AM-PAC. The SPPB is a performance based tool to measure physical performance by assessing balance, walking speed and lower extremity strength^{36,37}. It provides a total score between 0 and 12 points, with 12 points reflecting the highest level of performance.^{36,38} The SPPB has good to excellent intra-rater and inter-rater reliability, and excellent criterion validity and responsiveness. It presents a good balance between mobility, measurement properties and applicability to an acute care geriatric unit³⁶.

The AM-PAC Inpatient Basic Mobility short form assesses the following daily activities: turning in bed, sitting down and standing up, moving from lying to sitting, moving from a bed to chair, walking and climbing stairs. Climbing stairs was left out of the analysis as not every patient needs to climb stairs at home. This provided a total score between 1 and 20 points, dichotomized into dependent (≤ 19 points=0) versus independent mobility (20 points=1) based on receiver operating characteristic (ROC) curve analysis. The AM-PAC is short and easy to use. It shows large inter-rater reliability and test-retest reliability^{39,40} and has been validated for the entire hospital population⁴¹.

Disabilities in ADL two weeks preceding admission were reported on the Katz Index of Independence in Activities of Daily Living (Katz ADL) at t_0 . It rates the patient's performance of six activities (bathing, dressing, toileting, transferring, continence, feeding) on a dichotomous scale (dependent/independent)^{42,43}. The number of disabilities was dichotomized (0/ ≥ 1 disabilities) based on ROC curve analysis. Although few reliability and validity studies exist, the Katz ADL is used extensively to assess functional capabilities of older adults in clinical settings^{43,44}. Furthermore, age, sex (0=male/1=female), and walking aid use preceding hospitalisation (none, walker, cane/crutch) were assessed by patient report at t_0 .

Medical and demographic data

At t_1 , the following data was extracted from the electronic health record: clinical diagnosis of the current hospitalisation based on the ICD-11⁴⁵, number of comorbidities (Charlson Comorbidity Index), experienced falls in the last six months (0/ ≥ 1 falls), physiotherapy consulted during hospitalisation (yes/no), length of stay

in hospital (days) and discharge location (home, geriatric rehabilitation centre, nursing home, other).

Sample size

This study initially aimed to develop only one model, categorizing 50.0% of the patients as having low PA levels. Therefore, the sample size calculation was based on model 1. Post-hoc discussions regarding optimal cut-off values of low PA levels resulted in the development of a second model, enabling the comparison of different cut-off values. Six potential predictors were preselected. Because 'walking aid use preceding hospitalisation' has a categorical outcome containing three categories it had to be counted double, resulting in a sample size calculation based on seven potential predictors. It is recommended that at least 10 events should be collected per potential predictor⁴⁶. An event is defined as the outcome status 'low PA levels during hospitalisation', with an estimated event rate of 50.0%. To develop a model with seven potential predictors, at least 70 events were required, resulting in a sample size of at least 140 patients ($70/50*100$). Based on the assumption of a 15% dropout rate, 165 patients were needed in this study.

Data analysis

Data quality and missing data

Data were checked for completeness and inconsistencies. Any inconsistencies or incomplete data were corrected or completed. Missing values were imputed using stochastic regression imputation with fully conditional specification^{47,48}. To determine whether imputation led to radically different results, a sensitivity analysis was performed by comparing the outcomes of the imputed data set with the use of complete cases only.

Study population characteristics

Characteristics of patients were compared between the low and high PA level groups. To compare proportions, the chi-square test was used. For continuous variables, the independent samples t-test or Mann-Whitney U test was used for normally and not-normally distributed data, respectively. A P -value <0.05 was used to indicate statistical significance.

Model development

The models were developed using 'low PA levels during hospitalisation' as the outcome variable. Multicollinearity of potential predictor variables was checked using collinearity diagnostics (Pearson correlation coefficients, variance inflation factor (VIF) and tolerance). Additionally, continuous variables were checked for

having a linear association with the log odds of the outcome. For model 1, all seven predictors were introduced in a multivariable logistic regression model. For model 2, only five predictors could be introduced as the sample size was based on model 1 and the prevalence of low PA levels was lower in model 2. Therefore, univariable regression analysis was performed as additional step to select five potential predictors. To reduce the number of predictors in the multivariable logistic regression models, backward stepwise elimination based on the Wald test was used. A liberal P -value of 0.20 was used to prevent too early deletion of potentially relevant predictors⁴⁹.

Internal validation

The models were internally validated using bootstrapping. B -bootstrap samples of the same size as the original sample ($B=1000$ was used) were drawn with replacement from the original data, reflecting the drawing of samples from the underlying population. A shrinkage factor was estimated to adjust the model coefficients in order to make future predictions less extreme. After shrinkage, the model intercepts were re-estimated to prevent systematic under- or overestimation of risks.

Performance of the model

Overall performance of both models was assessed using Nagelkerke's R^2 and the Brier score. The ability of the models to discriminate between patients with low and high PA levels during hospitalisation was quantified as the area under the receiver operating characteristic curve (AUC). Additionally, sensitivity, specificity, positive predictive value (PPV), and negative predictive value (NPV) were calculated for a selection of probability cut-off values. To classify patients as being at high risk of low PA levels during hospitalisation, a probability threshold can be used. Patients are considered at high risk if their predicted probabilities are at or above this threshold. In order to have a low rate of patients misclassified as being at low risk (i.e. false-negative predictions), a probability threshold yielding a high NPV, but acceptable PPV, was chosen per model.

The agreement between predicted probabilities and observed frequencies of the outcome (accuracy) was assessed by visually inspecting the calibration plot. Furthermore, a Hosmer and Lemeshow (H-L) goodness-of-fit statistic was computed, with non-significant H-L statistics indicating good model fit. All statistical analyses were performed using SPSS version 23.0.0.2 (SPSS, Chicago, Ill., USA) and R version 4.0.4 (www.r-project.org).

RESULTS

Study population characteristics

Between October 2018 and March 2020, 430 older adults admitted with an acute medical illness were screened for eligibility. In total, 215 patients were identified as eligible and 165 patients were included in this study. Of the included patients, 19 (12%) dropped out and data of 146 patients was used in the analysis (Figure 4.1 TRIPOD flow chart).

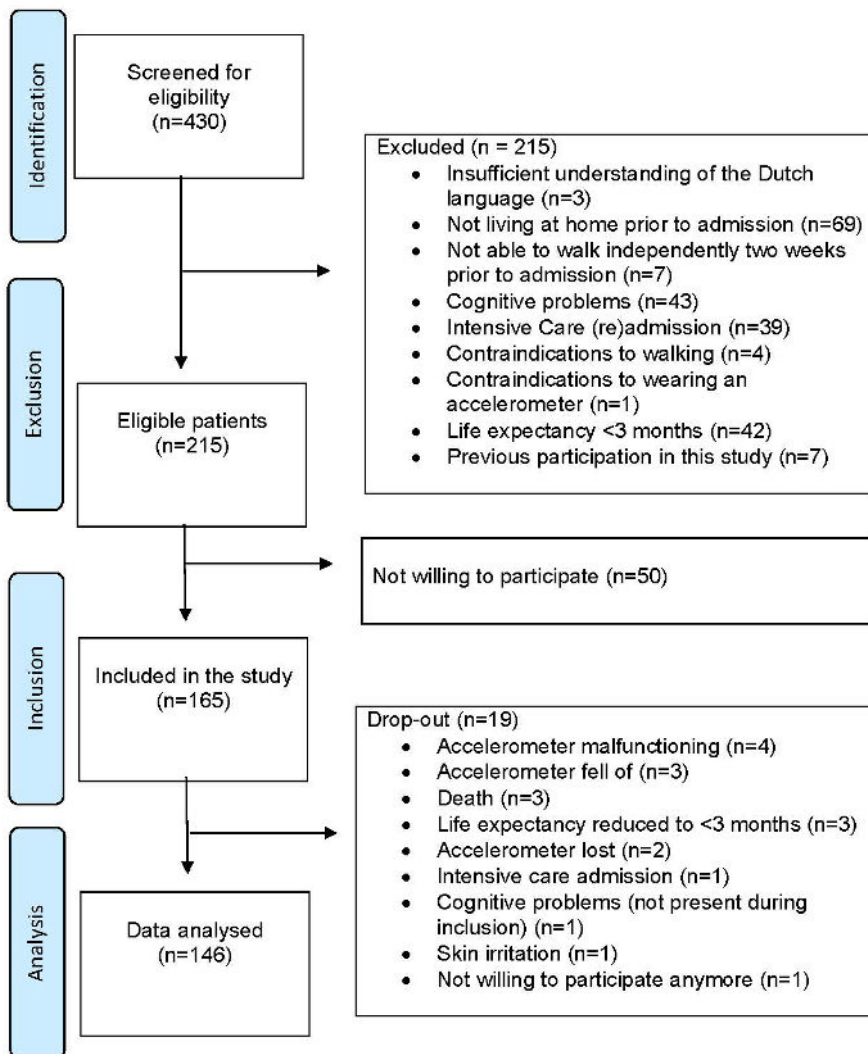

Figure 4.1 TRIPOD flow chart.

Of these 146 patients, the mean age (\pm standard deviation (SD)) was 81.3 (6.8) years and 86 (58.9%) patients were male. The group of patients were median (\pm Interquartile Range (IQR)) 64.4 (34.8 – 100.1) minutes standing/walking per day and 33.3% of the patients were \leq 47.2 minutes standing/walking per day. The characteristics of study participants are reported in Table 4.1.

Table 4.1 Characteristics of study participants.

Variable	Model 1			<i>P</i> -value*	Model 2		
	All patients (n=146)	Low PA level (n=73)	High PA level (n=73)		Low PA level (n=49)	High PA Level (n=97)	<i>P</i> -value*
Age, years (mean, SD)	81.3 (6.8)	82.4 (6.6)	80.2 (6.9)	.896	82.0 (6.8)	81.0 (6.8)	.363
Sex (<i>n</i> , %)				.737			.169
Female	60 (41.1%)	29 (39.7%)	31 (42.5%)		24 (49.0%)	36 (37.1%)	
Average min. standing /walking per day (median, IQR)	64.4 (34.7–100.1)	34.8 (16.9–51.8)	98.7 (78.12–136.6)	<.001	24.4 (9.2–35.5)	84.6 (64.4–124.9)	<.001
SPPB (median, IQR)	4 (2–8)	3 (1–5)	7 (4–10)	<.001	2 (0–3)	6 (4–10)	<.001
AM-PAC (<i>n</i> , %)				<.001			<.001
\leq 19	57 (39.0%)	44 (60.3%)	13 (17.8%)		36 (73.5%)	21 (21.6%)	
20	89 (61.0%)	29 (39.7%)	60 (82.2%)		13 (26.5%)	76 (78.4%)	
Katz ADL (<i>n</i> , %)				.045			<.001
0 disabilities	82 (56.2%)	35 (47.9%)	47 (64.4%)		17 (34.7%)	65 (67.0%)	
\geq 1 disabilities	64 (43.8%)	38 (52.1%)	26 (35.6%)		32 (65.3%)	32 (33.0%)	
Walking aid (<i>n</i> , %)				.038			.001
None	79 (54.1%)	32 (43.8%)	47 (64.4%)		16 (32.7%)	63 (64.9%)	
Walker	49 (33.6%)	31 (42.5%)	18 (24.7%)		26 (53.1%)	23 (23.7%)	
Crutch or cane	18 (12.3%)	10 (13.7%)	8 (11.0%)		7 (14.3%)	11 (11.3%)	
Clinical diagnosis (<i>n</i> , %)				.065			.120
Digestive	35 (24.0%)	15 (20.5%)	20 (27.4%)		9 (18.4%)	26 (26.8%)	
Respiratory	27 (18.5%)	10 (13.7%)	17 (23.3%)		7 (14.3%)	20 (20.6%)	
Infectious	23 (15.8%)	17 (23.3%)	6 (8.2%)		13 (26.5%)	10 (10.3%)	
Neoplasms	16 (11.0%)	10 (13.7%)	6 (8.2%)		7 (14.3%)	9 (9.3%)	
Genitourinary	14 (9.6%)	9 (12.3%)	5 (6.8%)		3 (6.1%)	11 (11.3%)	
Circulatory	7 (4.8%)	2 (2.7%)	5 (6.8%)		1 (2.0%)	6 (6.2%)	
Other	24 (16.4%)	10 (13.7%)	14 (19.2%)		9 (18.4%)	15 (15.5%)	
Comorbidities (CCI) (median, IQR)	2 (1–4)	3 (1–4)	2 (1–3)	.064	3 (1.5–5)	2 (1–3)	.001
Nr. of falls \leq 6 months (median, IQR)	0 (0–1)	0 (0–2)	0 (0–1)	.386	0 (0–2)	0 (0–1)	.086
PT consulted (<i>n</i> , %)				<.001			<.001
Yes	89 (61.0%)	55 (75.3%)	34 (46.6%)		40 (81.6%)	49 (50.5%)	
No	57 (39.0%)	18 (24.7%)	39 (53.4%)		9 (18.4%)	48 (49.5%)	
LOS, days (median, IQR)	9 (6–13)	11 (7–15)	8 (6 – 11)	.001	13 (8 – 17)	8 (6 – 11)	<.001

Table 4.1 (continued)

Variable	Model 1			<i>P</i> -value*	Model 2		<i>P</i> -value*
	All patients (n=146)	Low PA level (n=73)	High PA level (n=73)		Low PA level (n=49)	High PA level (n=97)	
Discharge location (<i>n</i> , %)				.001			<.001
Home	119 (81.5%)	50 (68.5%)	69 (94.5%)		29 (59.2%)	90 (92.8%)	
Geriatric rehabilitation centre	16 (11.0%)	13 (17.8%)	3 (4.1%)		12 (24.5%)	4 (4.1%)	
Nursing home	6 (4.1%)	5 (6.8%)	1 (1.4%)		3 (6.1%)	3 (3.1%)	
Other	5 (3.4%)	5 (6.8%)	0 (0.0%)		5 (10.2%)	0 (0.0%)	

Characteristics of study participants (older adults hospitalised with an acute medical illness) categorized by low or high PA levels, with cut-off values of 64.4 and 47.2 minutes standing/walking in model 1 and 2, respectively. PA=Physical Activity, SD=standard deviation, IQR=Interquartile Range, SPPB=Short Physical Performance Battery, AM-PAC=Activity Measure for Post-Acute Care Inpatient Basic Mobility short form, Katz ADL=Katz Index of Independence in Activities of Daily Living, CCI=Charlson Comorbidity Index, PT=physiotherapy, LOS=length of hospital stay.

* *P*-value <0.05. To compare proportions, the chi-square test was used. For continuous variables, the independent sample t-test or Mann-Whitney U test were used for normally and not-normally distributed data, respectively.

Model development and internal validation

In the dependent variable ‘number of minutes spent standing/walking per day’, data was missing for 72 out of 949 measurement days (7.5%), spread over 27 patients (18%). Main reasons for missing values were the accelerometer falling off, getting lost or malfunctioning. Data of all other variables was complete. After imputation, data of all 146 patients was complete for development of the prediction model.

For development of model 1, all predictors were entered in the multivariable regression model (SPPB, AM-PAC, age, sex, disabilities in ADL, and walking aid use). For development of model 2, univariable regression analysis was first performed on all potential predictors, after which SPPB, AM-PAC, age, and walking aid use preceding hospitalisation were entered in the multivariable regression model. Table 4.2 shows the original and internally validated models that can be used to compute the probability of low PA levels during hospitalisation. Internal validation yielded a shrinkage factor of 0.95 and 0.90 in model 1 and 2, respectively. The equations in Table 4.2 can be used to compute the individual probability of low PA levels during hospitalisation.

Table 4.2 Regression coefficients and odds ratios with 95% CI from the original and internally validated models.

Variable	Original Model		Model after internal validation	
	Regression coefficient	Odds Ratio (95% CI)	P-value	Regression coefficient ^a
Model 1 - Cut-off value for low or high PA levels at 50.0% of the cohort (64.4 minutes standing/walking)				
Intercept	2.042	-	.000	1.942
SPPB	-.251	.778 (.677-.894)	.000	-.239
AM-PAC (independent)	-.894	.409 (.159-1.054)	.064	-.850
Sex (female)	-.519	.595 (.269-1.313)	.199	-.493
Model 2 - Cut-off value for low or high PA levels at 33.3% of the cohort (47.2 minutes standing/walking)				
Intercept	7.008	-	.022	6.255
SPPB	-.305	.737 (.608-.894)	.002	-.275
AM-PAC (independent)	-1.124	.325 (.115-.921)	.034	-1.012
Age	-.078	.925 (.861-.994)	.034	-.070
Walking aid				
Crutch/Cane	-.006	.994 (.248-3.977)	.993	-.006
Walker	1.281	3.601 (1.317-9.843)	.013	1.153

To estimate the individual probability of low PA levels during hospitalisation:

$$\text{Model 1: } P_{(\text{Low PA})} = 1 / (1 + e^{-(1.942 - .239 \cdot \text{SPPB} - .850 \cdot \text{AM-PAC} - .493 \cdot \text{Female})}) * 100\%$$

$$\text{Model 2: } P_{(\text{Low PA})} = 1 / (1 + e^{-(6.255 - .275 \cdot \text{SPPB} - 1.012 \cdot \text{AM-PAC} - .070 \cdot \text{Age} - .006 \cdot \text{Crutch/Cane} + 1.153 \cdot \text{Walker})}) * 100\%$$

CI=confidence interval, PA=Physical Activity, SPPB=Short Physical Performance Battery, AM-PAC=Activity Measure for Post-Acute Care Inpatient Basic Mobility short form.

^a Regression coefficients after adjustment for overfitting by shrinkage (shrinkage factor model 1 = 0.95 and model 2 = 0.90); the intercept was re-estimated.

Performance of the models

All model performance measures are shown in detail in Additional file 2. The AUCs of model 1 and 2 were 0.80 (95% confidence interval (CI)=0.73-0.87) and 0.86 (95%CI=0.79-0.92), respectively, indicating good discriminatory ability. The optimism-corrected AUCs were 0.79 and 0.84 for model 1 and 2, respectively. Figure 4.2 shows the ROC curves of both models. Both models show good calibration, as indicated by calibration plots showing good agreement between actual and predicted probabilities (Additional file 3). Additionally, both H-L goodness-of-fit tests were non-significant ($P=0.755$ and $P=0.209$). Overall, model 2 showed a slightly better performance.

A selection of probability cut-off values and their corresponding sensitivity, specificity, PPV and NPV are reported in Additional file 4 and Additional file 5. Probability thresholds of 0.41 and 0.30 were chosen for model 1 and 2, respectively. The corresponding classification tables are shown in Figure 4.3.

The sensitivity analyses showed similar results for the imputed and the original non-imputed data sets and we conclude that imputation did not result in large differences.

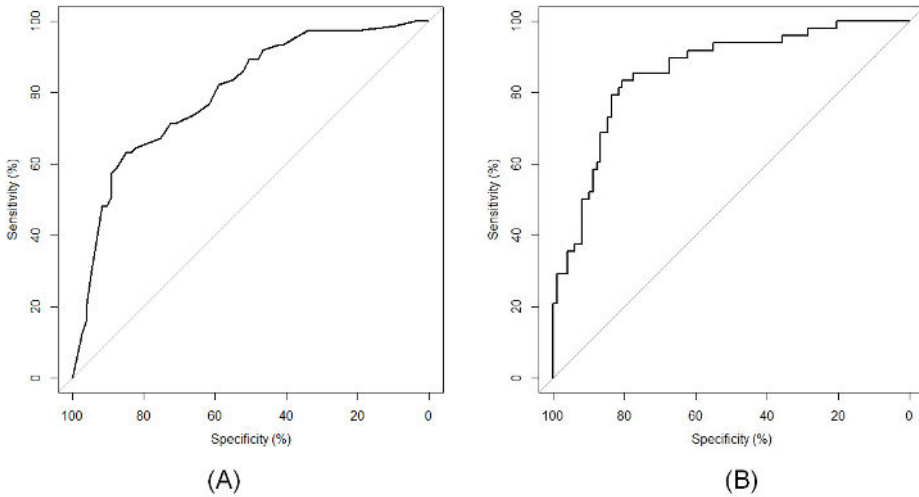

Figure 4.2 Receiver operating characteristic curve of (A) model 1 (AUC .80 (95% confidence interval (CI)=0.73-0.87)), and (B) model 2 (AUC .86 (95%CI=0.79-0.92)).

		Model 1 Actual PA				Model 2 Actual PA				
		Low PA	High PA			Low PA	High PA			
Predicted PA	Low PA	60 (TP)	30 (FP)	PPV 66.7%	NPV 76.8%	Low PA	41 (TP)	22 (FP)	PPV 65.1%	NPV 91.6%
	High PA	13 (FN)	43 (TN)				High PA	7 (FN)		
		Sensitivity 82.2%	Specificity 58.9%			Sensitivity 85.4%	Specificity 77.6%			

Figure 4.3 Classification tables showing the actual and predicted number of patients with low or high PA levels during hospitalisation and their corresponding sensitivity, specificity, PPV and NPV, using (A) model 1 (probability threshold .41) and (B) model 2 (probability threshold .30). PA=Physical Activity, TP=True Positive, FP=False Positive, FN=False Negative, TN=True Negative, PPV=Positive Predictive Value, NPV=Negative Predictive Value.

DISCUSSION

In this study we developed and internally validated two prediction models that can be used to predict the probability of low PA levels during hospitalisation for older adults admitted to a hospital with an acute medical illness. The first model predicts a patient’s probability of spending less than an average of 64.4 minutes standing/walking per day and holds three predictors: SPPB, AM-PAC and sex. The

second model predicts a patient's probability of spending less than an average of 47.2 minutes standing/walking per day and holds four predictors: SPPB, AM-PAC, age and walking aid use preceding hospitalisation. Both models showed good discriminative ability and accurate prediction of spending little time standing/walking during hospitalisation, with the second model performing slightly better.

To our knowledge, this is the first study that aims to identify older adults at high risk of spending little time standing/walking during hospitalisation. One of the challenges in developing a suitable prediction model was the lack of criterion-referenced cut-off values regarding the classification of low or high PA levels^{11,21,28-31}. Although many studies have shown that PA contributes to the prevention of negative outcomes, the optimal-dose response relationship remains unknown. Baldwin et al. provided the first international consensus for recommendations on PA and sedentary behaviour for older adults hospitalised with an acute medical illness. They recommend that older adults should: be as physically active as their abilities and condition allow; minimise time spent sedentary for extended periods; and, move more and sit less throughout the day. Additionally, muscle strengthening and balance exercises are also advised²⁹. Although this provides some guidance, criterion-referenced cut-off values regarding the classification of low and high PA levels are still lacking^{11,21,28-31}. Therefore, the current prediction models were developed using a data-driven approach with norm-referenced cut-off values capturing the range of low PA levels identified in previous studies^{2,14,19,35}. We do not know whether the resulting cut-off values of 64.4 or 47.2 minutes standing/walking are sufficient to prevent the negative effects of inactivity. This may also be influenced by many individual factors such as preadmission status, illness severity or daily caloric intake, necessitating more personalised recommendations. However, as the PA behaviour of older adults admitted for acute illness was heterogeneous in previous literature, we aimed to be able to identify patients that are the least active. As offering interventions (e.g., monitoring patients' PA behaviour using wearables) may require substantial financial resources, the prediction models allow to identify patients that are likely to benefit most from such interventions. Although criterion-referenced cut-off values are lacking, the chosen cut-off values are relevant and contribute to providing value-based healthcare.

PA was measured in time spent in different activities (lying/sitting, standing/walking), as this was deemed a more meaningful sensor based outcome variable for hospitalised older adults than intensity levels (activity counts) or step counts²⁶. First, the intensity of PA as perceived by patients may deviate from the intensity measured by the accelerometer. When patients are feeling ill they may perceive walking at low walking speeds as a high intensity activity, while the accelerometer objectively classifies this as a low intensity activity. Second, recovery or

deterioration during the admission period may result in fluctuations in perceived intensity within patients. Third, many older adults admitted to hospital with an acute medical illness require a walking aid. Moreover, slow and impaired gaits are common⁵⁰. Several studies have shown that these factors decrease the validity of activity trackers to measure step counts⁵¹⁻⁵⁴. Lastly, movements of the arms or legs performed in bed or on a chair may result in an overestimation of step count. Therefore, time spent in different activities is deemed the most appropriate sensor-based outcome measure²⁶.

The developed models show that functional assessments combined with easily acquired clinical parameters have potential to identify patients at high risk of low PA levels during hospitalisation. As we felt it important that patients at high risk would not miss out on an intervention, we opted for models with low rates of false-negative predictions. In choosing a probability threshold for each model we therefore aimed for a high NPV and accepted a higher rate of false-positive predictions.

Using model 1 with a probability threshold of 0.41 resulted in misclassification of 8.9% of all patients as being at low risk of spending less than 64.4 minutes standing/walking (false-negative predictions). Moreover, 20.6% were misclassified as being at high risk (false-positive predictions) and would be given an intervention while actually having high PA levels. The predictive abilities of model 2 are slightly better, resulting in less misclassifications. Using model 2 with a probability threshold of 0.30 will result in a 4.8% false-negative prediction rate and a 15.1% false-positive prediction rate of spending less than 47.2 minutes standing/walking.

However, a certain level of misclassifications seems inevitable when predicting the PA behaviour of hospitalised patients early after admission. Previous studies have shown that the PA behaviour of hospitalised patients is influenced by many different factors, such as complications or symptoms developing throughout the hospital stay, patient motivation, using medical devices that limit walking (e.g., IV-poles, urinary catheters, lack of portable oxygen), referral to physiotherapy, or a lack of availability of healthcare staff to provide assistance during walking⁵⁵⁻⁶¹. As some of these factors are unknown yet early after admission, they cannot be included in the models as predictors and may therefore contribute to misclassifications.

In retrospect, we consider the rate of misclassifications of both models acceptable for use in clinical practice. Although performance of model 2 was slightly better, the choice for either one of the models depends on whether roughly one hour or three quarters of an hour standing/walking are preferred as cut-off value for low PA levels during hospitalisation. Moreover, it also depends on the availability of

resources, as model 1 will classify more patients as being at high risk of low PA levels.

STRENGTHS AND LIMITATIONS

The present study has several strengths, including a prospective data collection, recruitment of consecutive patients, and inclusion of patients with mild cognitive impairments. Moreover, all predictors were selected from literature based on previous evidence^{7-10,14,19,20} while the methodology of this study followed the TRIPOD guideline for prediction modelling²³. We corrected for missing data, performed a sensitivity analysis and an internal validation procedure of the developed models.

We also recognise several limitations. First, with the current study design we cannot determine if patients changed their time spent standing/walking due to potential confounding factors that were unknown early after admission, such as receiving physiotherapy guidance or complications which may have developed during hospital stay. Second, we initially aimed to develop one prediction model. Due to post-hoc discussions regarding an optimal cut-off value we decided to develop a second model as well, enabling the comparison of different cut-off values. The power calculation was originally meant for model 1, allowing for seven potential predictors and an event rate of 50.0%. Because the event rate of model 2 was 33.3%, only five potential predictors could be introduced in the analysis. To prevent overfitting of the model by introducing too many predictors, univariable analysis had to be performed as an additional step. Third, we dichotomized the categorical AM-PAC and Katz ADL outcomes to improve the clinical applicability, which may have led to loss of information. Lastly, the algorithm of the MOX activity monitor is unable to differentiate time spent standing from time spent walking. This limited the development of a prediction model that can be used to identify older adults at high risk of spending little time walking during hospitalisation.

CLINICAL IMPLICATIONS AND RECOMMENDATIONS FOR FUTURE RESEARCH

The developed prediction models can be used in clinical practice by performing a simple screening early after admission, consisting of two functional assessments combined with self-reported information. The prediction models can be adapted into an easy-to-use calculator that can be used during screening. Using the prediction models to identify patients at high risk of low PA levels early after admission is an important first step in preventing the negative effects associated with spending little time standing/walking during hospitalisation. Patients at high

risk can subsequently be given interventions aimed at increasing their time spend standing/walking. However, as few studies have investigated the efficacy of interventions aimed at increasing the PA behaviour of older adults during hospitalisation, further research is advised, comparing different types of interventions and with detailed reporting of frequency, intensity and duration^{4,29-31}. Moreover, the accelerometer algorithm used in the current study was not able to differentiate standing from walking. Therefore, we recommend future studies to develop a prediction model using an optimised accelerometer algorithm that allows to differentiate between standing and walking in hospitalised patients. Furthermore, the current study included seven potential predictors that were associated with low PA levels of older adults admitted to hospital with an acute medical illness. However, the PA behaviour of hospitalised older adults may be influenced by many other factors as well, such as 'reason for hospitalisation' or 'history of falls'^{7,20-22,55-61}. In order to improve the prediction of older adults at risk of low PA levels, we recommend that this study should be followed by a larger study that allows to include more potential predictor variables. Lastly, before implementing the prediction models into clinical practice, future research should also focus on assessing the next steps within prediction modelling: determining the external validity and clinical impact of the models. Because this has not been performed yet in the current study, our results should be interpreted with caution. In order to choose a cut-off value for low PA levels during hospitalisation based on empirical evidence, future research should also focus on developing guidelines regarding the recommended PA levels of older adults admitted to a hospital with an acute medical illness.

CONCLUSIONS

We developed and internally validated two prediction models that can be used to predict the probability of low PA levels during hospitalisation for older adults admitted to a hospital with an acute medical illness. Both models showed a good overall performance, with a good discriminative ability and accurate prediction of low PA levels. This study showed that both models hold promise as prediction tools that enable clinicians to accurately identify older adults at high risk of low PA levels during hospitalisation.

SUPPLEMENTARY INFORMATION

Additional file 1 to 4 can be found online: <https://doi.org/10.1186/s12877-022-03146-9>.

ACKNOWLEDGEMENTS

We would like to thank all physiotherapists, nurses and physicians working at the department of Internal Medicine of the MUMC+ for their assistance in this study. We would also like to thank Bo Brans-Brabant, Anouk Weemaes and Marissa Gerards for their assistance in the data collection.

REFERENCES

1. Buurman BM HJ, de Haan RJ, Abu-Hanna A, Lagaay AM, Verhaar HJ, et al. . Geriatric conditions in acutely hospitalized older patients: prevalence and one-year survival and functional decline. *PLoS One*. 2011;6(11):e26951.
2. Brown CJ, Friedkin RJ, Inouye SK. Prevalence and outcomes of low mobility in hospitalized older patients. *J Am Geriatr Soc*. 2004;52(8):1263-70.
3. Boyd CM, Landefeld CS, Counsell SR, Palmer RM, Fortinsky RH, Kresevic D, et al. Recovery of activities of daily living in older adults after hospitalization for acute medical illness. *J Am Geriatr Soc*. 2008; 56(12):2171-9.
4. Scheerman K, Raaijmakers K, Otten RHJ, Meskers CGM, Maier AB. Effect of physical interventions on physical performance and physical activity in older patients during hospitalization: a systematic review. *BMC Geriatr*. 2018;18(1):288.
5. Brown CJ, Redden DT, Flood KL, Allman RM. The underrecognized epidemic of low mobility during hospitalization of older adults. *J Am Geriatr Soc*. 2009;57(9):1660-5.
6. Ostir GV, Berges IM, Kuo YF, Goodwin JS, Fisher SR, Guralnik JM. Mobility activity and its value as a prognostic indicator of survival in hospitalized older adults. *J Am Geriatr Soc*. 2013;61(4):551-7.
7. Fisher SR, Goodwin JS, Protas EJ, Kuo YF, Graham JE, Ottenbacher KJ, et al. Ambulatory activity of older adults hospitalized with acute medical illness. *J Am Geriatr Soc*. 2011;59(1):91-5.
8. Pedersen MM, Bodilsen AC, Petersen J, Beyer N, Andersen O, Lawson-Smith L, et al. Twenty-four-hour mobility during acute hospitalization in older medical patients. *J Gerontol A Biol Sci Med Sci*. 2013;68(3):331-7.
9. Evensen S, Sletvold O, Lydersen S, Taraldsen K. Physical activity among hospitalized older adults - an observational study. *BMC Geriatr*. 2017;17(1):110.
10. Villumsen M, Jorgensen MG, Andreassen J, Rathleff MS, Molgaard CM. Very Low Levels of Physical Activity in Older Patients During Hospitalization at an Acute Geriatric Ward: A Prospective Cohort Study. *J Aging Phys Activity*. 2015;23(4):542-9.
11. Hartley P, DeWitt AL, Forsyth F, Romero-Ortuno R, Deaton C. Predictors of physical activity in older adults early in an emergency hospital admission: a prospective cohort study. *BMC Geriatr*. 2020;20(1):177.
12. Pavon JM, Sloane RJ, Pieper CF, Colón-Emeric CS, Cohen HJ, Gallagher D, et al. Accelerometer-Measured Hospital Physical Activity and Hospital-Acquired Disability in Older Adults. *J Am Geriatr Soc*. 2020;68(2):261-5.
13. Covinsky KE, Pierluissi E, Johnston CB. Hospitalization-associated disability: "She was probably able to ambulate, but I'm not sure". *JAMA*. 2011;306(16):1782-93.
14. Zisberg A, Shadmi E, Sinoff G, Gur-Yaish N, Sruлович E, Admi H. Low mobility during hospitalization and functional decline in older adults. *J Am Geriatr Soc*. 2011;59(2):266-73.
15. Mahoney JE, Sager MA, Jalaluddin M. Use of an ambulation assistive device predicts functional decline associated with hospitalization. *J Gerontol A Biol Sci Med Sci*. 1999;54(2):M83-8.
16. Covinsky KE, Palmer RM, Fortinsky RH, Counsell SR, Stewart AL, Kresevic D, et al. Loss of independence in activities of daily living in older adults hospitalized with medical illnesses: increased vulnerability with age. *J Am Geriatr Soc*. 2003;51(4):451-8.
17. McCullagh R, Dillon C, Dahly D, Horgan NF, Timmons S. Walking in hospital is associated with a shorter length of stay in older medical inpatients. *Physiol Meas*. 2016;37(10):1872-84.
18. Fisher SR, Graham JE, Ottenbacher KJ, Deer R, Ostir GV. Inpatient Walking Activity to Predict Readmission in Older Adults. *Arch Phys Med Rehabil*. 2016;97(9 Suppl):S226-31.
19. Zisberg A, Syn-Hershko A. Factors related to the mobility of hospitalized older adults: A prospective cohort study. *Geriatr Nurs*. 2016;37(2):96-100.
20. Fisher SR, Graham JE, Brown CJ, Galloway RV, Ottenbacher KJ, Allman RM, et al. Factors that differentiate level of ambulation in hospitalised older adults. *Age Ageing*. 2012;41(1):107-11.
21. Tasheva P, Kraege V, Vollenweider P, Roulet G, Méan M, Marques-Vidal P. Accelerometry assessed physical activity of older adults hospitalized with acute medical illness - an observational study. *BMC Geriatr*. 2020;20(1):382.

22. Tasheva P, Vollenweider P, Kraege V, Roulet G, Lamy O, Marques-Vidal P, et al. Association Between Physical Activity Levels in the Hospital Setting and Hospital-Acquired Functional Decline in Elderly Patients. *JAMA Netw Open*. 2020;3(1):e1920185.
23. Collins GS, Reitsma JB, Altman DG, Moons KG. Transparent reporting of a multivariable prediction model for individual prognosis or diagnosis (TRIPOD): the TRIPOD statement. *BMJ*. 2015;350:g7594.
24. de Morton NA, Berlowitz DJ, Keating JL. A systematic review of mobility instruments and their measurement properties for older acute medical patients. *Health Qual Life Outcomes*. 2008;6:44.
25. Holden MK, Gill KM, Magliozzi MR, Nathan J, Piehl-Baker L. Clinical gait assessment in the neurologically impaired. Reliability and meaningfulness. *Phys Ther*. 1984;64(1):35-40.
26. van Dijk-Huisman HC, Weemaes ATR, Boymans T, Lenssen AF, de Bie RA. Smartphone App with an Accelerometer Enhances Patients' Physical Activity Following Elective Orthopedic Surgery: A Pilot Study. *Sensors (Basel, Switzerland)*. 2020;20(15).
27. Bastings SJL. Klinische validatie van de MOX en algoritme voor activiteitenmonitoring bij orthopedische en oncologische patiënten tijdens postoperatieve ligduur. Heerlen, the Netherlands: Zuyd Hogeschool; 2017.
28. Baldwin C, van Kessel G, Phillips A, Johnston K. Accelerometry Shows Inpatients With Acute Medical or Surgical Conditions Spend Little Time Upright and Are Highly Sedentary: Systematic Review. *Phys Ther*. 2017;97(11):1044-65.
29. Baldwin CE, Phillips AC, Edney SM, Lewis LK. Recommendations for older adults' physical activity and sedentary behaviour during hospitalisation for an acute medical illness: an international Delphi study. *Int J Behav Nutr Phys Act*. 2020;17(1):69.
30. Ley L, Khaw D, Duke M, Botti M. The dose of physical activity to minimise functional decline in older general medical patients receiving 24-hr acute care: A systematic scoping review. *J Clin Nurs*. 2019;28(17-18):3049-64.
31. Resnick B, Boltz M. Optimizing Function and Physical Activity in Hospitalized Older Adults to Prevent Functional Decline and Falls. *Clin Geriatr Med*. 2019;35(2):237-51.
32. Gezondheidsraad. Beweegrichtlijnen 2017. In: Volksgezondheid WeS, editor. Den Haag: Gezondheidsraad; 2017.
33. Bull FC, Al-Ansari SS, Biddle S, Borodulin K, Buman MP, Cardon G, et al. World Health Organization 2020 guidelines on physical activity and sedentary behaviour. *Br J Sports Med*. 2020;54(24):1451-62.
34. WHO Guidelines Approved by the Guidelines Review Committee. WHO Guidelines on Physical Activity and Sedentary Behaviour. Geneva: World Health Organization © World Health Organization 2020; 2020.
35. Agmon M, Zisberg A, Gil E, Rand D, Gur-Yaish N, Azriel M. Association Between 900 Steps a Day and Functional Decline in Older Hospitalized Patients. *JAMA int Med*. 2017;177(2):272-4.
36. Soares Menezes KVR, Auger C, de Souza Menezes WR, Guerra RO. Instruments to evaluate mobility capacity of older adults during hospitalization: A systematic review. *Arch Gerontol Geriatr*. 2017;72: 67-79.
37. Guralnik JM, Simonsick EM, Ferrucci L, Glynn RJ, Berkman LF, Blazer DG, et al. A short physical performance battery assessing lower extremity function: association with self-reported disability and prediction of mortality and nursing home admission. *J Gerontol*. 1994;49(2):M85-94.
38. McCullagh R, O'Connell E, O'Meara S, Perry I, Fitzgerald A, O'Connor K, et al. A study protocol of a randomised controlled trial to measure the effects of an augmented prescribed exercise programme (APEP) for frail older medical patients in the acute setting. *BMC Geriatr*. 2016;16:79.
39. Jette DU, Stilphen M, Ranganathan VK, Passek S, Frost FS, Jette AM. Interrater Reliability of AM-PAC "6-Clicks" Basic Mobility and Daily Activity Short Forms. *Phys Ther*. 2015;95(5):758-66.
40. Hoyer EH, Young DL, Klein LM, Kreif J, Shumock K, Hiser S, et al. Toward a Common Language for Measuring Patient Mobility in the Hospital: Reliability and Construct Validity of Interprofessional Mobility Measures. *Phys Ther*. 2018;98(2):133-42.
41. Jette DU, Stilphen M, Ranganathan VK, Passek SD, Frost FS, Jette AM. Validity of the AM-PAC "6-Clicks" inpatient daily activity and basic mobility short forms. *Phys Ther*. 2014;94(3):379-91.
42. Katz S, Ford AB, Moskowitz RW, Jackson BA, Jaffe MW. Studies of illness in the aged. The index of ADL: A standardized measure of biological and psychosocial function. *JAMA*. 1963;185:914-9.
43. Liebrecht D, King B, Bratzke L. Measurement of function in older adults transitioning from hospital to home: an integrative review. *Geriatr Nurs*. 2018;39(3):336-43.

44. Hartigan I. A comparative review of the Katz ADL and the Barthel Index in assessing the activities of daily living of older people. *Int J Older People Nursing*. 2007;2(3):204-12.
45. Organization WH. International Classification of Diseases for Mortality and Morbidity Statistics (11th Revision) 2019 [11:[Available from: <https://icd.who.int/browse11/l-m/en#/http://id.who.int/icd/entity/2136808878>].
46. Peduzzi P, Concato J, Kemper E, Holford TR, Feinstein AR. A simulation study of the number of events per variable in logistic regression analysis. *J Clin Epidemiol*. 1996;49(12):1373-9.
47. Donders AR, van der Heijden GJ, Stijnen T, Moons KG. Review: a gentle introduction to imputation of missing values. *J Clin Epidemiol*. 2006;59(10):1087-91.
48. Steyerberg EW. *Clinical Prediction Models*. 1 ed. New York, NY: Springer; 2009.
49. Harrell F. *Regression Modeling Strategies*. New York, NY: Springer; 2001.
50. Peel NM, Kuys SS, Klein K. Gait speed as a measure in geriatric assessment in clinical settings: a systematic review. *J Gerontol A, Biol Sci Med Sci*. 2013;68(1):39-46.
51. Floegel TA, Florez-Pregonero A, Hekler EB, Buman MP. Validation of Consumer-Based Hip and Wrist Activity Monitors in Older Adults With Varied Ambulatory Abilities. *J Gerontol A, Biol Sci Med Sci*. 2017;72(2):229-36.
52. Beevi FH, Miranda J, Pedersen CF, Wagner S. An Evaluation of Commercial Pedometers for Monitoring Slow Walking Speed Populations. *Telemed J E Health*. 2016;22(5):441-9.
53. Martin JB, Krč KM, Mitchell EA, Eng JJ, Noble JW. Pedometer accuracy in slow walking older adults. *Int J Ther Rehabil*. 2012;19(7):387-93.
54. Cyarto EV, Myers A, Tudor-Locke C. Pedometer accuracy in nursing home and community-dwelling older adults. *Med Sci Sports Exerc*. 2004;36(2):205-9.
55. So C, Pierluissi E. Attitudes and expectations regarding exercise in the hospital of hospitalized older adults: a qualitative study. *J Am Geriatr Soc*. 2012;60(4):713-8.
56. Brown CJ, Williams BR, Woodby LL, Davis LL, Allman RM. Barriers to mobility during hospitalization from the perspectives of older patients and their nurses and physicians. *J Hosp Med*. 2007;2(5):305-13.
57. Boltz M, Capezuti E, Shabbat N. Nursing staff perceptions of physical function in hospitalized older adults. *Appl Nurs Res*. 2011;24(4):215-22.
58. Doherty-King B, Bowers B. How nurses decide to ambulate hospitalized older adults: development of a conceptual model. *Gerontologist*. 2011;51(6):786-97.
59. Moore JE, Mascarenhas A, Marquez C, Almaawiy U, Chan WH, D'Souza J, et al. Mapping barriers and intervention activities to behaviour change theory for Mobilization of Vulnerable Elders in Ontario (MOVE ON), a multi-site implementation intervention in acute care hospitals. *Implement Sci*. 2014;9:160.
60. Boltz M, Capezuti E, Shabbat N, Hall K. Going home better not worse: older adults' views on physical function during hospitalization. *Int J Nurs Pract*. 2010;16(4):381-8.
61. Koenders N, van Oorsouw R, Seeger JPH, Nijhuis-van der Sanden MWG, van de Glind I, Hoogeboom TJ. "I'm not going to walk, just for the sake of walking...": a qualitative, phenomenological study on physical activity during hospital stay. *Disabil Rehabil*. 2020;42(1):78-85.

CHAPTER FIVE

SMARTPHONE APP WITH AN ACCELEROMETER
ENHANCES PATIENTS' PHYSICAL ACTIVITY
FOLLOWING ELECTIVE ORTHOPEDIC SURGERY:
A PILOT STUDY

Hanneke C. van Dijk-Huisman
Anouk T.R. Weemaes
Tim A.E.J. Boymans
Antoine F. Lenssen
Robert A. de Bie

Published in Sensors 2020;20:4317

Digital Object Identifier: 10.3390/s20154317

ABSTRACT

Background

Low physical activity (PA) levels are common in hospitalized patients. Digital health tools could be valuable in preventing the negative effects of inactivity. We therefore developed Hospital Fit; which is a smartphone application with an accelerometer, designed for hospitalized patients. It enables objective activity monitoring and provides patients with insights into their recovery progress and offers a tailored exercise program. The aim of this study was to investigate the potential of Hospital Fit to enhance PA levels and functional recovery following orthopedic surgery.

Methods

PA was measured with an accelerometer postoperatively until discharge. The control group received standard physiotherapy, while the intervention group used Hospital Fit in addition to physiotherapy. The time spent active and functional recovery (modified Iowa Level of Assistance Scale) on postoperative day one (POD1) were measured.

Results

Ninety-seven patients undergoing total knee or hip arthroplasty were recruited. Hospital Fit use, corrected for age, resulted in patients standing and walking on POD1 for an average increase of 28.43 min (95% confidence interval (CI): 5.55-51.32). The odds of achieving functional recovery on POD1, corrected for the American Society of Anesthesiologists classification, were 3.08 times higher (95% CI: 1.14–8.31) with Hospital Fit use.

Conclusions

A smartphone app combined with an accelerometer demonstrates the potential to enhance patients' PA levels and functional recovery during hospitalization.

INTRODUCTION

Elective joint replacement is an effective and successful intervention in patients suffering from end-stage osteoarthritis¹⁻⁴. Due to the rising prevalence of osteoarthritis, the number of total knee arthroplasty (TKA) and total hip arthroplasty (THA) procedures performed annually is increasing steadily. The American Joint Replacement Registry (AJJR) shows that 139,582 primary TKA procedures and 93,122 primary THA procedures were undertaken in the United States of America in 2018⁵.

The perioperative care process around TKA and THA procedures has greatly improved in recent years due to advances in surgical techniques and the introduction of clinical care pathways⁶⁻⁸. Clinical care pathways are directed at preparing the patient for discharge as soon as possible after surgery, without compromising outcomes^{3,8,9}. Postoperative mobilization on the day of surgery within a pathway-controlled fast-track program is associated with a reduced length of stay (LOS), enhanced functional recovery, reduced pain, and lower mortality rates^{8,10,11}.

Although the beneficial effects of physical activity (PA) during hospitalization are well documented, patients continue to spend between 92% and 96% of their time lying or sitting¹²⁻¹⁴. Therefore, strategies aimed at increasing the amount of time spent standing and walking are needed¹⁵. Postoperative physiotherapy is aimed at enhancing PA levels and functional recovery of activities of daily living which are essential in order to function independently at home^{9,16-18}. However, physiotherapists lack objective insight into the amount of time patients are active. In order to advise patients effectively on their PA behavior, continuous PA monitoring with real-time feedback should be implemented in standard care.

mHealth could provide a solution to this issue¹⁹. mHealth has been defined by the WHO as “medical and public health practice supported by mobile devices, such as smartphones, tablets or wireless patient-monitoring sensors”^{19,20}. mHealth has been developed for many different purposes. It has been applied for the management of blood pressure, management of glucose levels, fall detection, mental health, medication management and PA monitoring^{19,21}. PA can be monitored by connecting external wearable devices such as accelerometers, gyroscopes or pedometers, to a smartphone or tablet via Bluetooth^{21,22}. Wearable sensors can also be embedded in a smartphone or smartwatch^{21,23}. These remote measurement technologies enable continuous PA monitoring and have the advantage of providing patients and healthcare providers real-time feedback. Prior studies have demonstrated that smartphone applications combined with an activity tracker are able to increase the amount of PA of the user^{24,25}. Depending on the intended use, additional

functionalities such as educational material, exercise programs or capturing patient reported outcomes (PROMs), could also be added to mHealth tools to enhance the possibilities.

mHealth tools support the prevention and treatment of low levels of PA as well as stimulate functional recovery. They have the potential to increase patient awareness, support personalized care, and stimulate self-management. Furthermore, they can motivate patients in the absence of healthcare providers and make them more active and effective managers of their recovery^{24,26,27}.

Within the orthopedic rehabilitation pathway, mHealth tools are being used to monitor PA in support of outpatient physiotherapy²⁸⁻³⁰. The use of mHealth to monitor PA has also been shown to be beneficial to other areas of research. mHealth tools have demonstrated their ability to stimulate the PA of patients with coronary heart disease (CHD)^{23,31}, chronic obstructive pulmonary disease (COPD)²⁶, type II diabetes²⁶ and can motivate the elderly to undertake PAs when implemented in a care home¹⁹.

So far, no mHealth tool is available that offers hospitalized patients and their physiotherapists essential strategies to enhance their PA levels and support their recovery process. Most accelerometry-based activity monitors are validated in healthy adults and lack the sensitivity to measure slow gait^{32,33}. Due to the frequent use of walking aids as well as slow and impaired gait, the algorithm of most of the available activity monitors is not validated in terms of being used in hospitalized patients. Therefore, the Department of Physiotherapy of Maastricht University Medical Center (MUMC+) and Maastricht Instruments B.V. developed Hospital Fit (HFITAPPO, Maastricht Instruments B.V., the Netherlands). Hospital Fit is designed to be used in hospitalized patients and consists of a smartphone application connected to an accelerometer. The algorithm of the accelerometer has been validated to differentiate lying and sitting from standing and walking in hospitalized patients³⁴⁻³⁶. It provides patients and physiotherapists feedback on the number of minutes spent standing and walking per day. Additionally, it provides patients insight into their own recovery progress, and a tailored exercise program supported by videos. Hospital Fit has been implemented in the standard physiotherapy treatment of patients following TKA and THA in Maastricht University Medical Center since February 2019.

The primary aim of this pilot study was to get a first impression of whether introducing Hospital Fit as part of standard physiotherapy treatments has led to a change in the amount of PA of hospitalized patients who had undergone elective TKA or THA. The secondary aim was to explore whether Hospital Fit has led to a change in the time until functional recovery is achieved in this population.

MATERIALS AND METHODS

Study design

This single center pilot study, with a non-randomized quasi-experimental design, was conducted at Maastricht University Medical Center in Maastricht, the Netherlands, between January 2017 and May 2019.

Study population

Patients scheduled for an elective TKA or THA at the orthopedic ward of Maastricht University Medical Center were invited to participate. Patients scheduled for surgery between January 2017 and December 2018 were recruited for the control group. During this period, Hospital Fit was being developed. Due to the limited number of accelerometers available, only one patient per week was recruited. In December 2018, the development of Hospital Fit was completed. A one-month implementation phase followed in January 2019, during which no patients were enrolled. Patients scheduled for surgery between February 2019 and May 2019 were recruited for the intervention group. After the implementation phase, sufficient accelerometers had become available, enabling the recruitment of consecutive patients in the intervention group. No other changes were made in the clinical care pathway during the study period.

Patients received verbal and written information about the study at preoperative physiotherapy screenings, scheduled six weeks before surgery. A research physiotherapist contacted the patients again on the day of their surgery, and written informed consent was obtained before study initiation. The confidential processing of data and anonymity were guaranteed.

Patients were eligible if they met the following inclusion criteria: receiving physiotherapy after elective TKA or THA, able to walk independently two weeks prior to surgery as scored on the functional ambulation categories (FAC >3)³⁷, they were expected to be discharged to their own home, aged 18 years and older, and had a sufficient understanding of the Dutch language. Exclusion criteria were: the presence of contraindications to walking or wearing an accelerometer on the upper leg, admission to the intensive care unit, impaired cognition (delirium/dementia) as reported by the attending doctor, a life expectancy of less than three months, and previous participation in this study. This study was performed in compliance with the Declaration of Helsinki and was approved by the Medical Ethics Committee of the University Hospital Maastricht and Maastricht University (METC azM/UM), registration number 2017-0175.

Procedure

Patients were enrolled after signing informed consent. All patients followed a standardized clinical care pathway for TKA or THA. Preoperatively, paracetamol, gabapentin, naproxen and a gastric protector were administered. Surgery was performed under spinal or general anesthesia in combination with a local infiltration analgesia (ropivacaine, morphine-sulphate, adrenaline). In TKA procedures, a medial parapatellar approach was used with a posterior stabilized implant. In THA procedures, a posterior approach of the hip joint was used. Pain medication was continued until discharge—with the addition of oxycodone. Postoperative physiotherapy was administered to all participating patients, starting within four hours after surgery. The physiotherapy treatment was aimed at increasing PA levels and enhancing functional recovery. Patients received physiotherapy twice daily (30 min per session) until functional recovery was achieved, as measured with the modified Iowa Level of Assistance Scale (mILAS)³⁸. Patients in the control group received postoperative physiotherapy and had their PA levels monitored with an accelerometer without receiving feedback. Patients in the intervention group received the same physiotherapy treatment, but Hospital Fit was used in addition.

Device description

The PA levels were assessed with the MOX activity monitor (MOX; Maastricht Instruments B.V., the Netherlands (Figure 5.1)). The device contained a tri-axial accelerometer sensor (ADXL362; Analog Devices, Norwood, MA, USA) in a small waterproof housing (35 × 35 × 10 mm, 11 g). Raw acceleration data (± 8 g) were measured in three orthogonal sensor axes (X, Y and Z) at a 25 Hz sampling rate. The accelerometer was factory calibrated against gravity for each axis. The raw acceleration data were converted to a PA classification using a previously described embedded algorithm³⁴. After sensor noise reduction, the data were segmented in to one-second long windows using a fixed non-overlapping sliding window. Based on the amount of activity, each window was classified as dynamic or static. For the static windows, the sensor orientation was assessed. Based on a cut-off value of 0.8 g the static windows were classified as standing or sedentary. Each minute the classified results were sent to the Hospital Fit smartphone application via a Bluetooth protocol.

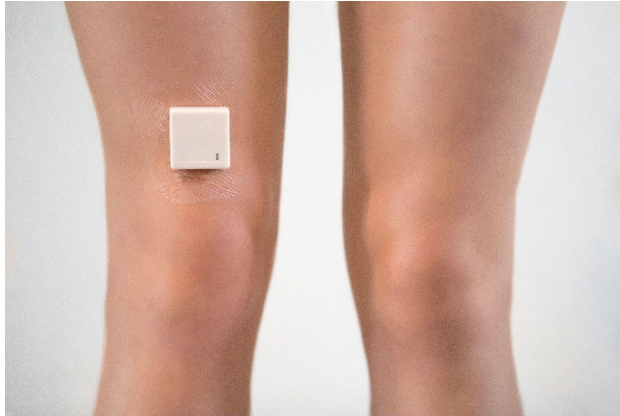

Figure 5.1 The MOX activity monitor.

Hospital Fit

Hospital Fit consists of a smartphone-based app which is connected to the MOX Activity Monitor via Bluetooth. It contains a separate interface for patients and physiotherapists, enabling extensive options for physiotherapists. During the first treatment, the physiotherapist applied the accelerometer and installed the app on the patients' smartphone. The physiotherapist subsequently initiated a connection between the accelerometer and the app by starting a new measurement in the physiotherapist interface.

The PA overview provides patients and their physiotherapists real-time feedback on the number of minutes spent standing and walking per day. An overview was provided per day (Figure 5.2A), with the possibility to look back at the PA levels of previous days. Additionally, a weekly overview was provided to enable the monitoring of the progress in PA levels over time (Figure 5.2B).

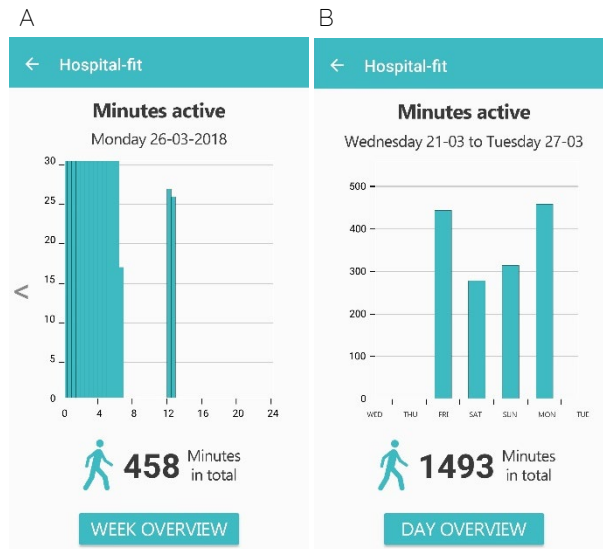

Figure 5.2 Overview of the total number of minutes spent standing and walking per day (A) and per week (B).

The recovery assessment gave patients the option of gaining insight into their own recovery progress. The extent of functional recovery can be evaluated by the physiotherapist during every treatment. The ability of patients to perform the activities of daily living was scored on the physiotherapist interface based on the mLAS (Figure 5.3A). The mLAS assesses the ability of patients to perform several activities of daily living (transfer from the supine position to sitting and vice versa, sit-to-stand, walking, and stair climbing) and rates the amount of assistance and type of walking aid needed. The degree of assistance needed to perform each task safely was scored (0–6 points score per item). The total scores range from 0 to 30, with zero reflecting independence for all items. Stair climbing was only assessed if the patient needed to climb stairs at home; otherwise this item was scored as zero³⁸. Because accelerometers are not able to measure the amount of assistance or the type of walking aid needed during PA, scoring the extent of functional recovery had to be performed by the physiotherapist. If necessary, the extent of functional recovery could be adapted multiple times per day.

The mLAS-score was transformed into a percentage score in the app, with 100% indicating complete independency. The percentage scores were provided per activity, showing which activities need improvement in order to reach functional recovery. The percentage scores are supported by a graph, showing progress in functional recovery over time (Figure 5.3B). More detailed information on the amount of assistance needed is provided per activity, supported by a graph

showing the progress over time per activity (Figure 5.3C). The physiotherapist interface enables the extent of functional recovery to be scored as well as providing an overview. The patient interface only provides an overview of the extent of functional recovery.



Figure 5.3 Recovery assessment with the option of scoring the extent of functional recovery based on the modified Iowa Level of Assistance Scale (A); an overview of the extent of functional recovery (B); the amount of assistance needed and progress over time per activity (C).

Furthermore, the physiotherapist interface contains the option of creating a patient-specific exercise program supported by videos. Hospital Fit contains a database of 25 videos aimed at enhancing functional recovery, upper and lower leg strength, and physical fitness (Figure 5.4). The videos supporting functional recovery were designed especially for hospitalized patients and show patients how to transfer from the supine position to sitting and vice versa, sit-to-stand, walk, and climb stairs with different types of walking aids. The videos supported the physiotherapy treatment and were aimed at stimulating self-management. After each treatment, the physiotherapist selected appropriate videos, thereby creating a personalized exercise program. If preferred, a note containing personalized information on the number of repetitions or intensity of the exercise could be added as well. The physiotherapist could adapt the exercise program as often as necessary. The patient interface enabled the patient to view the videos as often as they preferred. During each treatment session, the physiotherapist and patient evaluated the amount of PA, extent of functional recovery and the exercise program.

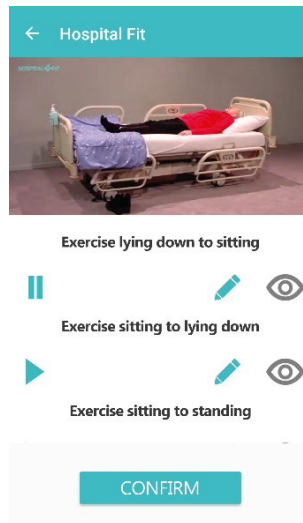

Figure 5.4 Exercise videos.

Outcome measures

Physical activity

The primary outcome measure was the time spent physically active (total number of minutes standing and walking) per day. The time spent standing and walking was considered the most important outcome since hospitalized patients spend large amounts of time lying and sitting. The MOX activity monitor has been validated to differentiate lying and sitting from standing and walking in hospitalized patients. It has a high validity to estimate the time spent on the activities and postures in a controlled laboratory setting and in free-living conditions^{35,36}.

During the first treatment session, the accelerometer was attached to the upper leg with a hypoallergenic patch (ten centimeters proximal to the patella, on the non-operated leg). The position of the accelerometer is visualized in Figure 5.5.

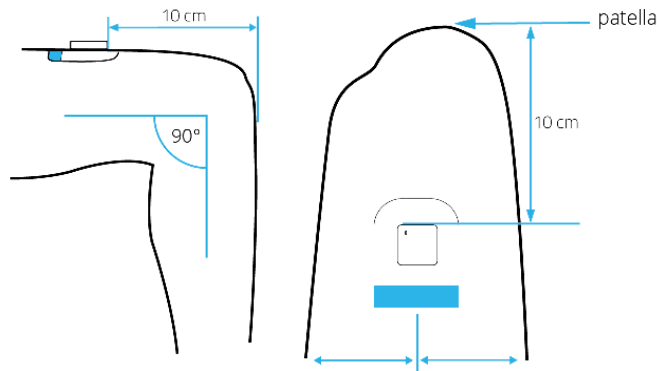

Figure 5.5 Lateral view (A) and frontal view (B) of the placement of the MOX activity monitor with the patient in a seated position. Arrows indicate the location of the hypoallergenic patch and sensor on the upper leg, which is 10 cm proximal to the patella.

PA was monitored 24 h per day. Days with ≥ 20 h of wear time were considered valid measurement days and were included in the analysis. After the last treatment session, the accelerometer was removed and the raw tri-axial accelerometer data (Figure 5.6) were uploaded to a computer.

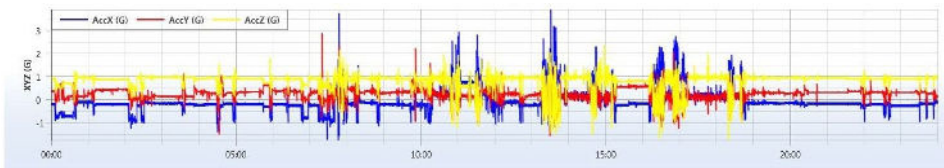

Figure 5.6 Example of the raw tri-axial accelerometer data of one subject for one measurement day. One measurement day (24 h) is represented on the x -axis. G-forces per sensor axes (X, Y and Z) are represented on the y -axis.

MATLAB (version 9.5 (R2018b) Natick, Massachusetts: The MathWorks Inc.: *Natick*, MA, USA; 2018) was used to calculate the total number of minutes spent standing and walking per day. A schematic overview of the data processing is shown in Figure 5.7.

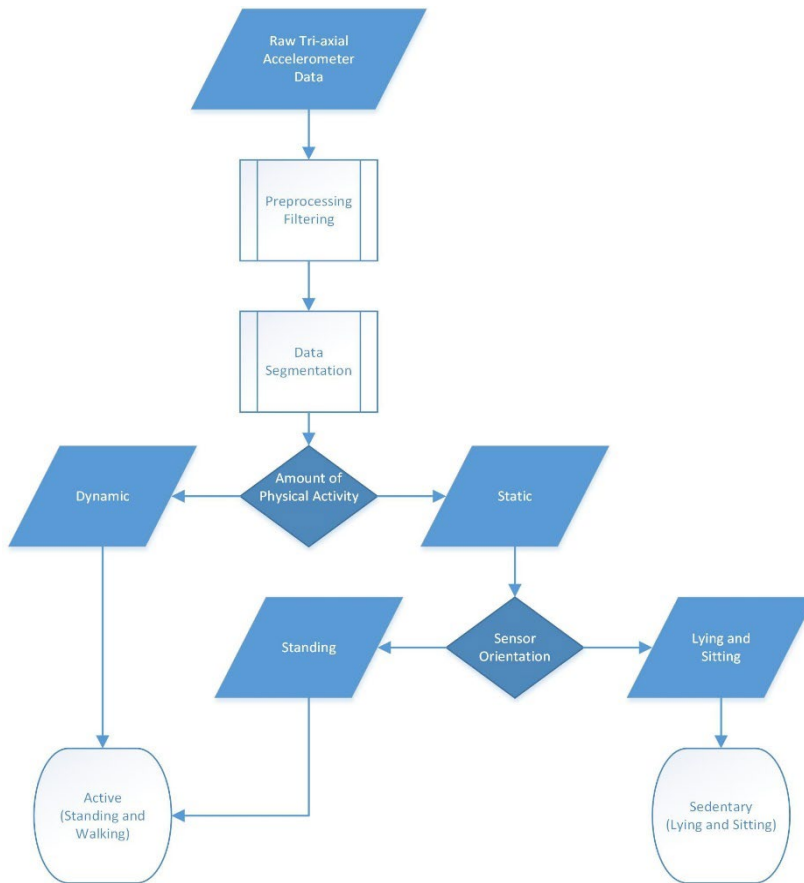

Figure 5.7 Data processing—a schematic overview of the physical activity classification algorithm for the accelerometer worn on the upper leg location.

Functional recovery

The secondary outcome measure was the achievement of functional recovery on postoperative day one (POD1). Functional recovery was assessed by the physiotherapist during each treatment session using the mLAS and was reported in the electronic health record. In the intervention group, it was also reported in the app. The achievement of functional recovery on POD1 was defined as having reached a total mLAS-score of zero on or before POD1, using a dichotomized outcome (0 = mLAS=0 >POD1; 1 = mLAS=0 ≤POD1). The mLAS shows a high reliability, validity and responsiveness when used to measure functional recovery in the acute phase after TKA or THA³⁸.

The independent variables measured were: Hospital Fit use (control versus the intervention group), age, sex, body mass index (BMI), type of surgery (TKA or THA), and comorbidities assessed by the American Society of Anesthesiologists (ASA) classification (ASA-class ≤ 2 versus ASA-class=3; a higher score indicates being less fit for surgery). The medical and demographic data measured were the type of walking aid used and LOS, with the day of surgery being defined as day one. All measurements were extracted from the electronic health record.

Sample size calculation

Based on a significance level of 0.05, a power of 0.80, an effect size of 0.20, and five determinants, a sample size of $n=75$ was needed. Due to a lack of representable data available to determine the effect size, it was determined based on Cohen's rule of thumb, indicating a medium to large effect size³⁹. Accounting for a 20% drop-out rate, we aimed to enroll $n=94$ patients in this study. The ratio between patients included in the control and intervention group was set at 2:1, respectively. The data analysis was performed according to the intention-to-treat principle. Missing values were not substituted and drop-outs were not replaced.

Data analysis

Descriptive statistics are presented as means, and standard deviations (SD) or 95% confidence intervals (CI) for continuous variables. The median and interquartile ranges (IQR) were used to present not normally distributed data. The frequencies and percentages were used to present categorical variables. A multiple linear regression analysis was performed to determine the association between the time spent physically active per day and Hospital Fit use, corrected for potential confounding factors (age, sex, BMI, ASA-class, and type of surgery). A univariate regression analysis was performed to determine the association between the time spent physically active per day and Hospital Fit use. Next, potential confounding variables were added (enter method) to explore the association between Hospital Fit use and the time spent physically active per day, corrected for confounding variables. Variables that resulted in a $\geq 10\%$ change in the regression coefficient of the main determinant (Hospital Fit use) were eligible for inclusion in the model. The variable contributing the most was included in the multiple regression model first, followed by the next variable leading to the highest percentage ($\geq 10\%$) of change in the main regression coefficient. This process was repeated until there were no more potential confounding factors, resulting in the final model⁴⁰. A multiple logistic regression analysis was performed additionally, to determine the association between the achievement of functional recovery on POD1 and Hospital Fit use, corrected for potential confounding factors. The same procedure was performed as in the linear regression analysis and the same potential confounding variables were explored. Assumptions were checked for both regression analyses by residual plots

and statistics. For all statistical analyses, the level of significance was set at $P < 0.05$. All statistical analyses were performed using SPSS (version 23.0.0.2; IBM Corporation Armonk, NY, USA).

RESULTS

In total, 97 patients were willing and able to participate. The baseline characteristics of both groups are listed in Table 5.1. Of these patients, nine (9.3%) were excluded because of missing data (no valid measurement day of ≥ 20 h of wear time due to a delayed postoperative fixation of the accelerometer ($n=5$) or discharge on POD1 ($n=1$)), and accelerometer malfunctioning ($n=3$).

Table 5.1 Characteristics of study participants.

	Control Group ($n=64$)	Intervention Group ($n=33$)
Age, years (median, IQR)	66.60 (10.62)	65.10 (13.72)
Sex (n , %)		
Female	24 (38)	18 (55)
Male	40 (63)	15 (45)
BMI, kg/m ² (median, IQR)	27.73 (4.72)	27.47 (4.70)
Type of surgery (n , %):		
Total knee arthroplasty	49 (77)	15 (45)
Total hip arthroplasty	15 (23)	18 (55)
ASA-class (n , %):		
ASA 1-2	53 (83)	26 (79)
ASA 3	11 (17)	7 (21)
Walking aid (n , %):		
Two crutches	53 (83)	31 (94)
One crutch	1 (2)	-
Walking frame	5 (8)	1 (3)
Walker	5 (8)	1 (3)
LOS, days (median, IQR)	3.00 (1)	3.00 (0)

IQR=interquartile range, BMI=body mass index, ASA=American Society of Anesthesiologists, LOS=length of stay in hospital, with the day of surgery being defined as day one.

This left 88 cases (90.7%) for analysis, 61 (69%) in the control group and 27 (31%) in the intervention group. In the control group, the median age (interquartile range (IQR)) was 67.19 (11.35) years and 46 patients (72%) had undergone TKA. The control group consisted of 23 women (38%) and 38 men (62%). Fifty patients had an ASA-class of 1 to 2 (82%) and 11 patients (18%) had an ASA-class of 3. The median (IQR) LOS was 3.00 (1) days. In the intervention group, the median age (IQR) was 63.73 (16.62) years and 14 patients (52%) had undergone TKA. The intervention group consisted of 16 women (59%) and 11 men (41%). Nineteen patients had an ASA-class of 1 to 2 (70%) and eight patients (30%) had an ASA-class of 3. The median (IQR) LOS was 3.00 (0) days. The missing values were negligible; data on the achievement

of functional recovery on POD1 ($n=4$) were missing. Differences in the baseline characteristics were accounted for in the regression analyses.

A median (IQR) number of 1.00 (0) valid measurement days (≥ 20 h wear time) was collected. PA data for 84 patients (95%) was available on POD1 ($n=61$ control group, $n=23$ intervention group). On postoperative day two (POD2), the majority of patients were discharged ($n=61$, 69%), and data for only 23 patients (26%) were available ($n=17$ control group, $n=6$ intervention group). From postoperative day three until day seven, data of the valid measurement days were available for just one patient (intervention group). Due to the large reduction in valid measurement days from POD2 onwards, data of these days were not included in the analysis.

The results of the univariate linear regression analysis are shown in Table 5.2. The results show that Hospital Fit use led to an increase of 32.10 (95% CI: 9.35–54.84) minutes standing and walking on POD1. Patients who did not use Hospital Fit stood and walked on average 70.89 (95% CI: 59.00–82.80) minutes on POD1 compared to 102.99 (95% CI: 82.77–123.21) minutes in patients who used Hospital Fit.

Table 5.2 Univariate linear regression analysis—the association between the time spent physically active on postoperative day one (POD1) and Hospital Fit use.

	B	Std. Error	P-Value	95% Confidence Interval for B	
				Lower Bound	Upper Bound
Constant	70.89	5.98	0.000	59.00	82.80
Hospital Fit use	32.10	11.43	0.006	9.35	54.84

POD1=postoperative day one.

To correct for the influence of potential confounders (age, sex, BMI, ASA-class, and type of surgery), the association between Hospital Fit use and the time spent physically active per day was explored. The addition of age resulted in a 11.41% change in the regression coefficient of the main determinant (Hospital Fit use) and was therefore added to the model. The remaining variables were then added to the model corrected for age, but each resulted in a <10% change in the regression coefficient of the main determinant and were therefore not included. The results of the multiple linear regression analysis are shown in Table 5.3. The results show that, corrected for age, patients who used Hospital Fit stood and walked on average 28.43 min (95% CI: 5.55–51.32) more on POD1 than patients who did not use Hospital Fit. The model shows that an increase in age led to a decrease in the number of minutes standing and walking on POD1.

Table 5.3 Multiple linear regression analysis—the association between the time spent physically active on POD1 and Hospital Fit use, corrected for age.

	B	Std. Error	<i>p</i> -Value	95% Confidence Interval for B	
				Lower Bound	Upper Bound
Constant	124.25	31.80	0.000	60.98	187.52
Hospital Fit use	28.43	11.50	0.016	5.55	51.32
Age	-0.81	0.48	0.092	-1.76	0.13

POD1=postoperative day one.

The results of the univariate logistic regression analysis (Table 5.4) show that the odds of achieving functional recovery on POD1 were 2.72 times higher (95% CI: 1.05-7.049) for patients who used Hospital Fit than for patients who did not use Hospital Fit.

Table 5.4 Univariate logistic regression analysis—the association between the achievement of functional recovery on POD1 and Hospital Fit use.

	B	Std. Error	<i>P</i> -Value	Odds Ratio	95% Confidence Interval for Odds Ratio	
					Lower Bound	Upper Bound
Constant	-0.31	0.26	0.243	0.735	-	-
Hospital Fit use	1.00	0.49	0.039	2.720	1.050	7.049

POD1=postoperative day one.

The influence of potential confounders on the association between the Hospital Fit use and time spent physically active per day was explored. Addition of ASA-class resulted in the largest change of 12.38% in the regression coefficient of the main determinant (Hospital Fit use) and was added to the model. The remaining variables were then added to the model corrected for ASA-class, but each resulted in a <10% change in the regression coefficient of the main determinant and were therefore not included. The results of the multiple logistic regression analysis (Table 5.5) show that, corrected for ASA-class, the odds of achieving functional recovery on POD1 were 3.08 times higher (95% CI: 1.14-8.31) for patients who used Hospital Fit than for patients who did not use Hospital Fit. Including ASA-class in the model shows that a lower ASA-class increased the odds ratio for a functional recovery on POD1.

Table 5.5 Multiple logistic regression analysis—the association between the achievement of functional recovery on POD1 and Hospital Fit use, corrected for ASA-class.

	B	Std. Error	<i>P</i> -Value	Odds Ratio	95% Confidence Interval for Odds Ratio	
					Lower Bound	Upper Bound
Constant	-0.91	0.58	0.112	0.401	-	-
Hospital Fit use	1.13	0.51	0.026	3.080	1.14	8.31
ASA-class	0.71	0.59	0.228	2.03	0.64	6.39

POD1=postoperative day one, ASA=American Society of Anesthesiologists.

DISCUSSION

In this pilot study we aimed to gain a first impression of whether Hospital Fit has the potential to improve the amount of PA and time until functional recovery is achieved in hospitalized patients following orthopedic surgery. The results show an increase in the time spent standing and walking, as well as higher odds of functional recovery on POD1 from the introduction of Hospital Fit. Although the guidelines on the recommended amount of PA during hospitalization do not yet exist, an average improvement of 28 min (39%) standing and walking on POD1 can be considered a clinically relevant contribution to prevent the negative effects of inactivity.

The relatively large confidence intervals indicate a large variation in PA levels during hospitalization. These large differences in the PA levels of hospitalized patients are seen in many other studies as well^{13,14,41,42}. PA levels can be influenced by many different factors such as symptoms, the motivation of the patient, awareness of the importance of PA, the availability of healthcare staff to assist patients during walking, or the availability of adequate walking aids^{15,43,44}. These factors are expected to result in large differences in PA levels between patients.

Wearable technology is increasingly being used in TKA and THA research, with the assessment of PA, functional parameters, and gait analysis as primary modes of investigation. No standard outcome measure or testing methodology has been established in wearable-based PA monitoring following TKA or THA⁴⁵. Technology, testing protocol and sensor-based outcome variables may vary and may affect the quality and reliability of the data being collected⁴⁶⁻⁴⁹.

Limited research has been conducted on monitoring PA during the early recovery phase following TKA or THA⁴⁵. Eight studies have been performed, with sensor-based outcome variables varying considerably between studies^{28,50-56}. Two studies investigated the amount of time spent active (standing and walking) as outcome variables in the monitoring of PA of hospitalized patients following TKA^{50,51}. Schotanus et al.⁵⁰ showed that patients within an enhanced recovery pathway spent 9% of their waking hours standing and walking on POD1. On POD2, this increased towards 11%, with a planned discharge within three days post-operation. PA was measured with a triaxial accelerometer (GC Dataconcepts LLC, Waveland, USA) attached to the non-operated thigh. No details were provided regarding the validity of the algorithm to differentiate lying and sitting from standing and walking in hospitalized patients. Due to the lack of insight into the number of waking hours, the results cannot be compared to our study. In agreement with our study, they concluded that accelerometry is an added value for the objective analysis of PA during the early recovery phase in patients after TKA⁵⁰. Fenten et al.⁵¹ compared the amount of time spent active per day between patients receiving periarticular local

anesthetic infiltration (LIA), and patients receiving LIA of the posterior knee capsule in combination with a femoral nerve block (FNB) catheter. PA was monitored with an accelerometer, attached to the non-operated thigh. No details were provided regarding the accelerometer type or the validity of the algorithm to differentiate lying and sitting from standing and walking in hospitalized patients. PA was monitored between 8 am and 8 pm on the day of surgery and on POD1. The mean time spent active (SD) on POD1 was 20.5 (14.9) minutes in the FNB group versus 27.7 (14.1) minutes in the LIA group⁵¹. Although the postoperative physiotherapy treatment and LOS were comparable, our study shows higher amounts of time spent active on POD1. Patients who did not use Hospital Fit spent 70.89 (95% CI: 58.93–82.86) minutes active compared to 102.99 (95% CI: 82.77–123.21) minutes in patients who used Hospital Fit. These differences might be explained by the fact that, in our study, PA was monitored continuously for 24 h per day and patients scheduled for a prolonged stay in an outpatient rehab clinic were excluded. So far, no studies have investigated the amount of time spent active in hospitalized patients following THA.

One of the main aims of Hospital Fit is to decrease the negative effects of sedentary behavior in hospitalized patients through stimulating the amount of time spent active. As hospitalized patients spend over 92% of their time lying or sitting¹²⁻¹⁴, the number of minutes spent standing and walking per day is deemed the most appropriate sensor-based outcome variable for Hospital Fit. Additionally, it is a practical outcome variable since it is easily interpreted by patients and physiotherapists.

Three studies investigated intensity (activity counts) as an outcome variable in monitoring the PA of hospitalized patients following TKA⁵²⁻⁵⁴ and THA^{52,53}. We believe however, that monitoring the time spent active is more meaningful than monitoring intensity levels (activity counts) in the early recovery phase after surgery. First, the intensity of PA as perceived by patients may deviate from the intensity measured by the accelerometer. During the first days after surgery, patients may perceive ambulation at low walking speeds as a high intensity activity, while the accelerometer objectively classifies this as a low intensity activity. Second, in the early recovery phase after surgery, the focus of physiotherapy lies on the recovery of activities which are essential to perform at home, such as walking and stair climbing. The focus does not lie on the intensity of the activities performed.

Three studies investigated step counts as an outcome variable in the monitoring of PA of hospitalized patients following TKA^{28,55,56} and THA⁵⁵. Using step counts to quantify PA has advantages since it is specific to ambulation and is easily interpreted by patients and physiotherapists⁵⁷. However, during the early recovery phase after TKA and THA, all patients require a walking aid, and slow and impaired

gaits are common⁵⁸. Several studies have shown that these factors decrease the validity of activity trackers to measure step counts⁵⁹⁻⁶². Furthermore, movements of the arms or legs performed in bed or on a chair may result in an overestimation of the number of steps taken. We therefore consider the time spent active a more appropriate outcome variable for Hospital Fit than step counts.

The present study investigated an mHealth tool which uses a multimodal approach, tailored specifically to the needs of hospitalized patients and their physiotherapists. Besides objective activity monitoring, Hospital Fit also provides patients insight into their recovery progress and offers physiotherapists the option of creating a patient-specific exercise program supported by videos. Recently, an increasing number of other mHealth tools have been investigated within the orthopedic rehabilitation pathway^{28-30,63-69}. These tools are predominantly prescribed in support of outpatient physiotherapy. Besides monitoring PA, they are being used to offer biofeedback in exercise programs, monitor the range of motion (ROM) of the knee joint, capture PROMs, provide educational material and enable telerehabilitation.

Inertial measurement units (IMUs) contain accelerometers paired with gyroscopes and magnetometers, to provide a detailed analysis of limb movements and orientations within a spatial reference frame⁴⁵. The use of IMUs enables patients to receive feedback on the performance of their exercise technique based on supervised machine learning. It also enables counting exercise repetitions as well as recording the ROM of the knee joint. These options can offer additional motivation and feedback to enhance adherence, and can positively impact the patient experience and clinical outcome. Although this technology seems promising, there is a need for such systems to demonstrate a real-world accuracy validation^{70,71}.

Furthermore, some mHealth tools describe using the internal proprietary algorithm of the patient's smartphone to passively measure their step count^{28,29}. This requires patients to carry their smartphones with them in order to not make an underestimation of the amount of PA performed. During hospitalization however, patients often wear hospital gowns or pajamas without pockets, or leave their smartphones on their nightstand. Therefore, monitoring PA through a smartphone is not recommended in hospitalized patients. Hospital Fit is equipped with an accelerometer attached to the upper leg, and the algorithm is able to differentiate lying and sitting from standing and walking in patients using walking aids, or with slow or impaired gait. This is an advantage over many smartphones and commercially available activity trackers and one of the reasons Hospital Fit was developed.

This study was not without limitations. We acknowledge that with the current study design, the results may not only be attributable to the introduction of Hospital Fit.

The current design enabled us to effectively use the time in which Hospital Fit was developed to include patients in the control group, and give us a first impression of the potential of Hospital Fit. Unfortunately, due to technological challenges, the development of Hospital Fit took longer than anticipated. Although the clinical care pathway and physiotherapy treatment did not change during this period, awareness on the importance of PA during hospitalization might have increased among patients and healthcare professionals, which may have resulted in a bias in favor of the intervention group. This could have led to a slight overestimation of the results.

Additionally, the individual functionalities of Hospital Fit were not investigated in this pilot study. Therefore, we cannot establish the relationship between each functionality and PA. Enabling this would have provided valuable information regarding the contribution of the different functionalities on the influence of Hospital Fit.

Furthermore, when this study was designed in 2016, the median (range) postoperative LOS was 6 (4-10) days. The implementation of a new clinical care pathway in November 2016 has resulted in a reduction in the median (range) LOS to 4 (3-12) days, leaving a relatively short period to introduce and use Hospital Fit⁸. In our study, the majority of patients were discharged on POD2 and data for only 23 patients were available on POD2. Because the data of these remaining 23 patients were not representative of the whole population and resulted in insufficient power to perform a regression analysis, only data on the amount of PA performed on POD1 were included in the analysis.

The present study has a number of important implications for daily practice and future research. First, the results show that Hospital Fit has the potential to enhance the amount of PA and functional recovery in hospitalized patients, especially when the hospital stay permits the use of the application for a longer period. Second, since the literature on the amount of PA performed in hospitalized patients following TKA and THA is scarce, this study contributes to the knowledge of the PA behavior of this population. Third, continuous objective monitoring provides patients and their physiotherapists the advantage of being able to set goals regarding the amount of PA. However, reference values regarding the optimal amount of PA after surgery do not exist yet. Hospital Fit and the data it creates have tremendous potential, because continuous PA monitoring as part of standard care will enable creating population norms for PA.

In order to determine the effectiveness of Hospital Fit, it is recommended that this pilot study should be followed by a larger, cluster randomized controlled trial in a population of hospitalized patients with a longer LOS. In order to determine the

effect of each functionality of Hospital Fit on PA, investigating the individual functionalities is recommended as well.

CONCLUSIONS

This pilot study aimed to gain a first impression of whether Hospital Fit has the potential to improve the amount of PA and shorten the time until functional recovery is achieved in hospitalized patients following orthopedic surgery. The results show an increase in patients' time spent standing and walking, as well as higher odds of functional recovery on POD1 due to the introduction of Hospital Fit. This study shows that a smartphone app combined with an accelerometer demonstrates potential to enhance patients' PA levels and recovery processes during hospitalization.

ACKNOWLEDGEMENTS

We would like to thank all physiotherapists working at Maastricht University Medical Center for their assistance in this study. We would also like to thank W.J.P. Bijmens of Maastricht University for his assistance in creating a customized MATLAB program, and S.M.J. van Kuijk of Maastricht University Medical Center for his assistance in the statistical analysis.

REFERENCES

1. Jansson MM, Harjumaa M, Puhto AP, Pikkarainen M. Patients' satisfaction and experiences during elective primary fast-track total hip and knee arthroplasty journey: A qualitative study. *J Clin Nurs*. 2020;29(3-4):567-82
2. Berghmans DDP, Lenssen AF, Emans PJ, de Bie RA. Functions, disabilities and perceived health in the first year after total knee arthroplasty: a prospective cohort study. *BMC Musculoskelet Disord*. 2018;19(1):250
3. Ibrahim MS, Khan MA, Nizam I, Haddad FS. Peri-operative interventions producing better functional outcomes and enhanced recovery following total hip and knee arthroplasty: an evidence-based review. *BMC Med*. 2013, 11, 37.
4. Carr AJ, Robertsson O, Graves S, Price AJ, Arden NK, Judge A, Beard DJ. Knee replacement. *Lancet* (London, England) 2012, 379, 1331-40,
5. (AJRR), A.J.R.R. 2019 Annual Report; American Academy of Orthopaedic Surgeons (AAOS): Rosemont, IL, United States of America, 2019.
6. Soeters R, White PB, Murray-Weir M, Koltsov JCB, Alexiades MM, Ranawat AS. Preoperative Physical Therapy Education Reduces Time to Meet Functional Milestones After Total Joint Arthroplasty. *Clin Orthop Relat Res* 2018;476:40-8.
7. Tanzer D, Smith K, Tanzer M. Changing Patient Expectations Decreases Length of Stay in an Enhanced Recovery Program for THA. *Clin Orthop Relat Res*. 2018, 476, 372-8.
8. Didden AGM, Punt IM, Feczko PZ, Lenssen AF. Enhanced recovery in usual health care improves functional recovery after total knee arthroplasty. *Int J Orthop Trauma Nurs* 2019;34:9-15.
9. Engdal M, Foss OA, Taraldsen K, Husby VS, Winther SB. Daily Physical Activity in Total Hip Arthroplasty Patients Undergoing Different Surgical Approaches: A Cohort Study. *Am J Phys Med Rehabil*. 2017;96:473-8.
10. den Hertog A, Gliesche K, Timm J, Muhlbauer B, Zebrowski S. Pathway-controlled fast-track rehabilitation after total knee arthroplasty: a randomized prospective clinical study evaluating the recovery pattern, drug consumption, and length of stay. *Arch Orthop Trauma Surg*. 2012;132:1153-63.
11. Malviya A, Martin K, Harper I, Muller SD, Emmerson KP, Partington PF, Reed MR. Enhanced recovery program for hip and knee replacement reduces death rate. *Acta Orthop* 2011;82:577-81.
12. Brown CJ, Roth,DL, Allman RM. Validation of use of wireless monitors to measure levels of mobility during hospitalization. *J Rehabil Res Dev*. 2008;45:551-8.
13. Pedersen MM, Bodilsen AC, Petersen J, Beyer N, Andersen O, Lawson-Smith L, Kehlet H, Bandholm T. Twenty-four-hour mobility during acute hospitalization in older medical patients. *J Gerontol. A Biol Sci Med Sci*. 2013;68:331-7.
14. Evensen S, Sletvold O, Lydersen S, Taraldsen K. Physical activity among hospitalized older adults - an observational study. *BMC Geriatr*. 2017;17:110.
15. So C, Pierluissi E. Attitudes and expectations regarding exercise in the hospital of hospitalized older adults: a qualitative study. *J Am Geriatr Soc* 2012;60:713-8.
16. Hoogbeem T.J, Dronkers JJ, Hulzebos EH, van Meeteren NL. Merits of exercise therapy before and after major surgery. *Curr Opin Anaesthesiol*. 2014;27:161-6.
17. Hoogbeem T.J, van Meeteren NL, Schank K, Kim RH, Miner T, Stevens-Lapsley JE. Risk factors for delayed inpatient functional recovery after total knee arthroplasty. *Biomed Res Int*. 2015;2015:167643.
18. Lenssen AF, Crijns YH, Waltje EM, van Steyn MJ, Geesink RJ, van den Brandt PA, de Bie RA. Efficiency of immediate postoperative inpatient physical therapy following total knee arthroplasty: an RCT. *BMC Musculoskeletal Disord*. 2006;7:71.
19. Joosen P, Piette D, Buekers J, Taelman J, Berckmans D, De Boever P. A smartphone-based solution to monitor daily physical activity in a care home. *J Telemed Telecare*. 2019;25:611-22.
20. WHO. mHealth: New Horizons for health through mobile technologies; WHO: Geneva, Switzerland, 2011.
21. Ureña R, Chiclana F, Gonzalez-Alvarez A, Herrera-Viedma E, Moral-Munoz JA. m-SFT: A Novel Mobile Health System to Assess the Elderly Physical Condition. *Sensors* (Basel, Switzerland) 2020;20(5):1462.
22. Block VA, Pitsch E, Tahir P, Cree BA, Allen DD, Gelfand JM. Remote Physical Activity Monitoring in Neurological Disease: A Systematic Review. *PLoS One* 2016;11:e0154335,

23. Thijs I, Fresiello L, Oosterlinck W, Sinnaeve P, Rega F. Assessment of Physical Activity by Wearable Technology During Rehabilitation After Cardiac Surgery: Explorative Prospective Monocentric Observational Cohort Study. *JMIR mHealth uHealth* 2019;7:e9865.
24. Vandelanotte C, Muller AM, Short CE, Hingle M, Nathan N, Williams SL, Lopez ML, Parekh S, Maher, CA. Past, Present, and Future of eHealth and mHealth Research to Improve Physical Activity and Dietary Behaviors. *J Nutr Educ Behav*. 2016;48:219-28.
25. Coughlin SS, Whitehead M, Sheats JQ, Mastromonico J, Smith S. A Review of Smartphone Applications for Promoting Physical Activity. *Jacobs J Community Med*. 2016;2:1-14.
26. van der Weegen S, Verwey R, Spreeuwenberg M, Tange H, van der Weijden T, de Witte L. It's LiFe! Mobile and Web-Based Monitoring and Feedback Tool Embedded in Primary Care Increases Physical Activity: A Cluster Randomized Controlled Trial. *J Med Internet Res*. 2015;17:e184.
27. Feldman DI, Theodore Robison W, Pacor JM, Caddell LC, Feldman EB, Deitz RL, Feldman T, Martin SS, Nasir K, Blaha MJ. Harnessing mHealth technologies to increase physical activity and prevent cardiovascular disease. *Clin Cardiol*. 2018;41:985-91.
28. Ramkumar PN, Haerberle HS, Ramanathan D, Cantrell WA, Navarro SM, Mont MA, Bloomfield M, Patterson BM. Remote Patient Monitoring Using Mobile Health for Total Knee Arthroplasty: Validation of a Wearable and Machine Learning-Based Surveillance Platform. *J Arthroplasty*. 2019;34:2253-9.
29. Ramkumar PN, Haerberle HS, Bloomfield MR, Schaffer JL, Kamath AF, Patterson BM, Krebs VE. Artificial Intelligence and Arthroplasty at a Single Institution: Real-World Applications of Machine Learning to Big Data, Value-Based Care, Mobile Health, and Remote Patient Monitoring. *J Arthroplasty*. 2019;34:2204-9.
30. Correia FD, Nogueira A, Magalhães I, Guimarães J, Moreira M, Barradas I, Molinos M, Teixeira L, Tulha J, Seabra R, et al. Medium-Term Outcomes of Digital Versus Conventional Home-Based Rehabilitation After Total Knee Arthroplasty: Prospective, Parallel-Group Feasibility Study. *JMIR Rehabil Assist Technol*. 2019;6:e13111.
31. Dorje T, Zhao G, Scheer A, Tsokey L, Wang J, Chen Y, Tso K, Tan BK, Ge J, Maiorana A. SMARTphone and social media-based Cardiac Rehabilitation and Secondary Prevention (SMART-CR/SP) for patients with coronary heart disease in China: a randomised controlled trial protocol. *BMJ Open*. 2018; 8:e021908.
32. Chen KY, Janz KF, Zhu W, Brychta RJ. Redefining the roles of sensors in objective physical activity monitoring. *Med Sci Sports exerc* 2012;44:S13-23.
33. Evenson KR, Goto MM, Furberg RD. Systematic review of the validity and reliability of consumer-wearable activity trackers. *Int J Behav Nutr Phys Act*. 2015;12:159.
34. Bijmens WA, Stevens A, Ummels D, Meijer K. Optimization and Validation of an Adjustable Activity Classification Algorithm for Assessment of Physical Behavior in Elderly. *Sensors (Basel, Switzerland)*. 2019;19(24):5344.
35. Berendsen BA, Hendriks MR, Meijer K, Plasqui G, Schaper NC, Savelberg HH. Which activity monitor to use? Validity, reproducibility and user friendliness of three activity monitors. *BMC Public Health*. 2014; 14:749.
36. Annegarn J, Spruit MA, Uszko-Lencer NH, Vanbelle S, Savelberg HH, Schols AM, Wouters EF, Meijer K. Objective physical activity assessment in patients with chronic organ failure: a validation study of a new single-unit activity monitor. *Arch Phys Med Rehabil*. 2011;92:1852-1857.e1851.
37. Manas A, Del Pozo-Cruz B, Garcia-Garcia FJ, Guadalupe-Grau A, Ara I. Role of objectively measured sedentary behaviour in physical performance, frailty and mortality among older adults: A short systematic review. *Eur J Sport Sci*. 2017;17:940-53.
38. Shields RK, Enloe LJ, Evans RE, Smith KB, Steckel SD. Reliability, validity, and responsiveness of functional tests in patients with total joint replacement. *Phys Ther*. 1995;75:169-176; discussion 176-169.
39. Bercken VeVd. *Lineaire Regressieanalyse*, First edition ed.; Noordhoff Uitgevers bv: Groningen/Houten, the Netherlands, 2010.
40. Twisk JWR. *Inleiding in de toegepaste biostatistiek*, 2nd ed.; Elsevier Gezondheidszorg: Maarssen, 2010.
41. Fisher SR, Goodwin JS, Protas EJ, Kuo YF, Graham JE, Ottenbacher KJ, Ostir GV. Ambulatory activity of older adults hospitalized with acute medical illness. *J Am Geriatr Soc*. 2011;59:91-5.
42. Ostir GV, Berges IM, Kuo YF, Goodwin JS, Fisher SR, Guralnik JM. Mobility activity and its value as a prognostic indicator of survival in hospitalized older adults. *J Am Geriatr Soc*. 2013;61:551-7.

43. Brown CJ, Williams BR, Woodby LL, Davis LL, Allman RM. Barriers to mobility during hospitalization from the perspectives of older patients and their nurses and physicians. *J Hosp Med.* 2007;2:305-13.
44. Koenders N, van Oorsouw R, Seeger JPH, Nijhuis-van der Sanden MWG, van de Glind I, Hoogeboom T.J. "I'm not going to walk, just for the sake of walking...": a qualitative, phenomenological study on physical activity during hospital stay. *Disabil Rehabil* 2020;42(1):78-85.
45. Small SR, Bullock GS, Khalid S, Barker K, Trivella M, Price AJ. Current clinical utilisation of wearable motion sensors for the assessment of outcome following knee arthroplasty: a scoping review. *BMJ Open.* 2019;9:e033832.
46. Brønd JC, Arvidsson D. Sampling frequency affects the processing of Actigraph raw acceleration data to activity counts. *J Appl Physiol.* 2016;120:362-9.
47. Godfrey A, Hetherington V, Shum H, Bonato P, Lovell NH, Stuart S. From A to Z: Wearable technology explained. *Maturitas.* 2018;113:40-7.
48. Clark CCT, Nobre GC, Fernandes JFT, Moran J, Drury B, Mannini A, Gronek P, Podstawski R. Physical activity characterization: does one site fit all? *Physiol Meas.* 2018;39:09tr02.
49. Matthews CE, Hagströmer M, Pober DM, Bowles HR. Best practices for using physical activity monitors in population-based research. *Med Sci Sports Exerc.* 2012;44:S68-76.
50. Schotanus MGM, Bemelmans YFL, Grimm B, Heyligers IC, Kort NP. Physical activity after outpatient surgery and enhanced recovery for total knee arthroplasty. *Knee Surg Sports Traumatol Arthrosc.* 2017;25:3366-71.
51. Fenten MGE, Bakker SMK, Scheffer GJ, Wymenga AB, Stienstra R, Heesterbeek,PJC. Femoral nerve catheter vs local infiltration for analgesia in fast track total knee arthroplasty: short-term and long-term outcomes. *Br J Anaesth.* 2018;121:850-8.
52. Luna IE, Kehlet H, Wede HR, Hoevsgaard SJ, Aasvang EK. Objectively measured early physical activity after total hip or knee arthroplasty. *J Clin Monit Comput.* 2019;33:509-22.
53. Krenk L, Jennum P, Kehlet H. Activity, sleep and cognition after fast-track hip or knee arthroplasty. *J Arthroplasty.* 2013;28:1265-9.
54. Tsuji S, Tomita T, Fujii M, Laskin RS, Yoshikawa H, Sugamoto K. Is minimally invasive surgery-total knee arthroplasty truly less invasive than standard total knee arthroplasty? A quantitative evaluation. *J Arthroplasty.* 2010;25:970-6.
55. Hayashi K, Kako M, Suzuki K, Takagi Y, Terai C, Yasuda S, Kadono I, Seki T, Hiraiwa H, Ushida T, et al. Impact of variation in physical activity after total joint replacement. *J Pain Res.* 2018;11:2399-406.
56. Twiggs J, Salmon L, Kolos E, Bogue E, Miles B, Roe J. Measurement of physical activity in the pre- and early post-operative period after total knee arthroplasty for Osteoarthritis using a Fitbit Flex device. *Med Eng Phys.* 2018;51:31-40.
57. Bassett DR, John D. Use of pedometers and accelerometers in clinical populations: validity and reliability issues. *Phys Ther Rev.* 2010;15:135-42.
58. Peel NM, Kuys SS, Klein K. Gait speed as a measure in geriatric assessment in clinical settings: a systematic review. *J Gerontol A Biol Sci Med Sci.* 2013;68:39-46.
59. Floegel TA, Florez-Pregonero A, Hekler EB, Buman MP. Validation of Consumer-Based Hip and Wrist Activity Monitors in Older Adults With Varied Ambulatory Abilities. *J Gerontol A Biol Sci Med Sci.* 2017; 72:229-36.
60. Beevi FH, Miranda J, Pedersen CF, Wagner S. An Evaluation of Commercial Pedometers for Monitoring Slow Walking Speed Populations. *Telemed J E Health.* 2016;22:441-9.
61. Martin JB, Krč KM, Mitchell EA, Eng JJ, Noble JW. Pedometer accuracy in slow walking older adults. *Int J Ther Rehabil.* 2012;19:387-93.
62. Cyarto EV, Myers A, Tudor-Locke C. Pedometer accuracy in nursing home and community-dwelling older adults. *Med Sci Sports Exerc.* 2004;36:205-9.
63. Argent R, Slevin P, Bevilacqua A, Neligan M, Daly A, Caulfield B. Clinician perceptions of a prototype wearable exercise biofeedback system for orthopaedic rehabilitation: a qualitative exploration. *BMJ Open.* 2018;8:e026326.
64. Argent R, Slevin P, Bevilacqua A, Neligan M, Daly A, Caulfield B. Wearable Sensor-Based Exercise Biofeedback for Orthopaedic Rehabilitation: A Mixed Methods User Evaluation of a Prototype System. *Sensors (Basel, Switzerland)* 2019;19(2):432.
65. Kayaalp ME, Agres AN, Reichmann J, Bashkuev M, Duda GN, Becker R. Validation of a Novel Device for the Knee Monitoring of Orthopaedic Patients. *Sensors (Basel, Switzerland)* 2019;19:5193.

66. Brennan L, Dorrnoro Zubiete E, Caulfield B. Feedback Design in Targeted Exercise Digital Biofeedback Systems for Home Rehabilitation: A Scoping Review. *Sensors (Basel, Switzerland)* 2019; 20(1):181.
67. Bell KM, Onyeukwu C, McClincy MP, Allen M, Bechard L, Mukherjee A, Hartman RA, Smith C, Lynch AD, Irrgang JJ. Verification of a Portable Motion Tracking System for Remote Management of Physical Rehabilitation of the Knee. *Sensors (Basel, Switzerland)* 2019;19:1021.
68. Chiang CY, Chen KH, Liu KC, Hsu SJ, Chan CT. Data Collection and Analysis Using Wearable Sensors for Monitoring Knee Range of Motion after Total Knee Arthroplasty. *Sensors (Basel, Switzerland)* 2017;17:418.
69. Msayib Y, Gaydecki P, Callaghan M, Dale N, Ismail S. An Intelligent Remote Monitoring System for Total Knee Arthroplasty Patients. *J Med Syst.* 2017;41:90.
70. O'Reilly M, Caulfield B, Ward T, Johnston W, Doherty C. Wearable Inertial Sensor Systems for Lower Limb Exercise Detection and Evaluation: A Systematic Review. *Sports Med (Auckland, N.Z.)* 2018;48: 1221-46.
71. Peake JM, Kerr G, Sullivan JP. A Critical Review of Consumer Wearables, Mobile Applications, and Equipment for Providing Biofeedback, Monitoring Stress, and Sleep in Physically Active Populations. *Front Physiol.* 2018;9:743.

CHAPTER SIX

OPTIMIZATION AND VALIDATION OF A CLASSIFICATION ALGORITHM FOR ASSESSMENT OF PHYSICAL ACTIVITY IN HOSPITALIZED PATIENTS

Hanneke C. van Dijk-Huisman*

Wouter Bijmens*

Rachel Senden

Johannes M.N. Essers

Kenneth Meijer

Jos Aarts

Antoine F. Lenssen

* Shared first authorship.

Published in Sensors 2021;21:1652

Digital Object Identifier: 10.3390/s21051652

ABSTRACT

Background

Low amounts of physical activity (PA) and prolonged periods of sedentary activity are common in hospitalized patients. Objective PA monitoring is needed to prevent the negative effects of inactivity, but a suitable algorithm is lacking. The aim of this study is to optimize and validate a classification algorithm that discriminates between sedentary, standing, and dynamic activities, and records postural transitions in hospitalized patients under free-living conditions.

Methods

Optimization and validation in comparison to video analysis were performed in orthopedic and acutely hospitalized elderly patients with an accelerometer worn on the upper leg. Data segmentation window size (WS), amount of PA threshold (PA Th) and sensor orientation threshold (SO Th) were optimized in 25 patients, validation was performed in another 25. Sensitivity, specificity, accuracy, and (absolute) percentage error were used to assess the algorithm's performance.

Results

Optimization resulted in the best performance with parameter settings: WS 4 s, PA Th 4.3 counts per second, SO Th 0.8 g. Validation showed that all activities were classified within acceptable limits (>80% sensitivity, specificity and accuracy, $\pm 10\%$ error), except for the classification of standing activity.

Conclusions

As patients need to increase their PA and interrupt sedentary behavior, the algorithm is suitable for classifying PA in hospitalized patients.

INTRODUCTION

Low amounts of physical activity (PA) and prolonged periods of uninterrupted sedentary activity are common in hospitalized patients. Patients spend between 87 and 100% of their day lying in bed or sitting in a chair¹⁻⁵. Little time is spent being active, and bouts of standing and walking are usually short^{6,7}. This sedentary behavior is found in all patient subpopulations. On average, surgical inpatients spend 10 to 71 min per day standing and walking^{1,8-10}, compared to 66 to 117 min for geriatric inpatients^{7,11-13}, 1 to 184 min for medical inpatients¹⁴⁻²⁰, 10 to 86 min for post-stroke inpatients²¹⁻²⁶, and 0 min for patients admitted to the intensive care unit^{27,28}.

Low amounts of PA and prolonged periods of uninterrupted sedentary activity during hospitalization have been associated with functional decline^{29,30}, a decline in physical performance³⁰, increased insulin resistance³⁰, increased length of stay³¹, increased risk of institutionalization¹⁶, and mortality^{29,32-34}. To reduce the risks of these negative effects, interventions aimed at increasing the amounts of PA and breaking up prolonged periods of sedentary activity are essential^{30,35-39}. In order to support (i.e., perform and/or evaluate) such interventions, it is necessary to measure patients' PA behavior in an objective and accurate way^{2,40,41}.

Monitoring patients' PA behavior during hospitalization is commonly performed using self-reported measures, behavior mapping, or wearable activity monitors^{1,2,40,42}. Self-reported measures (e.g., surveys or diaries) are subjective and show low validity and reliability^{40,42,43}. Behavior mapping involves direct, structured observation and classification of patients' PA behavior by observers^{44,45}. This is labor-intensive and may intrude upon patients' privacy^{41,46}. Moreover, it may under- or overestimate amounts of PA and periods of uninterrupted sedentary activity when observations are performed during daytime hours only, or when sampled at brief intervals (e.g., one minute in every ten minutes)^{16,41,46-48}. As bouts of walking often last less than two minutes, they might not be recorded, resulting in an underestimation of the amount of PA. Wearable activity monitors, such as accelerometers, allow for objective, continuous quantification and classification of patients' PA behavior over longer time periods, with minimal effort and invasiveness^{1,2,6,41,49,50}. Despite all their advantages, accelerometers have not been widely integrated in clinical practice, due to issues relating to feasibility, reliability, and validity^{2,41,50}. Accelerometers measure raw accelerations obtained from movements of a body or a body segment. PA behavior is then estimated by applying an algorithm to the raw data⁵¹. Most algorithms are built with the same conceptual building blocks, viz., (1) a pre-processing phase to remove artifacts from the raw data, (2) data segmentation, (3) extraction of data features, and (4) a classifier that translates the raw data into interpretable outcome measures⁵²⁻⁵⁷.

The performance metrics of an algorithm to measure patients' PA behavior are influenced by patient characteristics (e.g., age, walking speed, gait pattern, and the use of a walking aid), sensor wear location, number of sensors used, and outcome parameters (e.g., classifying activities, step count, and intensity)^{41,42}. Time spent in dynamic activities (e.g., walking, stair climbing) and the classification of postural transitions from sedentary to upright position are the most relevant outcome parameters for hospitalized patients, as they need to increase their amount of PA and interrupt prolonged periods of sedentary activity^{1,35,45}. Most accelerometer algorithms are validated in healthy adults and lack the sensitivity to classify slow or impaired gait^{58,59}. They are not able to accurately differentiate slow gait and shuffling from standing. However, slow and impaired gait, as well as the frequent use of walking aids, are common in hospitalized patients. As a result, using an algorithm that is validated in healthy adults in a population of hospitalized patients would require optimization and validation of the algorithm's performance⁴¹. Previous studies have shown that the validity of existing algorithms to discriminate between sedentary, standing, and dynamic activities, and to classify postural transitions in hospitalized patients, varies and is usually investigated in small study samples^{12,35,45,46,48,55,60-62}. A suitable algorithm for hospitalized patients that is able to discriminate between standing and dynamic activities, as well as to classify postural transitions, is currently lacking⁶³.

Recently, Hospital Fit (HFITAPP0, Maastricht Instruments B.V., Maastricht, The Netherlands), a smartphone application connected to an accelerometer, was developed to enable PA monitoring and to stimulate recovery in hospitalized patients¹. The algorithm embedded in this accelerometer is able to differentiate time spent being sedentary (lying/sitting) from time spent being active (standing/dynamic) in hospitalized patients. The current study is built upon Hospital Fit by aiming to discriminate between standing and dynamic activities and by classifying postural transitions. Bijnens et al. have presented an adjustable PA classification algorithm that is validated to discriminate between sedentary, standing, and dynamic activities in healthy elderly persons⁴⁹. Its easily adjustable parameters enable the performance of this algorithm to be optimized for different target populations and sensor wear locations. The algorithm had not yet been optimized or validated in hospitalized patients. Doing so and implementing the proposed algorithm in Hospital Fit would improve PA monitoring in hospitalized patients. The aim of this study was therefore to optimize and validate a PA classification algorithm which is able to discriminate between sedentary, standing, and dynamic activities, and to detect postural transitions among hospitalized patients. We assessed the concurrent validity of the algorithm to classify sedentary, standing, and dynamic activities and detect postural transitions in hospitalized patients, by checking it against video analysis.

MATERIALS AND METHODS

Study design

This single-center, prospective validation study was conducted at Maastricht University Medical Center (MUMC+) in Maastricht, The Netherlands, between November 2019 and March 2020.

Study population

Patients who received physical therapy and were (1) admitted for elective total knee arthroplasty (TKA) or total hip arthroplasty (THA) at the Department of Orthopedic Surgery and Traumatology, or (2) aged 70 years or older and acutely hospitalized at the Department of Internal and Geriatric Medicine at the MUMC+ were invited to participate. Patients were recruited during weekdays. Patients scheduled for elective TKA or THA received verbal and written information about the study from their physical therapist four to six weeks prior to surgery, during preoperative screening. A researcher contacted the patients during their hospitalization, and written informed consent was obtained before they entered the study. Acutely hospitalized elderly patients received verbal and written information about the study from their physical therapist during their first physical therapy session. Informing these patients prior to hospitalization was not possible because they were admitted acutely. A researcher contacted the patients the next day. If patients were interested in participating, an informed consent form was provided by the researcher and written informed consent was obtained before they entered the study. Informed consent was signed in the patient's own room. Confidential processing of data and anonymity were guaranteed.

Patients were eligible if they met the following inclusion criteria: receiving physical therapy, aged 18 years or older and admitted for TKA or THA at the Department of Orthopedic Surgery and Traumatology, or aged 70 years or older and acutely admitted at the Department of Internal and Geriatric Medicine, having been able to walk independently two weeks prior to admission as scored on the Functional Ambulation Categories (FAC >3)⁶⁴, and having a sufficient understanding of the Dutch language. Exclusion criteria were: the presence of contraindications to walking or wearing an accelerometer on the upper leg, admission to the intensive care unit, impaired cognition (delirium / dementia) or being incapacitated as reported by the attending doctor, a life expectancy of less than three months, and previous participation in this study.

This study was performed in compliance with the Declaration of Helsinki and was approved by the Medical Ethics Committee of the University Hospital Maastricht and Maastricht University (METC azM/UM), registration number 2019-1265.

Data collection

Fifty patients were enrolled after signing the informed consent. The sample size of 50 corresponds to that used in previous validation studies, which included 8 to 99 participants^{35,42,46,62,65-70}. Optimization of the adjustable algorithm described by Bijmens et al. was performed on data of 25 patients⁴⁹. Validation of the optimized algorithm was then performed on data of the remaining 25 patients. After inclusion, patients were randomized 1:1 to the optimization or validation group, using a stratified block randomization. To ensure an equal distribution of orthopedic and elderly patients within the optimization and validation groups, patients were first stratified by department ('Orthopaedic Surgery and Traumatology' or 'Internal and Geriatric Medicine') before they were randomized (Figure 6.1). The randomization and allocation of patients was carried out by an independent researcher. The randomization schedule was created using a computer-based random number generator. Medical and demographic data (age, sex, and use of a walking aid) were extracted from the electronic patient records. Missing data were not substituted and drop-outs were not replaced.

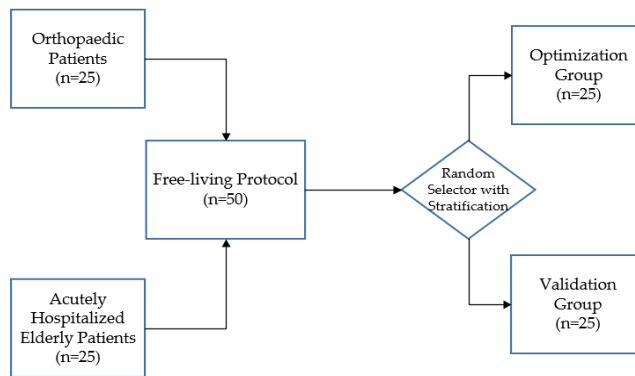

Figure 6.1 After stratification according to department, 50 patients were randomly assigned to the optimization or validation group.

All patients received a referral to usual care physical therapy from their physician. As physical therapy sessions often comprise a significant part of the patients' PA behavior during their hospital stay, a randomly selected physical therapy session was used to collect data under free-living conditions. This could range from the first to the last physical therapy session, which enabled the performance of the algorithm to be investigated in a variety of patients with different gait patterns. Physical therapy sessions were aimed at increasing PA and stimulating functional recovery of activities of daily living which are essential in order to function independently at home. Sedentary, standing, and dynamic activities (e.g., walking, stair climbing) as well as postural transitions from sedentary (sitting/lying) to

upright (standing/dynamic) positions were performed at least once during each physical therapy session. The exact content of physical therapy sessions depended on the diagnosis and needs of the individual patients. The order, pace, and duration of activities varied between individuals. If necessary, patients used a walking aid. This study did not interfere with the content of the physical therapy sessions.

Video recordings

Patients were recorded from the waist down using a handheld camera (HDC-HS60, Panasonic, Osaka, Japan). Recording the faces or other people within the hospital wards was avoided. The video recordings served as a reference for the classification of sedentary, standing, and dynamic activities, as well as for the detection of postural transitions. Video recording was used as the gold standard in activity monitoring, as it allows the most accurate activity classification, and offers the possibility to reanalyze data by single or multiple observers⁷¹⁻⁷³. After the physical therapy session, the video recordings were uploaded to a computer.

Acceleration data

Acceleration data were acquired with a MOX Activity Logger (MOX; Maastricht Instruments, Maastricht, The Netherlands (Figure 6.2A)). The MOX contains a tri-axial accelerometer sensor (ADXL362; Analog Devices, Norwood, MA, USA). The small, lightweight, waterproof device (35 × 35 × 10 mm, 11 g) measures raw acceleration data (±8 g) for three orthogonal sensor axes (X, Y, and Z) at a 25 HZ sampling rate, and stores the data directly in its internal memory. Each axis is factory-calibrated against gravity. The MOX is capable of measuring and storing data continuously for up to seven days. Data analysis is performed offline. After uploading the raw acceleration data provided by the MOX to a computer, an algorithm can be applied to these raw data. The MOX has been successfully used as an activity logger for PA monitoring in colorectal cancer survivors, chronic organ failure patients, total knee and hip arthroplasty patients, and healthy elderly subjects^{1,40,49,74,75}.

The MOX uses a custom-made, double-sided, waterproof, hypoallergenic patch for body attachment. Prior to the physical therapy session, this patch was used to attach the MOX to the upper leg (ten centimeters proximal of the patella, Figure 6.2B). The upper leg location was chosen as it allows for classification of body postures and movements (e.g., lying/sitting, standing, walking)⁷⁶⁻⁷⁸. For the orthopedic patients, the MOX was attached to the non-operated leg. For the acutely hospitalized elderly patients, the MOX was attached to the right leg. Both at the beginning and the end of the physical therapy session, the researcher tapped the MOX twice for the purpose of post-hoc synchronization between the video recording and the raw acceleration data. After the treatment session, the MOX was removed and the raw acceleration data were uploaded to a computer via a USB connection.

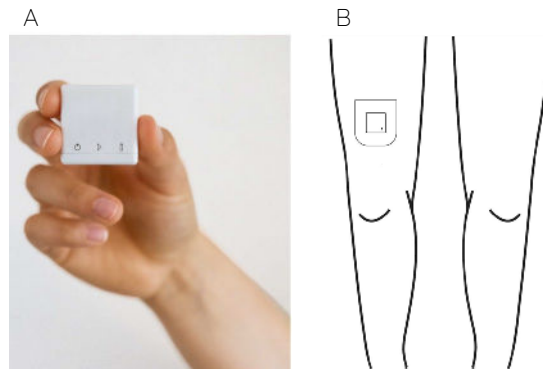

Figure 6.2 The MOX activity logger (A) and the wear location on the upper leg (B).

Data analysis

Video recordings

All video recordings were continuously classified as (1) sedentary, (2) standing, or (3) dynamic activities using the Behavioral Observation Research Software (BORIS, v7.9.19)⁷⁹. Postural transitions were recorded when a sedentary activity was followed by a standing or dynamic activity. Three trained observers (R.S., H.C.v.D.-H., J.M.N.E.) were given clear definitions to classify each activity or transition (Table 6.1).

Each video recording was independently analyzed by two observers. In order to minimize bias, different combinations of observers were used. Observers were blinded to the classifications made by other observers and by the algorithm. Using video recordings as a gold standard requires high inter-observer reliability. This was assessed based on the total time per activity per patient, using the intraclass correlation coefficient (ICC, two-way random, absolute agreement). An ICC ≥ 0.9 was considered high⁸⁰.

Table 6.1 Definitions for activity classification of the video recordings.

Activity	Definition
Sedentary	Patient is in a seated or lying position (angle between upper leg and gravity vector < 60 degrees)
Standing	Patient is in an upright position (angle between upper leg and gravity vector > 60 degrees) for more than 2 s without activity of the lower extremities
Dynamic	Patient performs physical activity with the lower extremities for at least 2 s, such as walking, stair climbing, or cycling
Postural Transitions	Transition from a sedentary activity to a standing or dynamic activity

Algorithm optimization

The adjustable classification algorithm previously described by Bijmens et al.⁴⁹ was used as the starting point for the optimization process. This algorithm contains three parameters that can be easily adjusted for target population and sensor wear location: (1) data segmentation window size (WS), (2) amount of physical activity threshold (PA Th), and (3) sensor orientation threshold (SO Th). The algorithm was recently validated to discriminate between sedentary, standing, and dynamic activities in healthy elderly persons with an upper leg wear location. The parameter settings of this algorithm were referred to as MOXAL (WS: 2 s, PA Th: 7 counts per second (cps), SO Th: 0.8 g)⁴⁹.

To determine the performance of MOXAL in hospitalized patients with an upper leg wear location, we applied it to the raw acceleration data of our optimization group. MATLAB (R2018b; The MathWorks Inc., Natick, MA, USA) was used to convert the raw acceleration data into classifications of sedentary, standing, or dynamic activities for each data segmentation window.

The classification accuracy of the algorithm was assessed by calculating sensitivity, specificity, and accuracy for each activity⁸¹. The acceleration data were manually synchronized with the data of the video recordings. Data of the video recordings were segmented into windows of similar length as the algorithm's data segmentation window size, in order for it to be used as a reference. The main activity within each window was used as a comparator. For each individual, activity classifications derived from MOXAL were compared with classifications derived from the video recordings in a confusion matrix. Comparisons were made for each window within the entire measurement period. The confusion matrix showed how often activity classifications were detected correctly by the algorithm in comparison with the video classifications, and how often activities were classified differently. Confusion matrices were derived for sedentary, standing, and dynamic activities as described by Ruuska et al.⁸¹. Figure 6.3 provides an example of a confusion matrix for dynamic activity. To assess the performance accuracy for postural transitions, a synchronized time array was created for the annotated video data and algorithm classifications, in order to create a confusion matrix. In this time array, a sedentary window followed by a standing or dynamic window was given the value "one," whereas adjacent windows of the same activity were given the value "zero." Sensitivity, specificity, and accuracy were subsequently calculated per activity and for postural transitions (Equations (A1)–(A3))⁸¹. Additionally, the classification accuracy was calculated over all activities (total), based on the sum of the confusion matrices of the separate activities.

Activity classification algorithm

		Dynamic	Not Dynamic
Video recordings	Dynamic	(TP)	(FN)
	Not Dynamic	(FP)	(TN)

Figure 6.3 Binary confusion matrix for the classification of dynamic activities per patient. True positive (TP) = number of windows correctly classified by the algorithm as dynamic; false positive (FP) = number of windows incorrectly classified as dynamic; true negative (TN) = number of windows correctly classified as not dynamic, and false negative (FN) = number of windows incorrectly classified as not dynamic.

To assess the classification error of the algorithm, percentage error (PE) and absolute percentage error (APE) were calculated per activity (Equations (A4) and (A5))⁴⁹. PE and APE reflect the error between the video recordings and the algorithm, and were assessed based on the total time per activity as classified by the video recordings. To assess the error of postural transitions, the total numbers of postural transitions determined by the video classifications and the algorithm were compared. A negative PE value reflects an overestimation by the algorithm, while a positive PE value reflects an underestimation. APE does not differentiate between over- or underestimation, and thus provides an indication of the magnitude of the error. As PE and APE are relative measures, it is possible to compare them across studies⁵¹. Additionally, the errors over all activities (total) were calculated as the sum of the errors of the separate activities.

All performance metrics of the classification accuracy and error were determined for each individual, and medians (Q1 to Q3) were calculated per group. The median and interquartile ranges were used to present non-normally distributed data. Sensitivity, specificity, and accuracy values of 80% or higher were considered acceptable^{71,82}. PE \pm 10% and APE lower than 10% were considered to be within acceptable limits^{83,84}.

During the optimization phase, the parameter settings of MOXAL (WS, PA Th, and SO Th) were adjusted to reduce the total activity APE. Out of a set of 4025 combinations (WS ranging from 0.4 s to 10 s in steps of 0.4 s, PA Th ranging from 2 cps to 6 cps in steps of 0.025 cps), the parameter settings resulting in the lowest total activity APE were referred to as MOXAL_{opt} (WS: 0.8 s, PA Th: 3.85 cps, SO Th: 0.8 g). The performance metrics (sensitivity, specificity, accuracy, PE, and APE) of MOXAL_{opt} were assessed in the same way as for MOXAL. As the optimization did not

sufficiently improve the performance of the algorithm, additional modifications had to be introduced.

Since the amount of PA for dynamic activity was very low for the hospitalized patients, there was a relatively small difference in the amount of PA between standing and dynamic activities. This small difference made it challenging to find an appropriate PA Th. Therefore, additional modifications were introduced regarding the decision tree and the calculation of the amount of PA. The decision tree was modified to first discriminate between sedentary and upright windows based on the SO Th. Next, the upright windows were further classified as standing or dynamic activity based on the PA Th. Furthermore, in MOXAL and MOXAL_{opt}, the amount of PA was calculated by combining the raw acceleration data of the three orthogonal sensor axes. In the modified algorithm, only the most sensitive axis was used, to avoid masking effects of other axes and improve the calculation of the amount of PA. Walking produces a distinct pattern in both anterior-posterior and vertical directions. In patients who walk slowly, especially those using walking aids, the anterior-posterior acceleration signal is more pronounced than the vertical acceleration signal⁵⁵. Using the anterior-posterior axis was therefore expected to improve the calculation of the amount of PA in hospitalized patients and consequently improve the classification of standing and dynamic activities.

After these modifications, the algorithm was optimized again by adjusting the parameter settings. Using the same 4025 combinations as before, the parameter settings resulting in the lowest total APE were referred to as HFITAL (WS: 4 s, PA Th: 4.3 cps, SO Th: 0.8 g). Next, the performance metrics of HFITAL were assessed in the same way as for MOXAL. A schematic overview of the data processing of HFITAL is shown in Figure A6.1.

Algorithm validation

After the algorithm had been optimized, it was validated by assessing the performance of the optimized algorithm in a different group of patients within the same target population. Data of the validation group were used to assess the performance metrics of HFITAL as regards classifying sedentary, standing, and dynamic activities and detecting postural transitions in hospitalized patients in comparison to the video analysis. The performance metrics (sensitivity, specificity, and accuracy, PE, and APE) were calculated in the same way as described above for the algorithm optimization. In addition, a subgroup analysis was performed in which the performance metrics were assessed for acutely hospitalized elderly patients and orthopedic patients separately, providing more insight into the performance of the algorithm in the two groups.

RESULTS

Participant characteristics

Of the 50 participating patients, four (8.0%) were excluded due to problems with synchronization or technical complications. This resulted in 46 (92.0%) patients for analysis, with 22 (47.8%) in the optimization group and 24 (52.2%) in the validation group. The baseline characteristics of patients included in the optimization and validation groups are reported in Table 6.2.

Inter-observer reliability

The inter-observer reliability of the classification of activities based on the video recordings was high. The ICC values for the optimization group were 1.000, 0.994, and 0.995 for sedentary, standing, and dynamic activities, respectively. The ICC values for the validation group were 1.000 for sedentary and dynamic activities, and 0.997 for standing activity.

Table 6.2 Characteristics of study participants in the optimization and validation groups.

Characteristic	Optimization Group			Validation Group		
	All Patients (n=22)	Acutely Hospitalized Elderly Patients (n=11)	Orthopedic Patients (n=11)	All Patients (n=24)	Acutely Hospitalized Elderly Patients (n=12)	Orthopedic Patients (n=12)
Sex, female (n, %)	7 (31.8%)	2 (18.2%)	5 (45.5%)	14 (58.3%)	7 (58.3%)	7 (58.3%)
Age, years (median, Q1 to Q3)	75.4 (72.6 to 82.0)	82.0 (75.4 to 87.7)	73.7 (66.4 to 76.0)	75.8 (70.3 to 85.5)	84.7 (77.0 to 88.3)	70.1 (61.2 to 75.5)
Walking Aid (n, %)	20 (90.9%)	11 (100.0%)	9 (81.8%)	21 (87.5%)	12 (100.0%)	9 (75.0%)

Algorithm optimization

The median (Q1 to Q3) duration of the measurement protocol for patients in the optimization group was 12.3 (8.3 to 15.0) minutes per patient. The median (Q1 to Q3) times spent performing sedentary and standing activities were 3.0 (0.7 to 7.4) and 2.1 (1.5 to 3.9) minutes per patient, respectively. The majority of time was spent performing dynamic activity, with a median (Q1 to Q3) time of 4.9 (3.9 to 6.5) minutes per patient.

Applying MOXAL to the acceleration data of the optimization group resulted in the performance metrics shown in Table 6.3 and Figure 6.4. All performance metrics are expressed as median percentages (Q1 to Q3). MOXAL resulted in a low sensitivity of 79.0% (40.1% to 92.9%) and a high APE of 18.2% (3.4% to 55.4%) for the classification of dynamic activity, as well as a high PE of -33.1% (-114.8% to 1.1%) and an APE of

34.0% (6.1% to 114.8%) for the classification of standing activity. Total APE was 18.9% (4.2% to 51.0%).

Applying MOXAL_{Opt} to the data of the optimization group resulted in a low sensitivity of 74.5% (42.3% to 88.0%) for the classification of dynamic activity and high PE values of 10.4% (6.1% to 17.4%), -42.9% (-106.8% to 1.4%), and -200.0% (-290% to -150%) for the classification of sedentary activities, standing activities, and postural transitions, respectively. None of the APE values fell within the acceptable limits. Total APE was 11.8% (8.7% to 56.0%). Since the performance metrics of MOXAL_{Opt} did not improve compared to MOXAL (in some cases they even deteriorated), additional modifications were introduced to the algorithm, resulting in the optimized algorithm HFITAL.

Applying HFITAL to the acceleration data of the optimization group resulted in acceptable performance metrics, for both the classification of sedentary, dynamic, and total activities, and for the detection of postural transitions. Only the sensitivity of 67.3% (57.1% to 76.4%), the PE of 20.2% (-10.1% to 30.5%), and the APE of 25.1% (11.8% to 35.5%) for the classification of standing activity did not fall within the acceptable limits. Total APE was 7.6% (4.8% to 15.3%).

A detailed overview of the parameter settings of the activity classification algorithms evaluated during the optimization process, and a schematic overview of the data processing of HFITAL, can be found in Table A6.1 and Figure A6.1. A graphical representation of the raw acceleration data, the video annotations, and the classification by MOXAL, MOXAL_{Opt}, HFITAL is given as an example in Figure A6.2. Detailed numeric results can be found in supplementary material Spreadsheet S1: S1_OptimizationResults.xlsx.

Table 6.3 Median values (Q1 to Q3) of the performance metrics (% sensitivity, specificity, accuracy, PE, and APE) of the classification of activities by MOXAL, MOXAL_{Opt}, and HFITAL within the optimization group (n=22).

Activity	Algorithm	Sensitivity (%)	Specificity (%)	Accuracy (%)	PE (%)	APE (%)
Sedentary	MOXAL	95.6 (88.3 to 98.0)	99.1 (98.1 to 99.6)	98.5 (97.4 to 98.9)	2.6 (0.5 to 8.7)	3.2 (1.0 to 11.4)
	MOXAL _{Opt}	88.0 (79.5 to 93.3)	99.0 (99.0 to 100.0)	96.0 (96.0 to 97.0)	10.4 (6.1 to 17.4)	10.4 (6.1 to 17.4)
	HFITAL	97.7 (96.2 to 100.0)	97.1 (95.2 to 99.2)	97.5 (95.3 to 98.9)	-2.1 (-4.4 to 3.6)	3.8 (2.3 to 7.2)
Standing	MOXAL	87.4 (79.9 to 93.1)	89.4 (64.4 to 97.3)	88.8 (71.6 to 94.4)	-33.1 (-114.8 to 1.1)	34.0 (6.1 to 114.8)
	MOXAL _{Opt}	84.0 (76.3 to 88.8)	87.5 (59.0 to 93.0)	86.0 (66.3 to 90.3)	-42.9 (-106.8 to 1.4)	42.9 (8.0 to 106.8)
	HFITAL	67.3 (57.1 to 76.4)	96.8 (90.5 to 98.9)	90.3 (87.3 to 92.5)	20.2 (-10.1 to 30.5)	25.1 (11.8 to 35.5)
Dynamic	MOXAL	79.0 (40.1 to 92.9)	96.1 (90.2 to 97.5)	84.1 (72.3 to 94.6)	8.8 (-2.6 to 55.4)	18.2 (3.4 to 55.4)
	MOXAL _{Opt}	74.5 (42.3 to 88.0)	89.5 (84.8 to 94.0)	84.5 (63.4 to 89.0)	8.7 (-9.0 to 50.7)	17.5 (8.7 to 56.0)
	HFITAL	93.6 (85.9 to 96.2)	92.2 (84.4 to 94.9)	90.9 (86.5 to 94.2)	-3.2 (-8.2 to 4.7)	6.9 (3.1 to 16.8)
Total	MOXAL	83.2 (71.0 to 93.8)	91.6 (85.5 to 96.9)	88.8 (80.7 to 95.8)	0.1 (-0.1 to 0.3)	18.9 (4.2 to 51.0)
	MOXAL _{Opt}	82.9 (62.9 to 87.3)	91.4 (81.5 to 93.6)	88.6 (75.3 to 91.5)	-0.1 (-0.1 to 0.1)	11.8 (8.7 to 56.0)
	HFITAL	89.7 (86.1 to 91.5)	94.8 (93.1 to 95.7)	93.1 (90.7 to 94.3)	0.2 (-0.1 to 0.4)	7.6 (4.8 to 15.3)
Postural	MOXAL	100.0	100.0	100.0	0.0	0.0
Transitions	MOXAL	100.0 (100.0 to 100.0)	100.0 (100.0 to 100.0)	100.0 (100.0 to 100)	0.0 (0.0 to 0.0)	0.0 (0.0 to 19.0)
	MOXAL _{Opt}	100.0 (100.0 to 100.0)	96.1 (93.6 to 98.1)	96.2 (93.8 to 98.1)	-200.0 (-290.0 to -150.0)	200.0 (150.0 to 190.0)
	HFITAL	100.0 (100.0 to 100.0)	100.0 (100.0 to 100.0)	100.0 (100.0 to 100.0)	0.0 (0.0 to 0.0)	0.0 (0.0 to 13.0)

PE = percentage error. APE = absolute percentage error. MOXAL = adjustable classification algorithm validated in community-dwelling healthy elderly persons with an upper leg wear location, used as the starting point for the optimization process. MOXAL_{Opt} = classification algorithm after optimization of three adjustable parameter settings of MOXAL to reduce absolute percentage error for total activity. HFITAL = classification algorithm after additional modifications were introduced to MOXAL regarding the decision tree and the calculation of the amount of physical activity.

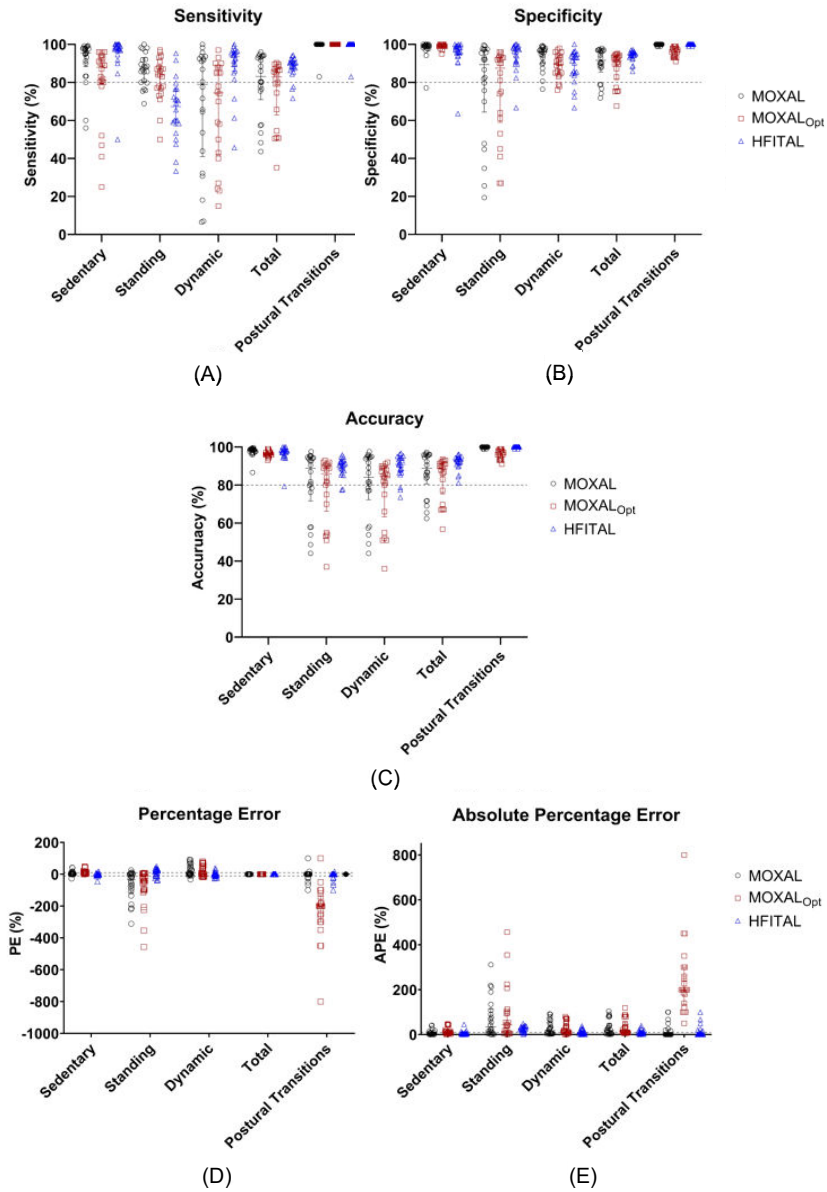

Figure 6.4 Performance metrics (% Sensitivity (A), specificity (B), accuracy (C), percentage error (D), and absolute percentage error (E)) of the classification of activities by MOXAL, MOXAL_{Opt}, and HFITAL within the optimization group. All individual values are shown. Acceptable limits are represented by dashed lines. MOXAL is represented in black, MOXAL_{Opt} in brown, and HFITAL in blue. (MOXAL = adjustable classification algorithm validated in community-dwelling healthy elderly persons with an upper leg wear location, used as the starting point for the optimization process. MOXAL_{Opt} = classification algorithm after optimization of three adjustable parameter settings of MOXAL to reduce the absolute percentage error for total activity. HFITAL = classification algorithm after additional modifications were introduced to MOXAL regarding the decision tree and the calculation of the amount of physical activity).

Algorithm validation

The median (Q1 to Q3) duration of the measurement protocol for patients included in the validation group was 10.8 (7.4 to 18.4) minutes per patient. The median (Q1 to Q3) times spent performing sedentary and standing activities were 3.7 (1.8 to 6.3) and 1.9 (0.4 to 4.6) minutes per patient, respectively. The majority of time was spent performing dynamic activity, with a median (Q1 to Q3) time of 4.4 (3.8 to 7.5) minutes per patient.

Validation of the optimized algorithm was performed by applying HFITAL to the acceleration data of the validation group. This resulted in the performance metrics shown in Table 6.4 and Figure 6.5. The classification of activities and the detection of postural transitions produced sensitivity, specificity, and accuracy values above 89.2%, while APE and PE values were below 8.6%. Postural transitions were accurately detected by the algorithm, showing an identical number of transitions for 76% of the patients. In one patient, HFITAL overestimated the number of transitions by two. In four patients, HFITAL overestimated the number of transitions by one. With a sensitivity of 65.0% (34.1% to 76.9%), a PE of 21.3% (-3.9% to 50.2%) and an APE of 29.2% (14.6% to 55.2%), the classification of standing activity did not meet the acceptable limits.

Subgroup analysis of the data of the acutely hospitalized elderly patients resulted in sensitivity, specificity, and accuracy values above 88.6%, and APE and PE values below 8.2% for sedentary, dynamic, and total activities, as well as postural transitions. However, with a sensitivity of 34.7% (20.3% to 55.3%), a PE of 49.0% (13.6% to 58.6%), and an APE of 51.6% (29.2% to 61.2%), the classification of standing activity resulted in unacceptable performance metrics.

Similarly, subgroup analysis of the data of orthopedic patients resulted in sensitivity, specificity, and accuracy values above 88.69%, with APE and PE values below 9.1% for the classification of sedentary, dynamic, and total activities, as well as postural transitions. The classification of standing showed a sensitivity of 71.8% (65.7% to 81.8%) and a PE of 9.1% (-18.5% to 23.7%). However, the APE values of the classification of standing and dynamic activities were too high (18.2% [12.8% to 30.4%] and 12.9% [4.9% to 22.1%], respectively) (Table 6.4, Figure 6.5). Detailed numeric results can be found in supplementary material Spreadsheet S2: S2_ValidationResults.xlsx.

Table 6.4 Median values (Q1 to Q3) of the performance metrics (% sensitivity, specificity, accuracy, PE, and APE) of the classification of activities by HFITAL within all patients of the validation group ($n=24$) and the subgroups of acutely hospitalized elderly patients ($n=12$) and orthopedic patients ($n=12$).

Activity	Population	Sensitivity (%)	Specificity (%)	Accuracy (%)	PE (%)	APE (%)
Sedentary	All Patients	98.7 (98.0 to 100.0)	98.2 (96.6 to 98.9)	98.5 (97.4 to 99.1)	-1.9 (-4.9 to -0.7)	1.9 (0.7 to 4.8)
	Acutely Hospitalized Elderly Patients	98.3 (96.5 to 99.9)	96.9 (93.4 to 98.2)	97.6 (95.6 to 98.1)	-2.1 (-5.4 to -1.7)	2.1 (1.7 to 5.4)
	Orthopedic Patients	99.3 (98.2 to 100.0)	98.9 (98.3 to 99.3)	98.9 (98.8 to 99.3)	-0.8 (-3.6 to 0.2)	0.8 (0.5 to 3.6)
	Total	89.2 (83.6 to 92.8)	94.6 (91.8 to 96.4)	92.8 (89.1 to 95.2)	0.2 (0.0 to 0.4)	8.6 (5.3 to 14.7)
Standing	All Patients	65.0 (34.1 to 76.9)	96.9 (92.7 to 98.5)	89.8 (85.8 to 93.7)	21.3 (-3.9 to 50.2)	29.2 (14.6 to 55.2)
	Acutely Hospitalized Elderly Patients	34.7 (20.3 to 55.3)	98.3 (96.9 to 99.7)	91.7 (86.4 to 95.4)	49.0 (13.6 to 58.6)	51.6 (29.2 to 61.2)
	Orthopedic Patients	71.8 (65.7 to 81.8)	93.1 (91.4 to 96.9)	89.6 (81.5 to 91.6)	9.1 (-18.5 to 23.7)	18.2 (12.8 to 30.4)
	Total	89.2 (83.6 to 92.8)	94.6 (91.8 to 96.4)	92.8 (89.1 to 95.2)	0.2 (0.0 to 0.4)	8.6 (5.3 to 14.7)
Dynamic	All Patients	94.3 (87.5 to 96.5)	89.2 (82.6 to 91.9)	90.5 (85.9 to 93.8)	-4.2 (-12.5 to 3.1)	8.6 (4.0 to 18.2)
	Acutely Hospitalized Elderly Patients	95.6 (94.6 to 97.9)	88.6 (63.9 to 91.9)	92.2 (87.1 to 95.1)	-5.1 (-11.6 to -1.6)	6.9 (2.2 to 15.4)
	Orthopedic Patients	91.9 (75.0 to 93.7)	89.2 (86.8 to 94.1)	90.1 (82.3 to 92.3)	-3.6 (-13.6 to 13.7)	12.9 (4.9 to 22.1)
	Total	89.2 (83.6 to 92.8)	94.6 (91.8 to 96.4)	92.8 (89.1 to 95.2)	0.2 (0.0 to 0.4)	8.6 (5.3 to 14.7)
Postural Transitions	All Patients	100.0 (100.0 to 100.0)	100.0 (100.0 to 100.0)	100.0 (100.0 to 100.0)	0.0 (0.0 to 0.0)	0.0 (0.0 to 0.0)
	Acutely Hospitalized Elderly Patients	100.0 (100.0 to 100.0)	100.0 (100.0 to 100.0)	100.0 (100.0 to 100.0)	0.0 (0.0 to 0.0)	0.0 (0.0 to 0.0)
	Orthopedic Patients	100.0 (82.3 to 100.0)	100.0 (100.0 to 100.0)	100.0 (82.3 to 100.0)	0.0 (0.0 to 3.1)	0.0 (0.0 to 14.4)
	Total	89.2 (83.6 to 92.8)	94.6 (91.8 to 96.4)	92.8 (89.1 to 95.2)	0.2 (0.0 to 0.4)	8.6 (5.3 to 14.7)

PE=percentage error. APE=absolute percentage error. MOXAL=adjustable classification algorithm validated in community-dwelling healthy elderly persons with an upper leg wear location, used as the starting point for the optimization process. MOXAL_{opt}=classification algorithm after optimization of three adjustable parameter settings of MOXAL to reduce the absolute percentage error for total activity. HFITAL=classification algorithm after additional modifications were introduced to MOXAL regarding the decision tree and the calculation of the amount of physical activity.

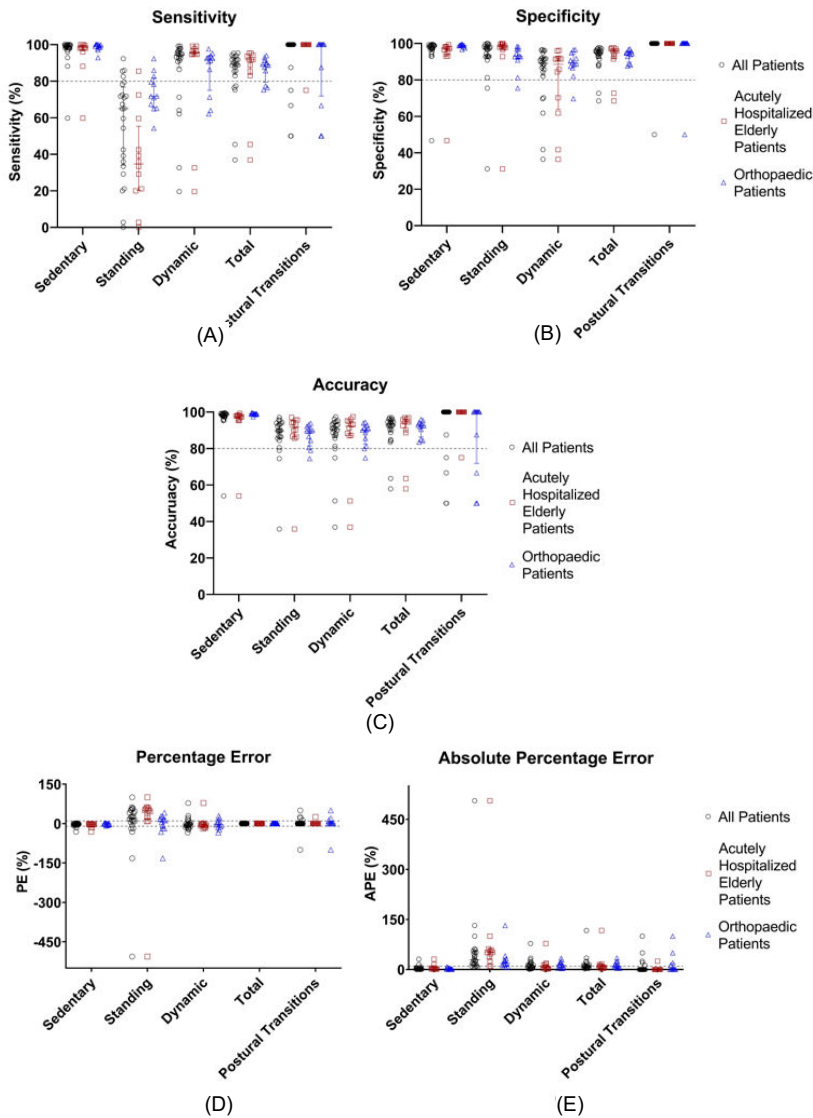

Figure 6.5 Performance metrics (% sensitivity (A), specificity (B), accuracy (C), percentage error (D), and absolute percentage error (E)) of the classification of activities by HFITAL within the validation group. All individual values are shown. Acceptable limits are represented by dashed lines. “All Patients” are represented in black, “Acutely Hospitalized Elderly Patients” in brown, and “Orthopaedic Patients” in blue. (MOXAL=adjustable classification algorithm validated in community-dwelling healthy elderly persons with an upper leg wear location, used as the starting point for the optimization process. MOXAL_{opt}=classification algorithm after optimization of three adjustable parameter settings of MOXAL to reduce the absolute percentage error for total activity. HFITAL=classification algorithm after additional modifications were introduced to MOXAL regarding the decision tree and the calculation of the amount of physical activity).

DISCUSSION

The primary aim of this study was to present and validate an optimized PA classification algorithm (HFITAL) which is able to discriminate between sedentary, standing, and dynamic activities, and able to detect postural transitions among hospitalized patients in a free-living setting. The results show that with an accelerometer worn on the upper leg, the best classification performance for HFITAL was achieved with the following parameter settings: a data segmentation window size (WS) of 4 s, an amount of physical activity threshold (PA Th), of 4.3 cps, and a sensor orientation threshold (SO Th) of 0.8 g. Validation of HFITAL showed that the classification of sedentary and dynamic activities, as well as the detection of postural transitions, produced sensitivity, specificity, and accuracy values above 89.0% and percentage error and absolute percentage error below 8.0%. Furthermore, the performance metrics of the classification of sedentary and dynamic activities, as well as the detection of postural transitions, fell within the acceptable limits for at least 75.0% of the patients, indicating the robustness of HFITAL. With a sensitivity of 65.0%, a PE of 21.3%, and an APE of 29.2%, only the classification of standing activities did not fall within acceptable limits.

The finding that it was difficult for HFITAL to correctly classify standing activity in hospitalized patients may have resulted from patients' slow or shuffling gait and the frequent use of walking aids. Standing as well as slow or shuffling gait are all characterized by small acceleration amplitudes. These comparable acceleration amplitudes lead to minimal differences between the amount of PA calculated for standing and dynamic activities, making it more difficult to select an appropriate PA Th to distinguish between these activities. The algorithm could thus have mistakenly classified standing activity as dynamic activity, resulting in a possible underestimation of the time classified as standing activity and an overestimation of the time classified as dynamic activity. The relatively low performance metrics for the classification of standing activity may also be explained by the relatively small amount of time spent in standing activity during the measurements, compared to the time spent in sedentary or dynamic activities. As sensitivity, specificity, and accuracy are influenced by the total measurement time per activity, a few misclassifications of standing activity could have resulted in a relatively larger effect on the performance metrics of standing compared to dynamic activity. Lastly, in order to assess the true performance of the algorithm, we refrained from excluding outliers from the analysis. All these factors may have contributed to the low median sensitivity, PE, and APE as well as the wide Q1 to Q3 for the classification of standing activity by HFITAL.

The subgroup analysis showed lower performance metrics for the classification of standing activity by HFITAL in acutely hospitalized elderly patients compared to

orthopedic patients. Slow gait and the use of walking aids are common in both populations⁸⁵⁻⁸⁷, which was confirmed by our video recordings. However, our recordings also showed a higher prevalence of shuffling gait in the acutely hospitalized elderly patients, including more time spent in double support, reduced step length, and reduced lifting of the feet during the swing phase of walking. These characteristics may have resulted in lower acceleration amplitudes for walking in this population, making it more difficult to correctly classify standing activity. Investigating the degree to which shuffling or slow gait contributed to the limited performance in the classification of standing activity requires further research, using a standardized protocol and including walking speed as an outcome measure.

For the optimization of the classification algorithm, we chose total activity APE as the performance metric used to select the best combination of adjustable parameters. This metric was selected to ensure that all three activity types would be correctly classified. Selecting a different performance metric could result in a different combination of parameter settings. This may improve the performance of the classification of standing activity but may possibly also negatively influence the performance of the classification of sedentary and dynamic activities. To the best of our knowledge, there is no consensus on which performance metrics should ideally be used. Further research is recommended to investigate which performance metrics are most suitable for the optimization of an adjustable PA classification algorithm.

The classification of sedentary, standing, and dynamic activities and postural transitions in hospitalized patients may be further improved by the use of a different type of classifier. Such a different type of classifier may also enable the classification of a broader range of activity types. Recently, pattern recognition and machine learning algorithms have received a great deal of attention^{88,89}. These types of classifiers could possibly overcome some of the limitations of the current algorithm. However, they also involve a higher computational load, making them less suitable for embedded software. Additionally, their interpretation is less intuitive than the current adjustable algorithm. Future research should explore the current state of algorithm development in order to achieve optimal PA classification in hospitalized patients. Another possibility to improve the classification of PA in hospitalized patients may be the use of multiple accelerometers. However, this is not practical in a clinical setting, requires more resources, and may adversely affect compliance^{42,60,90}.

As we included a range of different performance metrics, we have not only provided a complete overview of the performance of the algorithm, but also enabled comparisons with others studies. Nevertheless, comparing the results of the current study with those of other validation studies is challenging, due to differences

in the validation protocols, patient populations, accelerometer types, wear locations, and performance metrics used. Additionally, most studies have not transparently reported their classification algorithms, as these are often proprietary and not disclosed^{35,46,48}. Out of seven studies, only Lipperts et al. and Pedersen et al. have transparently described their classification algorithms^{12,35,46,48,55,61,62}.

Most previous studies investigating the validity of accelerometers in hospitalized patients were able to correctly classify sedentary (lying and/or sitting) activities^{12,46,48,55,61}, and all studies were able to correctly detect postural transitions^{46,55,61}. However, they all experienced difficulties in accurately classifying standing and/or walking activities, independent of their wear locations or study protocols^{12,35,46,48,55}. Brown et al. and Pedersen et al. were both unable to differentiate standing from walking in their respective samples of 39 and 6 acute medical patients aged 65 years or older. Brown et al. validated their algorithm using a free-living protocol with an accelerometer worn at the ankle, while Pedersen et al. used a standardized protocol with two accelerometers, one worn at the ankle and one on the upper leg. Neither used post-hoc video analysis as a reference, nor did they investigate the validity of the algorithm to detect postural transitions^{12,48}. Valkenet et al. investigated the validity of three accelerometers, each with a different algorithm and wear location (i.e., hip, upper thigh, and lumbar waist). Although the classification of walking showed good sensitivity values (90 to 95%) for all three wear locations, the classification of standing, sitting and lying showed lower sensitivity values, ranging between 13 and 79%, 57 and 94%, and 0 and 79%, respectively. However, the validation was performed with only two inpatients using a standardized protocol, and the validity of the algorithms to detect postural transitions was not investigated³⁵. Baldwin et al. investigated the validity of an accelerometer worn at the thigh in eight patients recovering from a critical illness. Although the validation was performed using a free-living protocol and the validity of the algorithm to detect postural transitions was investigated, direct observation by only one observer was used as a reference. The results showed an overestimation of the time spent standing and an underestimation of the time spent walking. With median (interquartile range) APE values of 21.9% (101.1%) for time spent standing and 18.7% (73.1%) for time spent walking, both values exceeded our acceptable limit of 10%⁴⁶. Although the median (Q1 to Q3) APE of 29.2% (14.6% to 55.2%) for standing activity found for HFITAL also exceeds this limit, walking was detected more accurately by HFITAL. Lastly, Lipperts et al. investigated the validity of an accelerometer worn at the lateral side of the unaffected leg, using a validation protocol approaching free-living conditions in 40 patients who underwent total joint arthroplasty 3–14 days prior to participation. Their results showed accuracy values above 92% for the classification of sitting, standing, level walking, stair climbing, and cycling activities and a mean error of duration of 2.9% for standing. As in our study, they found an underestimation of average standing

duration and an overestimation of average walking and sitting duration⁵⁵. However, as the patients included in our study had undergone total joint arthroplasty 1–2 days prior to participation, they can be assumed to have walked at a lower walking speed and with a more impaired gait pattern, which made it more challenging for HFITAL to correctly classify standing and dynamic activities. Taking into account that the current study was performed under free-living conditions in a population in which impaired and slow gait were common, the performance metrics of HFITAL are at least similar to, or possibly even better than, those reported by other validation studies.

A strength of our study is that the optimization and validation of the algorithm were performed in acutely hospitalized elderly patients and orthopedic patients following elective TKA or THA. These groups were deliberately chosen as they tend to walk very slowly, often with an impaired gait or walking aid, and therefore make accurate classification of standing and dynamic activities more challenging. The accelerometer is intended to be used in a wider variety of hospitalized patients, and we expect the performance metrics to be better when used in other patient populations. Second, our optimized algorithm and validation methodology were transparently described, enabling researchers and clinicians to compare the algorithm and results with other studies^{49,51,91}. Third, video recordings were used as a gold standard, with a good inter-observer reliability for the classification of all activities (ICC \geq 0.9). Fourth, the performance metrics of HFITAL were comparable for the optimization and validation groups, indicating a consistent performance of HFITAL when used to classify the PA behavior of patients outside the optimization group. Lastly, the validation of the optimized algorithm was performed under free-living conditions, providing a more accurate indication of the actual performance of the algorithm^{55,61}. As physical therapy sessions often comprise a significant part of patients' PA behavior during hospitalization, we chose to perform the validation during these sessions. This also ensured that sufficient time was spent performing standing and dynamic activities without consuming too much of the patients' time, thereby avoiding practical and ethical difficulties.

There are also some limitations to the current study that should be addressed. First, the physical therapists may have given patients instructions regarding their gait pattern or walking speed, thereby influencing natural conditions. Second, the duration of the validation protocol was influenced by the duration of the physical therapy session, resulting in shorter measurement periods than anticipated. However, a compromise had to be made between capturing sufficient time spent performing standing and dynamic activities and the duration of the free-living validation protocol. Third, walking speed was not assessed because the validation was performed under free-living conditions. This could, however, have enabled us to

investigate a possible relationship between walking speed and the ability of the algorithm to classify standing and dynamic activities within acceptable limits.

Our study has some important implications for clinical practice. As hospitalized patients need to increase their amount of PA and break up prolonged periods of sedentary activity, the classification of dynamic activity and the detection of postural transitions are considered the most important outcome measures for PA monitoring^{1,35,45}. The results show that although HFITAL is not able to classify standing activity accurately, it is able to validly classify sedentary and dynamic activities as well as postural transitions in hospitalized patients under free-living conditions. With performance metrics that are similar, or even better, than those of existing algorithms, HFITAL proves to be a good alternative. Moreover, HFITAL can be embedded in eHealth applications, such as Hospital Fit¹. As the algorithm involves a relatively low computational load, it is suitable to be embedded in an accelerometer without reducing its battery life. Embedding HFITAL in Hospital Fit will improve continuous PA monitoring with real-time feedback as a part of standard care. This will provide patients and healthcare professionals with more accurate feedback, enabling optimal support for patients' PA behavior and recovery.

CONCLUSIONS

The optimized PA classification algorithm (HFITAL) is able to validly classify sedentary and dynamic activities as well as to detect postural transitions under free-living conditions in hospitalized patients with an accelerometer worn on the upper leg. As hospitalized patients need to increase their amount of PA and interrupt prolonged periods of sedentary activity, HFITAL is a suitable algorithm to classify PA in these patients. In order to improve PA monitoring as a part of standard care and improve recovery in hospitalized patients, we propose to embed HFITAL in eHealth applications, such as Hospital Fit.

SUPPLEMENTARY INFORMATION

The following supplementary materials can be found online:

<https://www.mdpi.com/1424-8220/21/5/1652/s1>.

- Spreadsheet S1: S1_OptimizationResults.xlsx, contains the annotations and algorithm classifications for the optimization group.
- Spreadsheet S2: S2_ValidationResults.xlsx, contains the annotations and algorithm classifications for the validation group.

ACKNOWLEDGEMENTS

We would like to thank all physical therapists working at the Maastricht University Medical Center for their assistance in this study. We would also like to thank Joelle Thelen of Maastricht University for her assistance in video recording the included patients and H.Q. Chim and Jan Klerkx who provided language editing services.

APPENDICES

Appendix A

Equations A1.-A5 Equations for sensitivity, specificity, accuracy, percentage error (PE), and absolute percentage error (APE).

$$\text{Sensitivity} = \frac{TP}{TP + FN} \quad (\text{A1})$$

$$\text{Specificity} = \frac{TN}{TN + FP} \quad (\text{A2})$$

$$\text{Accuracy} = \frac{TP + TN}{TP + TN + FP + FN} \quad (\text{A3})$$

$$PE = \frac{\text{Tot Time Activity Class}_{\text{Video}} - \text{Tot Time Activity Class}_{\text{MOX}}}{\text{Tot Time Activity Class}_{\text{MOX}}} * 100 \quad (\text{A4})$$

$$APE = \frac{|\text{Tot Time Activity Class}_{\text{Video}} - \text{Tot Time Activity Class}_{\text{MOX}}|}{\text{Tot Time Activity Class}_{\text{MOX}}} * 100 \quad (\text{A5})$$

Appendix B

Table A6.1 Overview of the parameter settings of the activity classification algorithms evaluated during the optimization process.

	MOXAL	MOXAL _{Opt}	HFITAL
Sample Frequency (Hz)	25	25	25
Moving Average Window Size (samples)	3	3	9
Data Segmentation Window Size (samples)	50	20	100
Amount of Physical Activity Cut-Off Frequency (Hz)	1	0.15	0.15
Amount of Physical Activity Threshold	7	3.85	4.3 *
Sensor Orientation Low Pass Cut-Off Frequency	1.25	0.15	0.15
Sensor Orientation Threshold (g)	0.8	0.8	0.8

* Only the anterior-posterior axis was used to calculate the amount of physical activity. MOXAL=adjustable classification algorithm validated in community-dwelling healthy elderly persons with an upper leg wear location, used as the starting point for the optimization process. MOXAL_{Opt}=classification algorithm after optimization of three adjustable parameter settings of MOXAL to reduce the absolute percentage error for total activity. HFITAL=classification algorithm after additional modifications introduced to MOXAL regarding the decision tree and the calculation of the amount of physical activity.

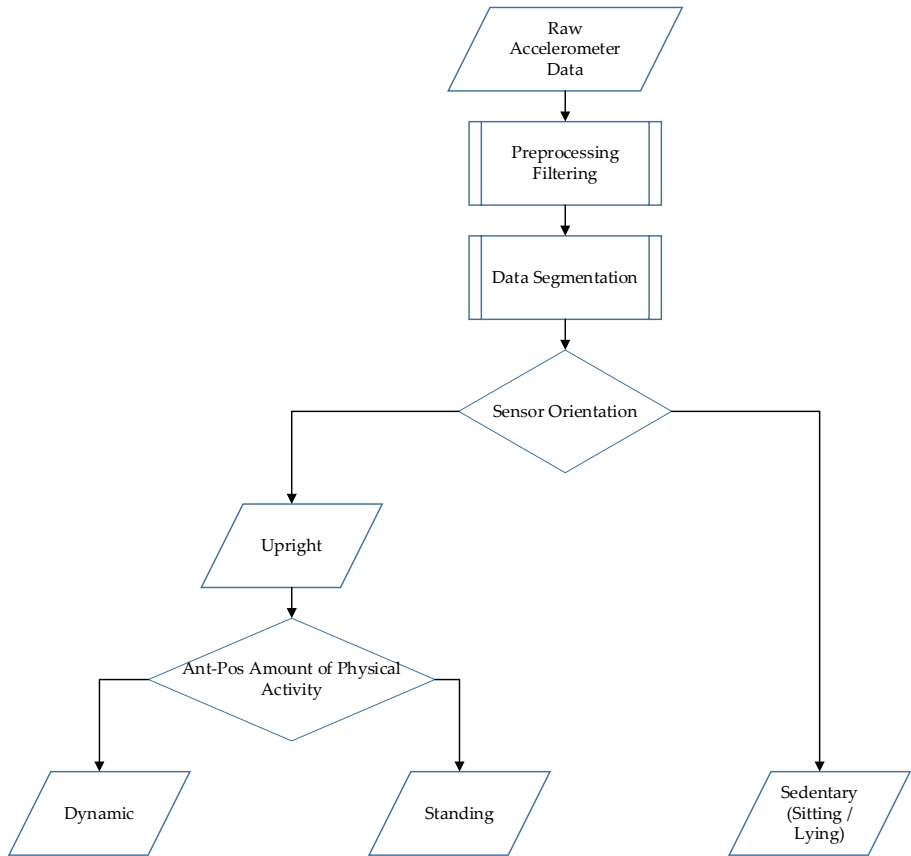

Figure A6.1 Schematic overview of the data processing of the physical activity classification algorithm (HFITAL) worn on the upper leg.

Appendix C

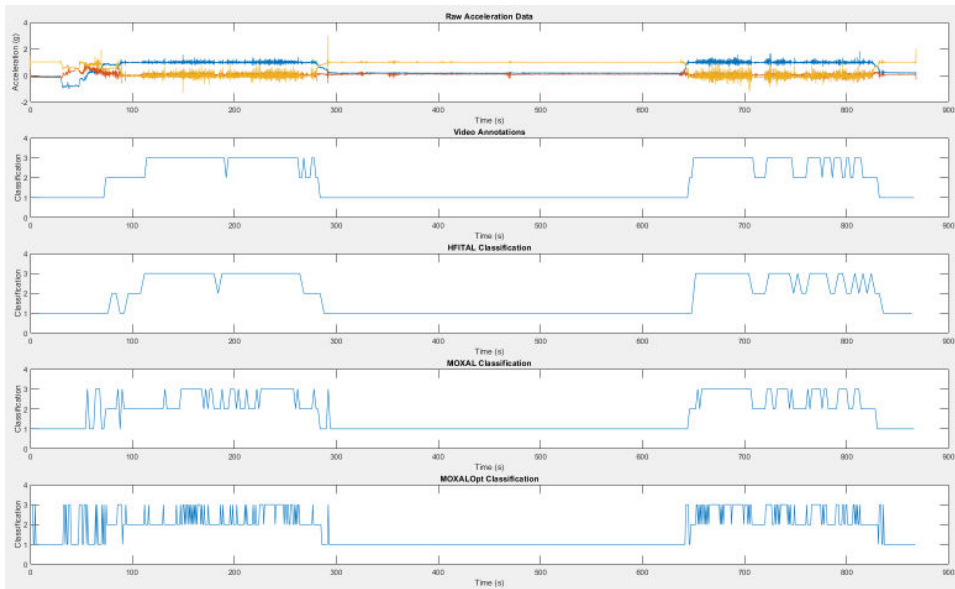

Figure A6.2 A graphical representation of the raw acceleration data, the video annotations and the classification of HFITAL, MOXAL, and MOXAL_{Opt}. The values 1, 2, 3, correspond to sedentary, standing, and dynamic activity, respectively. MOXAL_{Opt}=classification algorithm after optimization of three adjustable parameter settings of MOXAL to reduce the absolute percentage error for total activity. HFITAL=classification algorithm after additional modifications were introduced to MOXAL regarding the decision tree and the calculation of the amount of physical activity.

REFERENCES

1. Van Dijk-Huisman HC, Weemaes ATR, Boymans T, Lenssen AF, de Bie RA. Smartphone App with an Accelerometer Enhances Patients' Physical Activity Following Elective Orthopedic Surgery: A Pilot Study. *Sensors*. 2020;20:4317.
2. Fazio S, Stocking J, Kuhn B, Doroy A, Blackmon E, Young HM, Adams JY. How much do hospitalized adults move? A systematic review and meta-analysis. *Appl Nurs Res*. 2020;51:151189.
3. Baldwin C, van Kessel G, Phillips A, Johnston K. Accelerometry Shows Inpatients With Acute Medical or Surgical Conditions Spend Little Time Upright and Are Highly Sedentary: Systematic Review. *Phys Ther*. 2017;97:1044-65.
4. Fini NA, Holland AE, Keating J, Simek J, Bernhardt J. How Physically Active Are People Following Stroke? Systematic Review and Quantitative Synthesis. *Phys Ther*. 2017;97:707-17.
5. Ekegren CL, Beck B, Climie RE, Owen N, Dunstan DW, Gabbe BJ. Physical Activity and Sedentary Behavior Subsequent to Serious Orthopedic Injury: A Systematic Review. *Arch Phys Med Rehabil*. 2018;99:164-77.e166.
6. Baldwin CE, Parry SM, Norton L, Williams J, Lewis LK. A scoping review of interventions using accelerometers to measure physical activity or sedentary behaviour during hospitalization. *Clin Rehabil*. 2020;34:1157-72.
7. Evensen SSO, Lydersen S, Taraldsen K. Physical activity among hospitalized older adults—An observational study. *BMC Geriatr*. 2017;17:110.
8. Browning L, Denehy L, Scholes RL. The quantity of early upright mobilisation performed following upper abdominal surgery is low: An observational study. *Aust J Physiother*. 2007;53:47-52.
9. Davenport SJ, Arnold M, Hua C, Schenck A, Batten S, Taylor NF. Physical Activity Levels During Acute Inpatient Admission After Hip Fracture are Very Low. *Physiother Res Int*. 2015;20:174-181.
10. Taraldsen K, Sletvold O, Thingstad P, Saltvedt I, Granat MH, Lydersen S, Helbostad JL. Physical behavior and function early after hip fracture surgery in patients receiving comprehensive geriatric care or orthopedic care—a randomized controlled trial. *J Gerontol A Biol Sci Med Sci*. 2014;69: 338-45.
11. Fisher SR, Goodwin JS, Protas EJ, Kuo YF, Graham JE, Ottenbacher KJ, Ostir GV. Ambulatory activity of older adults hospitalized with acute medical illness. *J Am Geriatr Soc*. 2011;59:91-95.
12. Pedersen MM, Bodilsen AC, Petersen J, Beyer N, Andersen O, Lawson-Smith L, Kehlet H, Bandholm T. Twenty-four-hour mobility during acute hospitalization in older medical patients. *J Gerontol Ser A Biol Sci Med Sci*. 2013;68:331-7.
13. Villumsen M, Jorgensen MG, Andreasen J, Rathleff MS, Mølgaard CM. Very Low Levels of Physical Activity in Older Patients During Hospitalization at an Acute Geriatric Ward: A Prospective Cohort Study. *J Aging Phys Act*. 2015;23:542-9.
14. Borges RC, Carvalho CR. Physical activity in daily life in Brazilian COPD patients during and after exacerbation. *COPD*. 2012;9:596-602.
15. Borges RC, Carvalho CR, Colombo AS, da Silva Borges MP, Soriano FG. Physical activity, muscle strength, and exercise capacity 3 months after severe sepsis and septic shock. *Intensive Care Med*. 2015;41:1433-44.
16. Brown CJ, Redden DT, Flood KL, Allman RM. The underrecognized epidemic of low mobility during hospitalization of older adults. *J Am Geriatr Soc*. 2009;57:1660-5.
17. Cattanach N, Sheedy R, Gill S, Hughes A. Physical activity levels and patients' expectations of physical activity during acute general medical admission. *Intern Med J*. 2014;44:501-4.
18. Howie-Esquivel J, Zoharios E. Using Novel Technology to Determine Mobility among Hospitalized Heart Failure Patients: A Pilot Study. *Cardiol Res*. 2013;4:15-25.
19. Kuys SS, Dolecka UE, Guard A. Activity level of hospital medical inpatients: An observational study. *Arch Gerontol Geriatr*. 2012;55:417-21.
20. Mudge AM, McRae P, McHugh K, Griffin L, Hitchen A, Walker J, Cruickshank M, Morris NR, Kuys S. Poor mobility in hospitalized adults of all ages. *J Hosp Med*. 2016;11:289-91.
21. Askim T, Bernhardt J, Churilov L, Fredriksen KR, Indredavik B. Changes in physical activity and related functional and disability levels in the first six months after stroke: A longitudinal follow-up study. *J Rehabil Med*. 2013;45:423-8.

22. Prakash V, Shah MA, Hariohm K. Family's presence associated with increased physical activity in patients with acute stroke: An observational study. *Braz J Phys Ther.* 2016;20:306–11.
23. King A, McCluskey A, Schurr K. The time use and activity levels of inpatients in a co-located acute and rehabilitation stroke unit: An observational study. *Top. Stroke Rehabil.* 2011;18 (Suppl. 1):654–65.
24. Kramer SF, Churilov L, Kroeders R, Pang MY, Bernhardt J. Changes in activity levels in the first month after stroke. *J Phys Sci.* 2013;25:599–604.
25. Kunkel D, Fitton C, Burnett M, Ashburn A. Physical inactivity post-stroke: A 3-year longitudinal study. *Disabil Rehabil.* 2015;37:304–10.
26. Hokstad A, Indredavik B, Bernhardt J, Ihle-Hansen H, Salvesen Ø, Seljeseth YM, Schüler S, Engstad T, Askim T. Hospital differences in motor activity early after stroke: A comparison of 11 Norwegian stroke units. *J Stroke Cereb Dis.* 2015;24:1333–40.
27. Berney SC, Rose JW, Bernhardt J, Denehy L. Prospective observation of physical activity in critically ill patients who were intubated for more than 48 hours. *J Crit Care.* 2015;30:658–63.
28. Connolly BA, Mortimore JL, Douiri A, Rose JW, Hart N, Berney SC. Low Levels of Physical Activity During Critical Illness and Weaning: The Evidence-Reality Gap. *J Intensive Care Med.* 2019;34:818–27.
29. Buurman BM, Hoogerduijn JG, de Haan RJ, Abu-Hanna A, Lagaay AM, Verhaar HJ, Schuurmans MJ, Levi M, de Rooij SE. Geriatric conditions in acutely hospitalized older patients: Prevalence and one-year survival and functional decline. *PLoS One.* 2011;6:e26951.
30. Dirks ML, Wall BT, van de Valk B, Holloway TM, Holloway GP, Chabowski A, Goossens GH, van Loon LJ. One Week of Bed Rest Leads to Substantial Muscle Atrophy and Induces Whole-Body Insulin Resistance in the Absence of Skeletal Muscle Lipid Accumulation. *Diabetes.* 2016;65:2862–75.
31. Abeles A, Kwasnicki RM, Pettengell C, Murphy J, Darzi A. The relationship between physical activity and post-operative length of hospital stay: A systematic review. *Int J Surg.* 2017;44:295–302.
32. Ostir GV, Berges IM, Kuo YF, Goodwin JS, Fisher SR, Guralnik JM. Mobility activity and its value as a prognostic indicator of survival in hospitalized older adults. *J Am Geriatr Soc.* 2013;61:551–7.
33. Duvivier BM, Schaper NC, Bremers MA, van Crombrugge G, Menheere PP, Kars M, Savelberg HH. Minimal intensity physical activity (standing and walking) of longer duration improves insulin action and plasma lipids more than shorter periods of moderate to vigorous exercise (cycling) in sedentary subjects when energy expenditure is comparable. *PLoS One.* 2013;8:e55542.
34. Weijs PJ, Looijaard WG, Dekker IM, Stapel SN, Girbes AR, Oudemans-van Straaten HM, Beishuizen A. Low skeletal muscle area is a risk factor for mortality in mechanically ventilated critically ill patients. *Crit Care.* 2014;18:R12.
35. Valkenet K, Veenhof C. Validity of three accelerometers to investigate lying, sitting, standing and walking. *PLoS One.* 2019;14:e0217545.
36. So C, Pierluissi E. Attitudes and expectations regarding exercise in the hospital of hospitalized older adults: A qualitative study. *J Am Geriatr Soc.* 2012;60:713–8.
37. Hoyer EH, Friedman M, Lavezza A, Wagner-Kosmakos K, Lewis-Cherry R, Skolnik JL, Byers SP, Atanelov L, Colantuoni E, Brotman DJ, et al. Promoting mobility and reducing length of stay in hospitalized general medicine patients: A quality-improvement project. *J Hosp Med.* 2016;11:341–7.
38. Lorgunpai SJ, Finke B, Burrows I, Brown CJ, Rubin FH, Wierman HR, Heisey SJ, Gartaganis S, Ling SM, Press M, et al. Mobility Action Group: Using Quality Improvement Methods to Create a Culture of Hospital Mobility. *J Am Geriatr Soc.* 2020;68:2373–81.
39. Agmon M, Zisberg A, Gil E, Rand D, Gur-Yaish N, Azriel M. Association between 900 Steps a Day and Functional Decline in Older Hospitalized Patients. *JAMA Intern Med.* 2017;177:272–4.
40. Berendsen BA, Hendriks MR, Meijer K, Plasqui G, Schaper NC, Savelberg HH. Which activity monitor to use? Validity, reproducibility and user friendliness of three activity monitors. *BMC Public Health.* 2014;14:749.
41. Lim SER, Ibrahim K, Sayer AA, Roberts HC. Assessment of Physical Activity of Hospitalised Older Adults: A Systematic Review. *J Nutr Health Aging.* 2018;22:377–86.
42. Cheung VH, Gray L, Karunanithi M. Review of accelerometry for determining daily activity among elderly patients. *Arch Phys Med Rehabil.* 2011;92:998–1014.
43. Lindemann U, Zijlstra W, Aminian K, Chastin S, de Bruin E, Helbostad J, Busmann J. Recommendations for standardizing validation procedures assessing physical activity of older persons by monitoring body postures and movements. *Sensors.* 2014;14:1267–77.

44. Van Delft L, Bor P, Valkenet K, Slooter A, Veenhof C. The Effectiveness of Hospital in Motion, a Multidimensional Implementation Project to Improve Patients' Movement Behavior during Hospitalization. *Phys Ther.* 2020;100:2090-98.
45. Kramer SF, Cumming T, Churilov L, Bernhardt J. Measuring activity levels at an acute stroke ward: Comparing observations to a device. *Biomed Res Int.* 2013;2013:460482.
46. Baldwin CE, Johnston KN, Rowlands AV, Williams MT. Physical activity of ICU survivors during acute admission: Agreement of the activPAL with observation. *Physiother Can.* 2018;70:57-63.
47. Patterson F, Blair V, Currie A, Reid W. An investigation into activity levels of older people on a rehabilitation ward: An observational study. *Physiotherapy.* 2005;91:28-34.
48. Brown CJ, Roth DL, Allman RM. Validation of use of wireless monitors to measure levels of mobility during hospitalization. *J Rehabil Res Dev.* 2008;45:551-8.
49. Bijmens W, Aarts J, Stevens A, Ummels D, Meijer K. Optimization and validation of an adjustable activity classification algorithm for assessment of physical behavior in elderly. *Sensors.* 2019;19:5344.
50. Ainsworth B, Cahalin L, Buman M, Ross R. The current state of physical activity assessment tools. *Prog Cardiovasc Dis.* 2015;57:387-95.
51. Welk GJ, Bai Y, Lee JM, Godino J, Saint-Maurice PF, Carr L. Standardizing Analytic Methods and Reporting in Activity Monitor Validation Studies. *Med Sci Sports Exerc.* 2019;51:1767-80.
52. Banos O, Galvez JM, Damas M, Pomares H, Rojas I. Window size impact in human activity recognition. *Sensors.* 2014;14:6474-99.
53. Bersch SD, Azzi D, Khusainov R, Achumba IE, Ries J. Sensor data acquisition and processing parameters for human activity classification. *Sensors.* 2014;14:4239-70.
54. Bouten CV, Koekkoek KT, Verduin M, Kodde R, Janssen JD. A triaxial accelerometer and portable data processing unit for the assessment of daily physical activity. *IEEE Trans Biomed Eng.* 1997;44: 136-47.
55. Lipperts M, van Laarhoven S, Senden R, Heyligers I, Grimm B. Clinical validation of a body-fixed 3D accelerometer and algorithm for activity monitoring in orthopaedic patients. *J Orthop Transl.* 2017;11: 19-29.
56. Mathie MJ, Coster AC, Lovell NH, Celler BG. Detection of daily physical activities using a triaxial accelerometer. *Med Biol Eng Comput.* 2003;41:296-301.
57. Preece SJ, Goulermas JY, Kenney LP, Howard D, Meijer K, Crompton R. Activity identification using body-mounted sensors--a review of classification techniques. *Physiol Meas.* 2009;30:R1-33.
58. Chen KY, Janz KF, Zhu W, Brychta RJ. Redefining the roles of sensors in objective physical activity monitoring. *Med Sci Sports Exerc.* 2012;44:s13-s23.
59. Evenson KR, Goto MM, Furberg RD. Systematic review of the validity and reliability of consumer-wearable activity trackers. *Int J Behav Nutr Phys Act.* 2015;12:159.
60. Anderson JL, Green AJ, Yoward LS, Hall HK. Validity and reliability of accelerometry in identification of lying, sitting, standing or purposeful activity in adult hospital inpatients recovering from acute or critical illness: A systematic review. *Clin Rehabil.* 2018;32:233-42.
61. Taraldsen K, Askim T, Sletvold O, Einarsen EK, Bjåstad KG, Indredavik B, Helbostad JL. Evaluation of a body-worn sensor system to measure physical activity in older people with impaired function. *Phys Ther.* 2011;91:277-85.
62. Anderson JL, Yoward LS, Green AJ. A study investigating the validity of an accelerometer in quantification of step count in adult hospital inpatients recovering from critical illness. *Clin Rehabil.* 2019;33:936-42.
63. Valkenet K, Bor P, van Delft L, Veenhof C. Measuring physical activity levels in hospitalized patients: A comparison between behavioural mapping and data from an accelerometer. *Clin Rehabil.* 2019;33: 1233-40.
64. De Morton NA, Berlowitz DJ, Keating JL. A systematic review of mobility instruments and their measurement properties for older acute medical patients. *Health Qual Life Outcomes.* 2008;6:44.
65. Bourk AK, Ihlen EAF, Helbostad JL. Validation of the activPAL3 in free-living and laboratory scenarios for the measurements of physical activity, stepping and transitions in older adults. *Hum Kinet J.* 2019; 2:59-65.
66. Beevl FHA, Miranda J, Pedersen CF, Wagner S. An evaluation of commercial pedometers for monitoring slow walking speed populations. *Telemed J E Health.* 2016;22:441-9.
67. Ferjuson T, Rowlands AV, Olds T, Maher C. The validity of consumer-level, activity monitors in healthy adults worn in free living conditions: A cross sectional study. *Int J Behav Nutr Phys Act.* 2015;27:42.

68. Burton E, Hill KD, Lautenschlager NT, Thogersen-Ntoumani C, Lewin G, Boyle E, Howie E. Reliability and validity of two fitness tracker devices in the lab and home environment for older community dwelling people. *BMC Geriatr.* 2018;18:103.
69. Floegel TA, Florez-Pregonero A, Hekler EB, Buman MP. Validation of consumer based hip and wrist activity monitors in older adults with varied ambulatory abilities. *J Gerontol A Biol Sci Med Sci.* 2017; 72:229-36.
70. Koenders N, Seeger JPH, van der Giessen T, van den Hurk TJ, Smits IGM, Tankink AM, Nijhuis-van der Sanden MWG, Hoogeboom TJ. Validation of a wireless patch sensor to monitor mobility tested in both an experimental and a hospital setup: A cross-sectional study. *PLoS One* 2018;13:e0206304.
71. Lugade V, Fortune E, Morrow M, Kaufman K. Validity of using tri-axial accelerometers to measure human movement—Part I: Posture and movement detection. *Med Eng Phys.* 2014;36:169-76.
72. Fortune E, Lugade V, Morrow M, Kaufman K. Validity of using tri-axial accelerometers to measure human movement—Part II: Step counts at a wide range of gait velocities. *Med Eng Phys.* 2014;36: 659-69.
73. De Vries SI, Garre FG, Engbers LH, Hildebrandt VH, van Buuren S. Evaluation of neural networks to identify types of activity using accelerometers. *Med Sci Sports Exerc.* 2011;43:101-7.
74. Annegarn J, Spruit MA, Uszko-Lencer NH, Vanbelle S, Savelberg HH, Schols AM, Wouters EF, Meijer K. Objective physical activity assessment in patients with chronic organ failure: A validation study of a new single-unit activity monitor. *Arch Phys Med Rehabil.* 2011;92:1852-7.
75. Van Roekel EH, Winkler EA, Bours MJ, Lynch BM, Willems PJ, Meijer K, Kant I, Beets GL, Sanduleanu S, Healy GN, et al. Associations of sedentary time and patterns of sedentary time accumulation with health-related quality of life in colorectal cancer survivors. *Prev Med Rep.* 2016;4:262-9.
76. Stevens ML, Gupta N, Inan Eroglu E, Crowley PJ, Eroglu B, Bauman A, Granat M, Straker L, Palm P, Stenholm S, et al. Thigh-worn accelerometry for measuring movement and posture across the 24-hour cycle: A scoping review and expert statement. *BMJ Open Sport Exerc Med.* 2020;6:e000874.
77. Hamer M, Stamatakis E, Chastin S, Pearson N, Brown M, Gilbert E, Sullivan A. Feasibility of Measuring Sedentary Time Using Data From a Thigh-Worn Accelerometer. *Am J Epidemiol.* 2020;189:963-71.
78. Montoye AHK, Pivarnik JM, Mudd LM, Biswas S, Pfeiffer KA. Validation and Comparison of Accelerometers Worn on the Hip, Thigh, and Wrists for Measuring Physical Activity and Sedentary Behavior. *AIMS Public Health.* 2016;3:298-312.
79. Friard O, Gamba M. BORIS: A free, versatile open-source event-logging software for video/audio coding and live observations. *Methods Ecol Evol.* 2016;7:1325-30.
80. De Vet HCW, Terwee CB, Mokkink LB, Knol DL. *Measurement in Medicine: A Practical Guide (Practical Guides to Biostatistics and Epidemiology)*; Cambridge University Press: Cambridge, UK, 2011, doi:10.1017/CBO9780511996214.
81. Ruuska S, Hämäläinen W, Kajava S, Mughal M, Matilainen P, Mononen J. Evaluation of the confusion matrix method in the validation of an automated system for measuring feeding behaviour of cattle. *Behav Process.* 2018;148:56-62.
82. Sasaki JE, Hickey A, Staudenmayer JW, John D, Kent JA, Freedson PS. Performance of Activity Classification Algorithms in Free-Living Older Adults. *Med Sci Sports Exerc.* 2016;48:941-50.
83. Fanchamps MHJ, Horemans HLD, Ribbers GM, Stam HJ, Bussmann JBJ. The accuracy of the detection of body postures and movements using a physical activity monitor in people after stroke. *Sensors.* 2018;18:2167.
84. Van den Berg-Emons RJ, Bussmann JB, Stam HJ. Accelerometry-based activity spectrum in persons with chronic physical conditions. *Arch Phys Med Rehabil.* 2010;91:1856-61.
85. Osoba MY, Rao AK, Agrawal SK, Lalwani AK. Balance and gait in the elderly: A contemporary review. *Laryngoscope Investig Otolaryngol.* 2019;4:143-53.
86. Bączkiewicz D, Skiba G, Czerner M, Majorczyk E. Gait and functional status analysis before and after total knee arthroplasty. *Knee.* 2018;25:888-96.
87. Colgan G, Walsh M, Bennett D, Rice J, O'Brien T. Gait analysis and hip extensor function early post total hip replacement. *J Orthop.* 2016;13:171-6.
88. Farrahi V, Niemelä M, Kangas M, Korpelainen R, Jämsä T. Calibration and validation of accelerometer-based activity monitors: A systematic review of machine-learning approaches. *Gait Posture.* 2019;68:285-99.

89. Liu L, Wang S, Hu B, Qiong Q, Wen J, Rosenblum DS. Learning structures of interval-based Bayesian networks in probabilistic generative model for human complex activity recognition. *Pattern Recognit.* 2018;81:545–61.
90. Atallah L, Lo B, King R, Guang-Zhong Y. Sensor positioning for activity recognition using wearable accelerometers. *IEEE Trans Biomed Circuits Syst.* 2011;5:320–9.
91. Bunn JA, Navalta JW, Fountaine CJ, Reece JD. Current State of Commercial Wearable Technology in Physical Activity Monitoring 2015–2017. *Int J Exerc Sci.* 2018;11:503–15.



CHAPTER SEVEN

GENERAL DISCUSSION

GENERAL DISCUSSION

The main aim of this thesis is to contribute to improving patients' physical activity behaviour during hospitalisation. In this general discussion, the main findings and methodological considerations are discussed. Furthermore, implications for clinical practice and recommendations for future research are presented.

Main findings

The importance of promoting physical activity and preventing the negative effects associated with sedentary behaviour in hospitalised patients is gaining increasing attention worldwide¹. Interventions to promote physical activity are needed, but are more likely to be effective if they are designed to target underlying barriers and enablers that influence this behaviour^{2,3}. Therefore, understanding which barriers and enablers influence hospitalised patients' physical activity behaviour is a first step towards identifying potentially modifiable factors and developing, evaluating and implementing targeted interventions^{2,4,5}. To increase our understanding of factors that influence patients' physical activity behaviour during hospitalisation, a scoping review was conducted in chapter 2. We identified all published patient- and healthcare professional-reported barriers and enablers to physical activity during hospital stay from a broad perspective across many settings and populations. Subsequently, the Theoretical Domains Framework (TDF) was used to categorise these factors. This resulted in an overview of 110 different barriers and 78 different enablers reported by patients, and 153 different barriers and 150 different enablers reported by healthcare professionals. This large number of factors, distributed across many TDF domains, demonstrates the complexity of changing patients' physical activity behaviour during hospital stay. Moreover, the prominent role of the social and physical hospital environment on patients' physical activity behaviour are also highlighted. The overview of barriers and enablers provides a foundation to guide clinicians and researchers in future development, evaluation and implementation of interventions aimed at promoting physical activity during hospitalisation.

In chapters 3, 4 and 6 we focus specifically on older adults admitted to hospital with an acute medical illness, for they are at increased risk of negative outcomes associated with inactivity. With increasing age, their adaptive capacity gradually decreases⁶. The high prevalence of multi-morbidity and age-related impairments make them vulnerable, especially during an acute hospital admission⁷. A qualitative study was performed in chapter 3 to explore barriers and enablers to physical activity during a hospital stay in older adults admitted to the Maastricht University Medical Centre (MUMC+) with an acute medical illness. In this setting-specific analysis, barriers and enablers as perceived by older adults and their nurses,

physicians, and physiotherapists were identified and categorised using the TDF. This resulted in 70 different barriers and 97 different enablers reported by patients, as well as 115 different barriers and 197 different enablers reported by healthcare professionals. Although we expected to find less barriers and enablers than in chapter 2, the large number of barriers and enablers indicates that the complexity of changing patients' physical activity behaviour during hospital stay remains, even when investigated in a single population and setting. This setting-specific overview provides a first step towards identifying potentially modifiable factors and developing, evaluating and implementing targeted, personalised interventions aimed at increasing older adults' physical activity behaviour during hospitalisation. It can assist clinicians and researchers in selecting modifiable factors that can be targeted in future interventions.

Although chapters 2 and 3 showed many corresponding barriers and enablers, a number of new factors were identified in chapter 3. One factor that we would like to highlight is the perceived positive influence of technology (e.g., wearables, digital patient portals, tablets, interactive biking systems, or virtual reality) on older adults' physical activity behaviour. Although most of these technological innovations are not integrated in usual care yet, older adults and their healthcare professionals believe that they may improve patients' physical activity behaviour. As the use of wearables and other technological innovations in healthcare has expanded over the last decade, we expect that this enabler will also be relevant in other patient populations and settings.

Furthermore, healthcare professionals described the importance of performing an assessment of patients' functional capabilities shortly after hospital admission, and of optimising roles and responsibilities regarding physical activity promotion within a multidisciplinary team. Moreover, both patients and healthcare professionals recommended creating separate areas for sleeping and daytime activities in order to promote spending time out of bed. Additionally, they suggested that organised activities should be offered throughout the whole day, including weekends. Although these newly identified factors could be specific to older adults admitted to the MUMC+ with a medical illness, we speculate that they also apply to other populations and settings and may have been underexplored in previous studies.

Both studies also showed many corresponding barriers and enablers and highlight the complexity of changing patients' physical activity behaviour during hospitalisation. They demonstrated that barriers and enablers appear at an individual as well as at a system level. At an individual level, patient's physical activity behaviour may be influenced by the level of knowledge and skills, attitudes, beliefs, emotions, and intentions of patients, healthcare professionals and visitors. Social interaction between patients, healthcare professionals and visitors can also

affect patients' physical activity behaviour. At a system level, organisational factors, care processes, the physical hospital environment and the availability of resources may also influence the behaviour of patients, healthcare professionals and visitors.

The complexity of changing movement behaviour during hospitalisation has also been addressed by others^{1,8}. Chastin et al. described that sedentary behaviour during hospitalisation is affected by culture, environment, people and operational processes, and called it a "wicked problem". Wicked problems are simple on the surface but extremely complex in reality, and often resistant to resolution. They are characterised by the influence of multiple interacting factors that are deeply entangled. This makes them seemingly impossible to solve, as there is no definitive panacea for a wicked problem¹. The solution to changing patients' physical activity behaviour during hospitalisation seems simple, all patients have to do is get out of their beds and get moving. However, in daily clinical practise it turns out to be a complex issue that is influenced by many different factors interacting at individual and system levels.

In chapter 4 we investigated whether we are able to identify older adults at high risk of spending little time standing and walking. If patients at high risk could be identified early after admission, they could be given targeted interventions aimed at increasing their physical activity behaviour. Predicting which patients are at high risk can therewith contribute to improved patient outcomes. Two prediction models were developed and internally validated. Both models show good discriminative ability and prediction capabilities for older adults at high risk of spending little time standing and walking during hospitalisation. The developed prediction models can be used in clinical practice by performing a simple screening early after admission, consisting of the Short Physical Performance Battery (SPPB) and Activity Measure for Post-Acute Care Inpatient Basic Mobility short form (AM-PAC), combined with information on patients' age, sex and walking aid use.

One of the challenges in this study was to determine cut-off values regarding low and high risk of spending little time active. To determine if patients are at high risk of spending little time active, it is important to know how much physical activity is needed to prevent the negative effects associated with inactivity. Unfortunately, decision aids, protocols or clinical guidelines on physical activity and sedentary behaviour during hospitalisation do not exist yet⁹⁻¹⁴. Given that hospitalised patients spend between 87% and 100% of their day lying in bed or sitting in a chair^{11,15-17}, most patients are not able to meet the recommendations set out by the World Health Organisation (WHO)¹⁸. Baldwin et al. provided the first international consensus for recommendations on physical activity and sedentary behaviour for older adults while hospitalised with an acute medical illness. They recommend that older adults should be as physically active as their abilities and conditions allow, adding

movement into everyday activities and incrementally if required. Furthermore, long periods of uninterrupted sedentary behaviour during waking hours should be minimised. Additionally, muscle strengthening and balance exercises were also regarded as important¹². However, the optimal-dose response relationship to prevent negative outcomes of inactivity remains unknown, and clear criterion-referenced cut-off values regarding the classification of low and high physical activity levels are still lacking⁹⁻¹⁴.

Since we could not use criterion-referenced cut-off values in our prediction models, we used a data-driven approach based on norm-referenced cut-off values. Because literature has shown large variations in time spent active in older adults admitted for acute medical illness^{9,19-25}, we aimed to be able to identify patients that were the least active. We initially aimed to develop one prediction model in which 50.0% of the patients was categorised at high risk of spending little time standing and walking. This cut-off value resulted in a favourable sample size. However, it also meant that half of the patients would be considered eligible for interventions, which may require substantial financial resources. Therefore, we decided to develop a second model, to explore a cut-off value of 33.3% as well. This second model enables the identification of the one-third of all patients that are expected to be the least active. Although criterion-referenced cut-off values are lacking, the prediction models contribute to providing value-based healthcare through being able to identify patients that are likely to benefit most from interventions aimed at improving their physical activity behaviour.

In chapter 5 we investigated the potential of Hospital Fit, an intervention aimed at improving physical activity behaviour and speed of functional recovery of hospitalised patients following elective orthopaedic surgery. Hospital Fit consist of a smartphone application connected to an accelerometer and enables objective activity monitoring. It provides patients feedback on their physical activity behaviour and extent of functional recovery, through enabling personalised goalsetting, and through providing a personalised exercise program. The results show an increase in time spent standing and walking, as well as higher odds of functional recovery on postoperative day one in patients using Hospital Fit. The study also led to suggestions for improvement of Hospital Fit, such as improving the accelerometer algorithm. In chapter 6 we built upon this by optimising and validating an accelerometer algorithm that can discriminate between sedentary, standing, and dynamic activities, and that can detect postural transitions among hospitalised patients under free-living conditions. Validation showed that all activities were classified within acceptable limits (>80% sensitivity, specificity and accuracy, $\pm 10\%$ error), except for the classification of standing activity. To improve physical activity monitoring in hospitalised patients, we propose to embed the algorithm in eHealth applications, such as Hospital Fit.

For the last two decades, accelerometers were predominantly used to monitor the physical activity behaviour of hospitalised patients for research purposes. The lack of accelerometers to provide real time feedback is one of the main factors that limits their use in clinical care. Many commercially available activity trackers or smartphones provide real time feedback on physical activity behaviour. However, most of them are not validated to measure the physical activity behaviour of patients using walking aids, or with slow or impaired gait.

Chapters 5 and 6 demonstrate that we have a tool that enables accurate physical activity monitoring in hospitalised patients and that provides real time feedback to patients and their physiotherapists. Although this enables objective physical activity monitoring in daily clinical care, clinical guidelines that support clinicians in determining if a patient has been sufficiently active are still lacking⁹⁻¹⁴. Additionally, the amount of physical activity needed to prevent the negative effects of inactivity may be influenced by other factors such as preadmission status, illness severity or daily caloric intake, necessitating more personalised recommendations. As a result, recommendations given to patients regarding their physical activity behaviour remain influenced by subjectivity.

Methodological considerations

Theoretical domains framework

As the Medical Research Council guidance on the development of complex interventions advocates the use of theory to identify barriers and enablers to behaviour change²⁶, we have chosen to use the TDF as a theoretical framework in chapters 2 and 3. The TDF is an overarching theoretical framework in which constructs of 33 theories of behaviour and behaviour change are integrated and simplified into 14 domains²⁷. Due to the large number of factors identified in both studies, the use of a framework was necessary to provide structure to the data and to unravel the complex mechanism of hospitalised patients' physical activity behaviour.

However, the use of the TDF also induced some challenges. Although an overview of theoretical definitions and component constructs was used to guide the coding process, we experienced difficulties in differentiating between some of the TDF domains, which was also reported by other studies^{28,29}. This may have created a number of barriers and enablers that seem very similar but were categorised into different domains. As some of these factors could be targeted with the same interventions, we believe that the number of barriers and enablers could have been reduced if the TDF would not have been followed strictly, resulting in a more simplified overview of barriers and enablers. On the other hand, the advantage of using the TDF was that it enabled us to categorise barriers and enablers to an

encompassing, theory-based structure. It allowed the assessment of barriers and enablers from a broad perspective, thereby also exploring underexposed domains. Using a more simplified theoretical framework may have resulted in missing barriers and enablers in underexposed domains.

One single intervention versus multiple interventions

When selecting interventions aimed at promoting hospitalised patients' physical activity behaviour, clinicians and researchers can opt to develop, evaluate, and implement one single intervention versus multiple interventions at the same time. The latter is also referred to as multi-component, multi-faceted or multi-dimensional interventions in other studies³⁰⁻³². Given the large number of factors influencing the physical activity behaviour of hospitalised patients, introducing multiple interventions may increase the impact. Previous research suggests that developing and implementing multiple interventions may be more effective than introducing a single intervention³³. However, implementing multiple interventions makes investigating the effect of individual intervention components more challenging. Without taking the study design and potential confounding factors into consideration, the advantage of introducing a single intervention is that any effects can be ascertained to this intervention. In chapter 5, we therefore chose to investigate one single intervention. Due to differences in perspective, clinicians and researchers may make different choices. While clinicians may opt to introduce multiple interventions to increase the impact, researchers may prefer to investigate the effect of a single intervention.

Type of study design

In chapter 5 we used a non-randomised quasi-experimental study design to investigate whether introducing Hospital Fit as part of the standard physiotherapy treatment would result in a change in the amount of physical activity and functional recovery of patients undergoing elective orthopaedic surgery. This study design was chosen for practical reasons as it enabled us to effectively use the time in which Hospital Fit was developed to allocate included patients to the control group. This was followed by a one-month implementation phase during which no patients were enrolled. After this month, all subsequent patients were allocated to the intervention group. However, we acknowledge that with the chosen study design, the results may not only be attributable to the introduction of Hospital Fit. Although the clinical care pathway and physiotherapy treatment did not change during the study period, awareness on the importance of physical activity might have increased among patients and healthcare professionals, which may have resulted in a slight overestimation of the results.

Implications for clinical practice

The mission statement of the MUMC+ is 'to provide the best possible care and to create a healthier population in our region through connecting and integrating patient care, research and education'. Can we say that we provide the best possible care if patients spend more than 87% of the day lying in bed or sitting in a chair? Although the purpose of a hospital admission is to contribute to improved health or quality of life of patients, the inactivating hospital culture unintentionally contributes to negative health outcomes. Chastin et al. even stated that it is not acceptable that people are exposed to further health risks if they have to go to hospital[!]. Therefore hospitals need to change their inactivating culture into a (re)activating culture where promoting physical activity is high on the agenda of healthcare professionals.

However, the Dutch healthcare system is facing enormous pressure as a result of rising healthcare demands, imminent shortage of healthcare professionals and increasing healthcare expenses³⁴. Due to the aging population and increasing number of people with a chronic illness or multi-morbidity, the proportion of patients in need of more complex care is expected to further increase³⁵. In order to reduce costs while providing the same – or improved – quality of care, the Dutch ministry of Health, Welfare and Sport has initiated the program 'Right Care in the Right Place' (Dutch translation: Juiste Zorg op de Juiste Plek). This program aims to 1) prevent use of more expensive healthcare; 2) optimise the organisation of care around patients and relocate it closer to patients; 3) replace traditional care by smart technologies or eHealth where possible³⁵. In order to change the inactivating hospital culture and improve the physical activity behaviour of hospitalised patients, we should aim to select the right patients and offer them the right interventions by the right healthcare professional.

Selecting the right patients

In order to provide the right care in the right place, we need to determine which patients benefit most from interventions aimed at increasing their physical activity behaviour during hospitalisation. A proportion of patients will enter the hospital in a relatively healthy condition and good physical shape. Although their physical activity behaviour is likely to decrease during hospitalisation, their relatively large reserve capacity will reduce the risk of experiencing negative effects of inactivity within a hospital stay with an average length of stay of 5.2 days³⁶.

A number of patients are at higher risk of experiencing the negative effects of inactivity, such as older adults with pre-existing frailty and patients undergoing major surgery. Many of these patients already have a decreased reserve capacity resulting from sedentary behaviour prior to admission, multi-morbidity, or age-related impairments (e.g., malnutrition, cognitive impairment, incontinence, or

sensory impairment)⁷. These patients are likely to benefit most from targeted interventions aimed at increasing their physical activity behaviour.

When patients are admitted for acute hospital care, we aim to identify patients at high risk of spending little time active as soon as possible after admission. Prognostic tools such as the prediction model that was developed in chapter 4 can be used to identify patients at high risk. To improve outcomes, they can subsequently be given targeted interventions aimed at increasing their physical activity behaviour.

When patients are scheduled to receive major surgery, we should also use the period prior to hospital admission to intervene. These patients could be screened prior to admission. If necessary, they should be offered interventions aimed at optimising their physical activity behaviour, physical functioning and nutritional status prior to admission. This may include monitoring their physical activity levels or nutritional status through the use of eHealth (e.g., wearables). Through optimising patients' physical activity behaviour before, during and after hospitalisation we can aim to reduce healthcare expenses while improving the quality of care.

Providing the right interventions

Improving the physical activity behaviour of hospitalised patients is a complex problem that is influenced by many different factors interacting at individual and system levels. Due to this complexity, a 'one size fits all' intervention does not exist¹. Numerous different interventions could be offered to improve patients' physical activity behaviour. An eminent factor when aiming to change physical activity behaviour is early involvement of all relevant stakeholders, including patients. It is important that stakeholders are involved in the selection process of interventions as their support will influence the implementation and adoption. As such, they will ultimately determine the success of selected interventions.

The next step in selecting interventions is to gain insight in specific barriers and enablers that may influence the physical activity behaviour of hospitalised patients in a certain setting and population^{2,4,5}. Although most patient populations show high levels of sedentary behaviour, different patient populations and settings may require different interventions. Through tailoring interventions to the needs of specific patient populations, we can provide personalised and participatory care. Therefore, performing a setting specific analysis of barriers and enablers is recommended. In selecting which factors to target and choosing corresponding interventions, the APEASE criteria (affordability, practicability, effectiveness and cost-effectiveness, acceptability, side-effects/safety, equity) could be useful in making strategic judgements and choices³⁷.

As the prominent role of the domains ‘*Environmental Context and Resources*’, ‘*Knowledge*’ and ‘*Skills*’ and ‘*Social Influences*’ with respect to physical activity during hospitalisation is demonstrated in chapters 2 and 3, we suggest that clinicians and researchers should always consider incorporating these TDF domains in their interventions. Moreover, these domains predominantly contain factors that can be influenced directly. As described earlier, wicked problems are characterised by the influence of multiple interacting factors that influence each other. Factors that are deeply entangled and influenced by many other factors may be more difficult to influence than factors that can be directly influenced. In prioritising which factors to target, we propose to first focus on targeting factors that can be directly influenced. These may in turn exert a positive influence on more entangled factors. To provide some suggestions we have highlighted some key areas that may deserve special focus (Figure 7.1).

Environmental context and resources

Care processes and organisational characteristics

Many care processes and organisational characteristics are concentrated around the hospital bed, with patients waiting for physician and nursing rounds, therapy services, visitors, and distribution of food or medication. Interventions should focus on reducing ‘bed-centred care’ and stimulate ‘function-focused care’. Examples of suggested strategies are providing patients insight in their daily schedule, creating policy to eat in communal dining rooms, evaluating pain medication at structured moments, or creating policy that patients walk to the physician instead of the physician visiting every patient. To realise this, it is important to create a dedicated multidisciplinary team in which all healthcare professionals have the same ambition. Roles and responsibilities regarding physical activity promotion should be discussed and agreed upon within a multidisciplinary team. Moreover, policies should be reinforced by ward managers.

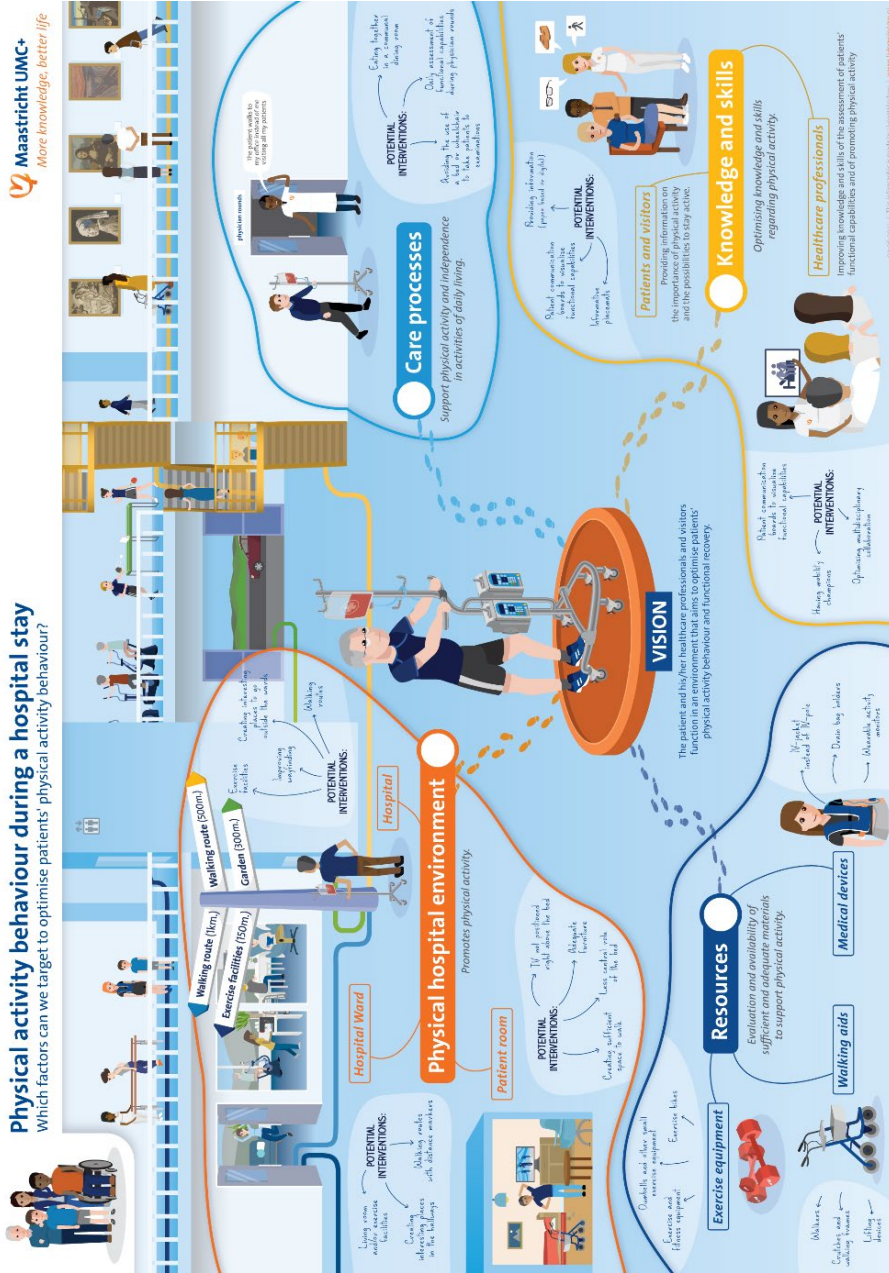

Figure 7.1 Overview of interventions aimed at promoting patients' physical activity behaviour during hospitalisation.

Resources

A prerequisite to enable physical activity is the availability of sufficient and adequate equipment (e.g., walking aids, lifting devices, exercise and fitness equipment, drain bag holders, or portable oxygen tanks). Without this equipment, patients are not able to get active. Therefore, interventions aimed at obtaining sufficient and adequate resources are essential. Furthermore, the availability of wearables to monitor patients' physical activity behaviour and to use in goal-setting is also essential. Chapter 5 supports this by showing that the use of Hospital Fit has resulted in an average increase in time spent standing and walking of 28 minutes in patients after elective orthopaedic surgery on postoperative day one compared to patients that did not use Hospital Fit. Interventions aimed at implementing objective physical activity monitoring in usual care are highly suggested.

The physical hospital environment

As the hospital environment exerts an inactivating influence on patients, interventions should aim to restructure the physical environment of the room, ward and hospital setting. As this may require substantial planning and resources, such interventions will likely need to be incorporated in the long term hospital renovation plans.

Knowledge

Interventions aimed at improving awareness of the importance of physical activity during hospitalisation are an important prerequisite to encourage patients to get active during hospitalisation. When patients lack awareness, they are not going to get active. Similarly, when healthcare professionals or visitors lack awareness, they are not going to encourage or assist patients. If patients are admitted for elective hospital care, they should be informed prior to hospitalisation. During hospitalisation, all patients should be informed regarding the importance of remaining as active as possible during hospitalisation. Moreover, they should also be informed regarding their functional capabilities, the available options to stay active, and their daily schedule. Suggested strategies to incorporate in interventions are using patient communication boards to visualise functional capabilities, providing patients with a daily schedule, and providing information face-to-face, via brochures, websites or TV.

Skills

Chapter 4 shows that being dependent on others during physical activity is associated with lower levels of physical activity. In order to increase the physical activity behaviour of patients in need of assistance, interventions are needed that involve volunteers, students, nursing assistants or visitors in promoting physical activity on a structural basis. Moreover, interventions should also focus on

improving the skills of healthcare professionals and other persons assisting patients during physical activity. They should have the skills to assist patients and should feel confident in using walking aids and lifting devices. Suggested strategies to improve these skills are providing regular skills training sessions and using mobility champions.

Promoting physical activity by the right healthcare professional

Due to their expertise, promoting physical activity during hospitalisation is generally attributed to physiotherapists. However, chapters 2 and 3 show that changing the physical activity behaviour of hospitalised patients is a complex problem that is influenced by many different factors. Many of these factors are not influenced by physiotherapy. A large number of inactive patients have the ability to get out of bed and walk around without assistance, but are inactive for other reasons. However, being inactive does not equal that there is an indication for physiotherapy. To provide the right care by the right person, other healthcare professionals, (e.g., nurses, nursing assistants, physicians, hospital management), visitors and volunteers also play an important role in promoting physical activity. Promoting physical activity should be a multidisciplinary responsibility in which everyone's roles and responsibilities are clear. It is important that roles and responsibilities are attributed to the person that can either provide the best care in a certain situation, or that can provide the same quality of care at a lower cost.

Recommendations for future research

Further development of Hospital Fit

Based on this thesis, multiple recommendations for future research can be made. In our pilot study in chapter 5 we demonstrated that Hospital Fit has potential to improve physical activity behaviour and enhance recovery of hospitalised patients. Future research with a stronger study design in a population with a longer length of hospital stay is advised to determine the effectiveness of Hospital Fit. Moreover, the study also resulted in suggestions for improvement of Hospital Fit. One of these suggestions was to embed the accelerometer algorithm described in chapter 6 into Hospital Fit to enable differentiating standing from walking and to allow measuring postural transitions. Additionally, adding a goal setting function and reminder function were suggested, as well as providing more information regarding the importance of physical activity during hospitalisation. Through collaboration between MUMC+, Maastricht University and Maastricht Instruments B.V., a Top Consortia for Knowledge and Innovation's - Life Sciences & Health (TKI-LSH) public-private partnership (PPP) allowance was granted to realise these suggestions. The effect of using the improved Hospital Fit during physiotherapy is currently studied in an assessor blinded randomised controlled trial (RCT) in 78 patients hospitalised at the department of Internal Medicine or the department of Pulmonology.

Furthermore, to enhance patients' physical activity behaviour and functional recovery, the data generated by Hospital Fit should not only be available to patients and physiotherapists, but also to other healthcare professionals. Linking the data to the patients' electronic medical record would enable this. More funding was raised through the Academic Alliance Fund to perform a multi-centre trial in which the data of Hospital Fit is linked to the electronic medical record. Between June 2022 and February 2023, a stepped-wedge cluster randomised trial will be performed to investigate the effectiveness of Hospital Fit in 180 patients hospitalised at the Medical Oncology or Cardiology wards of the Radboudumc and MUMC+. To create a better understanding of the intervention effect, a process evaluation will be performed additionally through using the RE-AIM (reach, effectiveness, adoption, implementation, maintenance) framework³⁸.

How much physical activity is needed to prevent negative outcomes?

To investigate how much physical activity is needed to prevent the negative effects of inactivity, we would recommend to conduct a fundamental study in a homogeneous patient population to gain insight in the decline in muscle mass and/or muscle strength in relation to patients' physical activity behaviour during a hospital stay.

Interventions aimed at improving hospitalised older adults' physical activity behaviour

So far, evidence for the efficacy or effectiveness of interventions aimed at promoting physical activity in hospitalised older adults is found inconsistent due to a heterogeneous population, large variety in interventions, and lack of detailed reporting of intervention components³⁹⁻⁴⁴. Our overview of barriers and enablers to physical activity in hospitalised patients provides a first step towards identifying potentially modifiable factors and developing targeted interventions aimed at increasing older adults' physical activity behaviour during hospitalisation. Further high quality trials are needed to investigate the effect of such interventions, with detailed reporting of frequency, intensity and duration^{39,44}. To create a better understanding of the intervention effect, performing a process evaluation is advised as well.

Patient-specific assessment of barriers and enablers to physical activity during hospitalisation

Lastly, patients' physical activity behaviour can be influenced by many different factors. In order to provide preventative, personalised and participatory care it would be of added value if healthcare professionals had a tool (e.g., questionnaire) that could be administered shortly after admission and that could easily provide them insight in specific factors that influence the physical activity behaviour of

individual patients. Subsequently, these patients can be offered personalised interventions. Future research is recommended to develop, validate and evaluate such a patient-specific assessment tool.

GENERAL CONCLUSION

This thesis has resulted in an improved understanding of all the factors that influence patients' physical activity behaviour during hospitalisation. The TDF-based overview of barriers and enablers provides a theoretical foundation to guide clinicians and researchers in future intervention development and implementation. Moreover, a setting specific analysis of barriers and enablers to physical activity in older adults admitted to the MUMC+ with an acute medical illness has provided a first step towards developing, evaluating and implementing theory-informed behaviour change interventions to improve the physical activity behaviour of these patients. The developed and internally validated prediction models may enable clinicians to identify older adults that are likely to benefit most from such interventions. This thesis has also shown that a smartphone app combined with an accelerometer demonstrates potential to enhance patients' physical activity behaviour and speed of recovery during hospitalisation. To further improve physical activity monitoring in hospitalised patients, a physical activity algorithm was created and validated that is able to classify sedentary and dynamic activities as well as to detect postural transitions under free-living conditions in hospitalised patients. Overall, we can conclude that this thesis has provided valuable contributions to improve patients' physical activity behaviour during hospitalisation.

REFERENCES

1. Chastin SFM, Harvey, J.A., Dall, P.M.,McInally, L., Mavroeydi, A., Skelton, D.A. Beyond "sedentary behaviour", tackling sedentary behaviour in health care. *AIMS Med Sci.* 2019;6(1):67-75.
2. Moore JE, Mascarenhas A, Marquez C, Almaawiy U, Chan WH, D'Souza J, et al. Mapping barriers and intervention activities to behaviour change theory for Mobilization of Vulnerable Elders in Ontario (MOVE ON), a multi-site implementation intervention in acute care hospitals. *Implement Sci.* 2014;9:160.
3. So C, Pierluissi E. Attitudes and expectations regarding exercise in the hospital of hospitalized older adults: a qualitative study. *J Am Geriatr Soc.* 2012;60(4):713-8.
4. Dermody G, Kovach CR. Barriers to Promoting Mobility in Hospitalized Older Adults. *Res Gerontol Nurs.* 2018;11(1):17-27.
5. Michie S JM, Francis J, Hardeman W, Eccles M. From Theory to Intervention: Mapping Theoretically Derived Behavioural Determinants to Behaviour Change Techniques. *Appl Psychol.* 2008;57(4):660-80.
6. Hoogeboom TJD, J.J.; Hulzebos, E.H.; van Meeteren, N.L. Merits of exercise therapy before and after major surgery. *Curr Opin Anaesthesiol.* 2014;27.
7. Buurman BM, Hoogerduijn JG, de Haan RJ, Abu-Hanna A, Lagaay AM, Verhaar HJ, et al. Geriatric conditions in acutely hospitalized older patients: prevalence and one-year survival and functional decline. *PLoS One.* 2011;6(11):e26951.
8. Delft LMMv. Promoting inpatients' physical activity. From the development of a family participation intervention to the implementation of a multidimensional action plan. Utrecht, the Netherlands: Utrecht University; 2021.
9. Hartley P, DeWitt AL, Forsyth F, Romero-Ortuno R, Deaton C. Predictors of physical activity in older adults early in an emergency hospital admission: a prospective cohort study. *BMC Geriatr.* 2020;20(1):177.
10. Tasheva P, Kraege V, Vollenweider P, Roulet G, Méan M, Marques-Vidal P. Accelerometry assessed physical activity of older adults hospitalized with acute medical illness - an observational study. *BMC Geriatr.* 2020;20(1):382.
11. Baldwin C, van Kessel G, Phillips A, Johnston K. Accelerometry Shows Inpatients With Acute Medical or Surgical Conditions Spend Little Time Upright and Are Highly Sedentary: Systematic Review. *Phys Ther.* 2017;97(11):1044-65.
12. Baldwin CE, Phillips AC, Edney SM, Lewis LK. Recommendations for older adults' physical activity and sedentary behaviour during hospitalisation for an acute medical illness: an international Delphi study. *Int J Behav Nutr Phys Act.* 2020;17(1):69.
13. Ley L, Khaw D, Duke M, Botti M. The dose of physical activity to minimise functional decline in older general medical patients receiving 24-hr acute care: A systematic scoping review. *J Clin Nurs.* 2019;28(17-18):3049-64.
14. Resnick B, Boltz M. Optimizing Function and Physical Activity in Hospitalized Older Adults to Prevent Functional Decline and Falls. *Clin Geriatr Med.* 2019;35(2):237-51.
15. Fazio S, Stocking J, Kuhn B, Doroy A, Blackmon E, Young HM, et al. How much do hospitalized adults move? A systematic review and meta-analysis. *Applied nursing research : ANR.* 2020;51:151189.
16. Fini NA, Holland AE, Keating J, Simek J, Bernhardt J. How Physically Active Are People Following Stroke? Systematic Review and Quantitative Synthesis. *Phys Ther.* 2017;97(7):707-17.
17. Ekegren CL, Beck B, Climie RE, Owen N, Dunstan DW, Gabbe BJ. Physical Activity and Sedentary Behavior Subsequent to Serious Orthopedic Injury: A Systematic Review. *Arch Phys Med Rehabil.* 2018;99(1):164-77.e6.
18. Bull FC, Al-Ansari SS, Biddle S, Borodulin K, Buman MP, Cardon G, et al. World Health Organization 2020 guidelines on physical activity and sedentary behaviour. *Br J Sports Med.* 2020;54(24):1451-62.
19. Brown CJ, Redden DT, Flood KL, Allman RM. The underrecognized epidemic of low mobility during hospitalization of older adults. *J Am Geriatr Soc.* 2009;57(9):1660-5.
20. Ostir GV, Berges IM, Kuo YF, Goodwin JS, Fisher SR, Guralnik JM. Mobility activity and its value as a prognostic indicator of survival in hospitalized older adults. *J Am Geriatr Soc.* 2013;61(4):551-7.
21. Fisher SR, Goodwin JS, Protas EJ, Kuo YF, Graham JE, Ottenbacher KJ, et al. Ambulatory activity of older adults hospitalized with acute medical illness. *J Am Geriatr Soc.* 2011;59(1):91-5.

22. Pedersen MM, Bodilsen AC, Petersen J, Beyer N, Andersen O, Lawson-Smith L, et al. Twenty-four-hour mobility during acute hospitalization in older medical patients. *J Gerontol A Biol Sci Med Sci*. 2013;68(3):331-7.
23. Evensen S, Sletvold O, Lydersen S, Taraldsen K. Physical activity among hospitalized older adults - an observational study. *BMC Geriatr*. 2017;17(1):110.
24. Villumsen M, Jorgensen MG, Andreasen J, Rathleff MS, Molgaard CM. Very Low Levels of Physical Activity in Older Patients During Hospitalization at an Acute Geriatric Ward: A Prospective Cohort Study. *J Aging Physical Activity*. 2015;23(4):542-9.
25. Pavon JM, Sloane RJ, Pieper CF, Colón-Emeric CS, Cohen HJ, Gallagher D, et al. Accelerometer-Measured Hospital Physical Activity and Hospital-Acquired Disability in Older Adults. *J Am Geriatr Soc*. 2020;68(2):261-5.
26. Craig P, Dieppe P, Macintyre S, Michie S, Nazareth I, Petticrew M. Developing and evaluating complex interventions: the new Medical Research Council guidance. *BMJ*. 2008;337:a1655.
27. McGowan LJ, Powell R, French DP. How can use of the Theoretical Domains Framework be optimized in qualitative research? A rapid systematic review. *Br J Health Psychol*. 2020;25(3):677-94.
28. Weatherson KA, McKay R, Gainforth HL, Jung ME. Barriers and facilitators to the implementation of a school-based physical activity policy in Canada: application of the theoretical domains framework. *BMC Public Health*. 2017;17(1):835.
29. Phillips CJ, Marshall AP, Chaves NJ, Jankelowitz SK, Lin IB, Loy CT, et al. Experiences of using the Theoretical Domains Framework across diverse clinical environments: a qualitative study. *J Multidiscip Healthc*. 2015;8:139-46.
30. van Delft LMM, Bor P, Valkenet K, Veenhof C. Hospital in Motion, a Multidimensional Implementation Project to Improve Patients' Physical Behavior During Hospitalization: Protocol for a Mixed-Methods Study. *JMIR Res Protoc*. 2019;8(4):e11341.
31. Conijn D, van Bodegom-Vos L, Volker WG, Mertens B, Vermeulen HM, Huurman V, et al. A multicomponent intervention to decrease sedentary time during hospitalization: a quasi-experimental pilot study. *Clin Rehabil*. 2020;34(7):901-15.
32. Koenders N, Potkamp-Kloppers S, Geurts Y, Akkermans R, Nijhuis-van der Sanden MWG, Hoogeboom TJ. Ban Bedcentricity: A Multifaceted Innovation to Reduce Sedentary Behavior of Patients During the Hospital Stay. *Phys Ther*. 2021;101(7).
33. Prior M, Guerin M, Grimmer-Somers K. The effectiveness of clinical guideline implementation strategies--a synthesis of systematic review findings. *J Eval Clin Pract*. 2008;14(5):888-97.
34. Volksgezondheid Rv. *Lerende Evaluatie Juiste Zorg Op de Juiste Plek - Plan van aanpak op hoofdlijnen*. Bilthoven; 2020 april 2020.
35. Taskforce Juiste Zorg op de Juiste Plek - Ministerie van Volksgezondheid WeS. *De juiste zorg op de juiste plek*. 2018.
36. Van Dijk-Huisman HC. CBS. StatLine - Ziekenhuisopnamen en patiënten; diagnose-indeling ICD-10 [Available from: <https://www.cbs.nl>].
37. Michie S, Atkins L, West R. *The Behaviour Change Wheel: A Guide to Designing Interventions*. 1st ed. United Kingdom: Silverback Publishing; 2014.
38. Glasgow RE, Vogt TM, Boles SM. Evaluating the public health impact of health promotion interventions: the RE-AIM framework. *Am J Public Health*. 1999;89(9):1322-7.
39. Kanach FA, Pastva AM, Hall KS, Pavon JM, Morey MC. Effects of Structured Exercise Interventions for Older Adults Hospitalized With Acute Medical Illness: A Systematic Review. *J Aging Physical Activity*. 2018;26(2):284-303.
40. de Morton NA, Keating JL, Jeffs K. The effect of exercise on outcomes for older acute medical inpatients compared with control or alternative treatments: a systematic review of randomized controlled trials. *Clin Rehabil*. 2007;21(1):3-16.
41. Scheerman K, Raaijmakers K, Otten RHJ, Meskers CGM, Maier AB. Effect of physical interventions on physical performance and physical activity in older patients during hospitalization: a systematic review. *BMC Geriatr*. 2018;18(1):288.
42. Martínez-Velilla N, Cadore EL, Casas-Herrero Á, Idoate-Saralegui F, Izquierdo M. Physical Activity and Early Rehabilitation in Hospitalized Elderly Medical Patients: Systematic Review of Randomized Clinical Trials. *J Nutr Health Aging*. 2016;20(7):738-51.

43. Kosse NM, Dutmer AL, Dasenbrock L, Bauer JM, Lamoth CJ. Effectiveness and feasibility of early physical rehabilitation programs for geriatric hospitalized patients: a systematic review. *BMC Geriatr.* 2013;13:107.
44. de Morton NA, Keating JL, Jeffs K. Exercise for acutely hospitalised older medical patients. *Cochrane Database Syst Rev.* 2007(1):Cd005955.



ADDENDUM

IMPACT PARAGRAPH

IMPACT PARAGRAPH

Inactive behaviour is common in patients during hospital stay and is associated with negative outcomes for patients, healthcare professionals, and healthcare costs. The results of this thesis contribute to the prevention of these negative effects. We created an overview of barriers and enablers that influence physical activity behaviour of hospitalised patients as reported by patients and healthcare professionals in previous research. The Theoretical Domains Framework (TDF) was adopted to categorise barriers and enablers. The overview provides a theoretical foundation for the development, evaluation and implementation of future interventions aimed at promoting physical activity during hospitalisation. Because barriers and enablers may differ between settings and populations, we also performed a setting-specific analysis in older adults admitted to the department of Internal Medicine of Maastricht University Medical Centre (MUMC+) for acute medical illness. These older adults are at high risk for negative outcomes during their hospital stay. The setting-specific analysis provides a starting point to help clinicians and researchers to select modifiable factors and choose corresponding interventions for this specific population and setting.

Because offering interventions to every patient may require substantial resources, we wanted to be able to select patients that are the least active and that are likely to benefit most from interventions aimed at improving their physical activity behaviour. The screening tool we developed can be used early after admission to identify older adults with an acute medical illness that are at high risk of spending little time standing and walking during their hospital stay. Those patients subsequently can be given interventions aimed at increasing their time standing and walking. As such, the screening tool can contribute to improved patient outcomes as well as value-based healthcare. Although the results look promising, determining the external validity and clinical impact are needed before applying the screening tool in clinical practice.

This thesis also contributed to the development and evaluation of Hospital Fit, an innovative intervention consisting of a smartphone based app connected to a wearable activity monitor. Hospital Fit is one of the first medical devices that is able to validly measure physical activity behaviour of hospitalised patients while also providing real-time feedback to patients and healthcare professionals. Hospital Fit has the potential to enhance physical activity behaviour and functional recovery of hospitalised patients admitted for elective orthopaedic surgery. However, its effects might even be superior in patients with a relatively longer length of hospital stay. Because Hospital Fit enables generating physical activity data in usual care, it can be of great added value for future data driven care. Moreover, this thesis advanced physical activity monitoring of hospitalised patients through optimising and

validating an accelerometer algorithm. The optimised algorithm is able to distinguish between standing and walking (dynamic) behaviour and to detect postural transitions from lying/sitting to standing/walking activities under real life conditions.

Generating knowledge, innovating healthcare and creating value

The MUMC+ strives to provide the best possible care and improve health in the region by integrating patient care, research and education. The MUMC+ innovation circle is a model that depicts how clinicians and researchers can create a healthier population through generating knowledge, innovating healthcare and creating value. This thesis followed the principles of the MUMC+ innovation circle.

Generating knowledge

The knowledge generated in this thesis can be used both within the MUMC+ as well as in other hospitals. Within the MUMC+, the findings of this thesis were shared with many different healthcare professionals (e.g., physiotherapists, nurses, physicians, clinical nurse specialists, managers). In 2018, 'Zorg dat u beweegt' was created, an initiative of a group of enthusiastic physiotherapists who's aim it was to create awareness of the importance of physical activity (behaviour) during hospitalisation among patients, visitors and other healthcare professionals. We developed, evaluated and implemented a number of interventions aimed at preventing the negative effects associated with inactivity. Because of increasing awareness and support throughout the hospital, the MUMC+ Healthcare Innovation Lab incorporated 'Physical activity and Nutrition' in their program in 2019, which enabled the development, evaluation and implementation of innovative interventions on a larger scale. The overview of barriers and enablers created in this thesis was used to assist with the selection of interventions. Moreover, knowledge generated in this thesis is used as input for the steering committee 'Nutrition and Physical Activity' (i.e., 'Stuurgroep Herstelvoeding en Beweging') and the strategic program (i.e., 'Onze Zorg van de Toekomst'). We aim that the process of developing, evaluating, and implementing physical activity promoting interventions will be embedded in the organisational structure of the MUMC+ in the near future.

Knowledge dissemination of the results of this thesis was also realised through presentations at national and international conferences, in professional and scientific journals, and by giving an annual lecture on physical activity monitoring at the bachelor's program Health Sciences of Maastricht University. Moreover, this thesis has provided opportunities for many students of the bachelor's program Physiotherapy, and master's programmes in Geriatric Physiotherapy, Human

Movement Sciences, and Health Policy, Innovation and Management, to conduct their thesis research projects.

Lastly, knowledge was also shared with other hospitals through participation in the expert group 'Bewegziekenhuizen'. This expert group is composed of nine pioneering Dutch hospitals that have each initiated and evaluated innovative and/or multifaceted projects aimed at promoting physical activity during hospitalisation. Since we all pursue the same goal, we aim to inspire and strengthen each other by sharing knowledge and experiences of our successes and failures. Moreover, we discuss knowledge gaps and where possible collaborate in research. These research collaborations have resulted in joint conference presentations, a shared publication with the AmsterdamUMC, Amsterdam and funding for a future study performed in collaboration with the Radboudumc, Nijmegen. We disseminate our knowledge and experiences through the 'Royal Dutch Society for Physiotherapy (KNGF) Standpunt Bewegziekenhuizen' and through organising a course that educates other hospitals on how to change their inactivating hospital culture.

Innovating healthcare

Our research findings have innovated healthcare through the development and evaluation of Hospital Fit, an optimised accelerometer algorithm, and a screening tool that can be used to identify older adults at high risk for low physical activity levels. These innovations have been developed and evaluated in close collaboration with the MUMC+, Maastricht University and its partners Maastricht Instruments B.V., IDEE and MEMIC. Through this partnership we have acquired funding to further improve and investigate Hospital Fit. These improvements consist of embedding the optimised algorithm in Hospital Fit, adding information regarding the importance of physical activity during hospitalisation, and adding a goal setting- and reminder function. Additionally, we have created a link that allows data created by Hospital Fit to be sent to the patient's electronic health record, making it accessible to other healthcare professionals within the multidisciplinary care team as well. Moreover, funding raised through the Academic Alliance has enabled us to introduce and further investigate Hospital Fit in the Radboudumc in a multi-centre study.

Furthermore, the results of this thesis have indirectly contributed to innovated healthcare through the development, evaluation and implementation of multiple innovative interventions within the MUMC+, such as patient communication boards that visualise functional capabilities (i.e., Bewegbord), an interactive biking system, a walking route, and 'Exercise Boxes' designed for patients that are unable to leave their room.

The knowledge and innovations generated in this thesis is directly implementable in clinical care. It has created value for patients, healthcare professionals and

healthcare costs and contributes to 'Providing the right care at the right place' as well as providing 'Predictive, preventative, personalised and participatory care (P4-Medicine). Moreover, this thesis supports the mission of the MUMC+ as it contributes to providing the best possible care and improving health in the region by integrating patient care, research, and education.



ADDENDUM

SUMMARY

SUMMARY

Inactive behaviour is common during hospital stay. On average, patients spend between 87% and 100% of their day lying in bed or sitting in a chair. Moreover, bouts of standing and walking are usually short and prolonged periods of uninterrupted sedentary behaviour are common. This inactive behaviour is associated with negative health outcomes such as functional decline, complications, an increased length of hospital stay, an increased risk of institutionalisation, and mortality. Previous research has shown that these negative health outcomes can be counteracted by improving patients' physical activity behaviour. To improve outcomes, it is therefore essential that hospitalised patients remain as active as their abilities allow.

During hospital stay, patients are temporarily taken out of their own environment. They enter an unfamiliar environment in which they may miss their usual daily routines. The hospital environment is not primarily designed to promote physical activity. Many care processes are concentrated around the hospital bed, with patients remaining in their rooms, waiting for physician and nursing rounds, examinations or distribution of food and medication. Additionally, patients may feel unwell and may be dependent on healthcare professionals to receive care. As such, a hospital stay can be associated with many uncertainties and insecurities. For many patients, their main focus is getting better and getting home, and less attention is being paid on being physically active. To decrease negative effects associated with inactivity, hospitals should aim to change their culture from an inactivating to a (re)activating hospital. Moreover, interventions aimed at improving physical activity behaviour of hospitalised patients are needed. The main aim of this thesis is to contribute to improving patients' physical activity behaviour during hospitalisation.

In chapter 2, a scoping review was performed to create an overview of all published patient- and healthcare professional-reported barriers and enablers to physical activity during a hospital stay for acute care. The Theoretical Domains Framework (TDF) was used as a theoretical framework to categorise identified barriers and enablers. Fifty-six quantitative, qualitative, and mixed-methods studies were included in the review. In total, 264 barriers and 228 enablers were reported by patients, and 415 barriers and 409 enablers by healthcare professionals. The large number of identified barriers and enablers demonstrate the complexity of changing patients' physical activity behaviour during hospital stay. Barriers and enablers were most frequently assigned to the TDF domains '*Environmental Context and Resources*' and '*Social Influences*'. This highlights the need for interventions that target the physical environment, hospital care processes and organisational factors, patient-related factors, resources, and the social influence on patients, healthcare

professionals and visitors. The comprehensive overview of barriers and enablers provides a foundation to guide clinicians and researchers during future development, evaluation and implementation of interventions aimed at promoting physical activity during hospitalisation.

Older adults admitted with an acute medical illness spend little time active during hospitalisation and this has been associated with negative health outcomes. In chapter 3, a qualitative study was conducted to explore patient- and healthcare professional-perceived barriers and enablers to physical activity behaviour in older adults admitted for acute medical illness to the Department of Internal Medicine of Maastricht University Medical Centre (MUMC+). Semi-structured interviews were conducted with 12 patients and 16 healthcare professionals (nurses, physicians, and physiotherapists). Interviews were analysed using directed qualitative content analysis and barriers and enablers were coded and categorised using the TDF. A large number of barriers and enablers were identified and spread over 11 of the 14 TDF domains, again showing the complexity of influencing older adults' physical activity behaviour during hospitalisation. The domain '*Environmental Context and Resources*' in particular yielded many factors and revealed that the hospital environment exerts an inactivating influence on patients. The setting-specific overview created in this study represents an initial step towards developing, evaluating and implementing theory-informed behaviour change interventions to improve hospitalised older adults' physical activity levels. It can assist clinicians and researchers in selecting modifiable factors that can be targeted in future interventions.

Chapter 4 aimed to develop a screening tool to identify older adults at high risk of spending little time active during hospitalisation. In this prospective cohort study, two prediction models were developed and internally validated to predict the probability of spending little time standing and walking during hospitalisation. Physical activity was measured with an accelerometer in 165 patients until discharge (≤ 12 days). Potential predictors - Short Physical Performance Battery (SPPB), Activity Measure for Post-Acute Care (AM-PAC), age, sex, walking aid use, and disabilities in activities of daily living - were preselected based on published studies reporting factors associated with inactive behaviour of older adults admitted to a hospital with an acute medical illness. Model 1 predicts the probability of spending ≤ 64.4 minutes standing and walking, and holds the predictors SPPB, AM-PAC and sex. Model 2 predicts the probability of spending ≤ 47.2 minutes standing and walking, and holds the predictors SPPB, AM-PAC, age and walking aid use. Both models demonstrate near perfect calibration of the predicted probabilities and good overall performance, with model 2 performing slightly better. The developed and internally validated prediction models may enable clinicians to identify older

adults at high risk of spending little time standing and walking during hospitalisation.

Chapter 5 investigated the potential of Hospital Fit to enhance physical activity levels and functional recovery following orthopaedic surgery. Hospital Fit consists of a smartphone application connected to an accelerometer. It enables objective physical activity monitoring, provides patients with insight into their recovery progress, and offers a tailored exercise program. A pilot study was conducted in 97 patients undergoing total knee or hip arthroplasty using a non-randomised quasi-experimental design. Patients allocated to the control group received usual care physiotherapy while patients allocated to the intervention group additionally used Hospital Fit. Physical activity (time spent standing/walking per day) was measured with an accelerometer postoperatively until discharge. Functional recovery on postoperative day one (POD1) was measured using the modified Iowa Level of Assistance Scale (mILAS). Hospital Fit use, corrected for age, resulted in an average increase of 28.43 min (95% confidence interval (CI): 5.55–51.32) standing and walking on POD1. Moreover, the odds of achieving functional recovery on POD1, corrected for the American Society of Anesthesiologists classification, were 3.08 times higher (95% CI: 1.14–8.31) with Hospital Fit use. This pilot study shows that Hospital Fit demonstrates the potential to enhance patients' physical activity levels and functional recovery during hospitalisation.

In chapter 6, an accelerometer algorithm was optimised and validated that discriminates between sedentary, standing, and dynamic activities, and records postural transitions in hospitalised patients. Accelerometer data was collected under free-living conditions and compared to video analysis in orthopaedic and acutely hospitalised elderly patients. Data of 25 patients was used to optimise the algorithm, data of another 25 patients was used for the validation. Optimisation resulted in the best performance with parameter settings: WS 4 s, PA Th 4.3 counts per second, SO Th 0.8 g. Validation showed that the algorithm classified all activities within acceptable limits (>80% sensitivity, specificity and accuracy, $\pm 10\%$ error), except for standing activity. The optimised algorithm is considered suitable to classify physical activity in hospitalised patients.

In the general discussion in chapter 7, the main findings and methodological considerations of this thesis are discussed. Furthermore, implications for clinical practice and recommendations for future research are presented.

In conclusion, this thesis has resulted in an improved understanding of all the factors that influence patients' physical activity behaviour during hospitalisation. It has provided valuable contributions to improve patients' physical activity behaviour during hospitalisation.



ADDENDUM

SAMENVATTING

SAMENVATTING

Fysieke inactiviteit komt regelmatig voor tijdens een ziekenhuisopname. Patiënten brengen gemiddeld 87% tot 100% van de dag liggend in bed of zittend in een stoel door. Perioden van staan en lopen zijn meestal van korte duur en perioden van ononderbroken inactiviteit vaak lang. Dit sedentaire gedrag is geassocieerd met negatieve gezondheidsuitkomsten, zoals functionele achteruitgang, complicaties, een langere verblijfsduur in het ziekenhuis, een verhoogde kans op zowel opname in een instelling als mortaliteit. Eerder onderzoek heeft aangetoond dat deze negatieve gezondheidsuitkomsten kunnen worden tegengegaan door het stimuleren van fysieke activiteit. Om de gezondheidsuitkomsten te verbeteren, is het daarom belangrijk dat patiënten tijdens een ziekenhuisopname zo actief mogelijk blijven.

Tijdens een ziekenhuisopname worden patiënten tijdelijk uit hun eigen omgeving gehaald. Ze komen in een vreemde omgeving terecht waarin ze hun gebruikelijke dagelijkse routines vaak niet kunnen voortzetten. De ziekenhuisomgeving is niet primair gericht op het stimuleren van fysieke activiteit. Veel zorgprocessen vinden plaats rondom het ziekenhuisbed. Patiënten blijven vaak aan bed gekluisterd, wachten op de artsensite, onderzoeken, eten en drinken of medicatie. Bovendien kunnen ze zich ziek voelen of afhankelijk zijn van zorgprofessionals om te kunnen bewegen. Een ziekenhuisverblijf kan daarom gepaard gaan met veel onzekerheden. Voor veel patiënten ligt de primaire focus op herstel en weer terug naar huis kunnen, en veel minder op fysiek actief blijven. Om de negatieve gevolgen van inactiviteit tegen te gaan, moeten ziekenhuisorganisaties ernaar streven te veranderen van een deactiverende naar een (re)activerende ziekenhuiscultuur. Er is behoefte aan interventies gericht op het stimuleren van fysieke activiteit van patiënten tijdens een ziekenhuisopname. De primaire doelstelling van dit proefschrift is om een bijdrage te leveren aan het stimuleren van fysieke activiteit van patiënten tijdens ziekenhuisopname.

In hoofdstuk 2 is een scoping review uitgevoerd om een overzicht te creëren van alle belemmerende en stimulerende factoren ten aanzien van fysieke activiteit tijdens een ziekenhuisopname, zoals door patiënten en zorgprofessionals in de literatuur beschreven. Het Theoretical Domains Framework (TDF) is gebruikt als theoretisch raamwerk om alle belemmerende en stimulerende factoren te categoriseren. Zesenvijftig kwantitatieve, kwalitatieve en mixed-methods studies zijn in de review opgenomen. In totaal werden 264 belemmerende- en 228 stimulerende factoren gevonden die door patiënten beschreven waren, en 415 belemmerende- en 409 stimulerende factoren door zorgprofessionals. Het grote aantal geïdentificeerde belemmerende en stimulerende factoren toont de complexiteit aan van het veranderen van het beweeggedrag van patiënten tijdens een

ziekenhuisopname. Belemmerende en stimulerende factoren werden het vaakst toegewezen aan de TDF-domeinen '*Omgevingsfactoren en Middelen*' en '*Sociale invloeden*'. Dit wijst op de noodzaak om interventies te richten op het veranderen van de fysieke omgeving van het ziekenhuis, zorgprocessen en organisatorische factoren in het ziekenhuis, de beschikbaarheid van middelen, patiënt-gerelateerde factoren, en de sociale invloed die uitgeoefend wordt op patiënten, zorgprofessionals en bezoekers. Het uitgebreide overzicht van belemmerende en stimulerende factoren biedt een basis om klinici en onderzoekers te begeleiden bij de toekomstige ontwikkeling, evaluatie en implementatie van interventies gericht op het stimuleren van fysieke activiteit tijdens een ziekenhuisopname.

Ouderen die zijn opgenomen voor een acute medische aandoening brengen weinig tijd fysiek actief door tijdens de opname en dit is geassocieerd met negatieve gezondheidsuitkomsten. In hoofdstuk 3 is een kwalitatieve studie uitgevoerd waarin belemmerende- en stimulerende factoren onderzocht zijn ten aanzien van fysieke activiteit bij ouderen die met een acute medische aandoening waren opgenomen op de afdeling Interne- en Ouderengeneeskunde van het Maastricht Universitair Medisch Centrum (MUMC+). Semi-gestructureerde interviews werden afgenomen met 12 patiënten en 16 zorgprofessionals (verpleegkundigen, artsen en fysiotherapeuten). De interviews werden geanalyseerd met behulp van 'directed qualitative content analysis'. Belemmerende en stimulerende factoren werden gecodeerd en gecategoriseerd met behulp van het TDF raamwerk. Er werd een groot aantal belemmerende factoren en stimulerende factoren geïdentificeerd en deze werden vervolgens gecategoriseerd over 11 van de 14 TDF domeinen. Het grote aantal factoren toont nogmaals de complexiteit aan van het veranderen van het beweeggedrag van acut opgenomen ouderen tijdens een ziekenhuisopname. Met name het domein '*Omgevingsfactoren en Middelen*' leverde veel factoren op en benadrukt de inactiverende invloed van de ziekenhuisomgeving op patiënten. Het setting-specifieke overzicht dat in deze studie is gecreëerd, is een eerste stap op weg naar het ontwikkelen, evalueren en implementeren van theorie-onderbouwde gedragsveranderingsinterventies gericht op het stimuleren van fysieke activiteit van acut opgenomen ouderen tijdens een ziekenhuisopname. Het overzicht kan klinici en onderzoekers helpen in de selectie van modificeerbare factoren die in toekomstige interventies kunnen worden aangepakt.

Hoofdstuk 4 had als doelstelling een screeningsinstrument te ontwikkelen waarmee acut opgenomen ouderen geïdentificeerd kunnen worden die een hoog risico lopen om weinig tijd actief te zijn tijdens een ziekenhuisopname. In deze prospectieve cohortstudie werden twee predictiemodellen ontwikkeld en intern gevalideerd om de kans op het weinig fysiek actief zijn tijdens een ziekenhuisopname te voorspellen. Fysieke activiteit werd gemeten met een accelerometert bij 165 patiënten van inclusie tot ontslag uit het ziekenhuis (≤ 12 dagen). Potentiële

predictoren - Short Physical Performance Battery (SPPB), Activity Measure for Post-Acute Care (AM-PAC), leeftijd, geslacht, gebruik van loophulpmiddelen, en beperkingen in activiteiten van het dagelijks leven - werden voorgeselecteerd op basis van gepubliceerde studies waarin factoren gerapporteerd werden die geassocieerd zijn met inactiviteit bij acuut opgenomen ouderen. Model 1 voorspelt de kans op minder dan 64,4 minuten staan en lopen, en bevat de predictoren SPPB, AM-PAC en geslacht. Model 2 voorspelt de kans op minder dan 47,2 minuten staan en lopen, en bevat de predictoren SPPB, AM-PAC, leeftijd en gebruik van loophulpmiddelen. Beide modellen vertonen een bijna perfecte schatting van de voorspelde kansen en goede algemene prestaties van de modellen, waarbij model 2 iets beter presteert. De ontwikkelde en intern gevalideerde predictiemodellen kunnen klinici in staat stellen om acuut opgenomen ouderen te identificeren die een hoog risico lopen om weinig tijd fysiek actief door te brengen tijdens een ziekenhuisopname.

Hoofdstuk 5 onderzocht het potentieel van Hospital Fit om de mate van fysieke activiteit en functioneel herstel na orthopedische chirurgie te verbeteren. Hospital Fit bestaat uit een smartphone applicatie verbonden met een accelerometer. Het maakt objectieve monitoring van fysieke activiteit mogelijk, geeft patiënten inzicht in de voortgang van het herstel en biedt een op maat gemaakt oefenprogramma. Er werd een pilotstudie uitgevoerd bij 97 patiënten die een totale knie- of heupprothese operatie ondergingen, waarbij gebruik werd gemaakt van een niet-gerandomiseerd quasi-experimenteel studie design. Patiënten in de controlegroep kregen de reguliere fysiotherapeutische behandeling, terwijl patiënten in de interventiegroep aanvullend gebruik maakten van Hospital Fit. Fysieke activiteit (tijd staan/lopen per dag) werd postoperatief gemeten met een accelerometer tot de dag van ontslag uit het ziekenhuis. Functioneel herstel op de eerste dag na de operatie (postoperatief dag 1: POD1) werd gemeten met behulp van de gemodificeerde Iowa Level of Assistance Scale (mILAS). Hospital Fit gebruik, gecorrigeerd voor leeftijd, resulteerde in een gemiddelde toename van 28,43 min (95% betrouwbaarheidsinterval (BI): 5,55-51,32) staan en lopen op POD1. Bovendien was de kans op het bereiken van functioneel herstel op POD1, gecorrigeerd voor de American Society of Anesthesiologists classificatie, 3,08 keer hoger (95% BI: 1,14-8,31) bij Hospital Fit gebruik. Deze pilotstudie toont aan dat Hospital Fit de potentie heeft om de mate van fysieke activiteit en functioneel herstel van patiënten tijdens ziekenhuisopname te verbeteren.

In hoofdstuk 6 is een accelerometer algoritme geoptimaliseerd en gevalideerd dat onderscheid kan maken tussen sedentaire (liggen/zitten), staande en dynamische activiteiten (lopen), en dat transitie van lig/zit naar staan/lopen kan registreren bij patiënten tijdens een ziekenhuisopname. Accelerometer data werd tijdens de ziekenhuisopname onder normale dagelijkse omstandigheden verzameld zonder

een activiteitenprotocol te volgen. Accelerometer data werden vergeleken met video analyse bij orthopedische patiënten en acuut opgenomen oudere patiënten. Gegevens van 25 patiënten werden gebruikt om het algoritme te optimaliseren, gegevens van nog eens 25 patiënten werden gebruikt voor de validatie. Optimalisatie resulteerde in de beste prestatie met parameterinstellingen: WS 4 s, PA Th 4,3 tellingen per seconde, SO Th 0,8 g. Validatie toonde aan dat het algoritme alle activiteiten binnen aanvaardbare grenzen classificeerde (>80% sensitiviteit, specificiteit en nauwkeurigheid, $\pm 10\%$ meetfout), behalve het classificeren van staan. Het geoptimaliseerde algoritme wordt geschikt geacht om fysieke activiteiten bij patiënten tijdens een ziekenhuisopname te kunnen classificeren.

In de algemene discussie in hoofdstuk 7 worden de belangrijkste bevindingen en methodologische overwegingen van dit proefschrift besproken. Verder worden implicaties voor de klinische praktijk en aanbevelingen voor toekomstig onderzoek gepresenteerd.

Concluderend kan worden gesteld dat dit proefschrift heeft geleid tot een beter inzicht in alle factoren die van invloed zijn op het beweeggedrag van patiënten tijdens een ziekenhuisopname. Het heeft een waardevolle bijdrage geleverd aan het verbeteren van het beweeggedrag van patiënten tijdens een ziekenhuis-opname.



ADDENDUM

ABOUT THE AUTHOR

ABOUT THE AUTHOR

Hanneke Corine van Dijk - Huisman was born on March 6th, 1984 in Meppel, the Netherlands. She attended secondary school at Almere College, Kampen (1996-2003) and completed one year abroad at Burnaby Central Secondary School, Burnaby, Canada (2000-2001). After graduation, she studied Physiotherapy at Fontys Hogescholen, Eindhoven (BSc. 2007). Her professional career as a physiotherapist started in geriatric rehabilitation centre Wissehaege, Eindhoven. In 2008, her interest in research made her combine her work as a physiotherapist with pursuing a master's degree in Human Movement Science (Physical Activity and Health, Biology of Human Performance and Health) at Maastricht University, Maastricht (MSc. 2010, Cum Laude).

Since 2011, Hanneke has been working as a hospital-based physiotherapist at Catharina Ziekenhuis, Eindhoven and Elisabeth-TweeSteden Ziekenhuis, Tilburg. She has extensive experience with inpatient rehabilitation. Between 2013 and 2014 she took a gap year to travel around the world. In 2017, she moved to Limburg to combine her interest in clinical physiotherapy and research at the Department of Physiotherapy in the Maastricht University Medical Centre (MUMC+). Her PhD research focused on stimulating physical activity in hospitalised patients. Her supervision team consisted of Prof. dr. Ton Lenssen and Prof. dr. Rob de Bie. From 2019 on, she combined this with working as a project coordinator for 'Nutrition and Physical activity'-related healthcare innovations at the MUMC+ Healthcare Innovation Lab. In 2022, she completed her PhD and continued working as an embedded scientist at the Department of Physiotherapy and project coordinator at the Healthcare Innovation Lab. She lives in Vijlen with her husband Bart and kids Tijn and Yfke.



ADDENDUM

DANKWOORD

Toen ik op deze baan wilde solliciteren vroeg mijn man of ik echt wilde promoveren. 'Weet je zeker dat dit is wat je wilt? Je hebt gezien wat promoveren inhoudt. Doe het nou niet. Je weet dat het zwaar gaat zijn en dat het niet altijd leuk is'. Uiteraard zijn er een aantal momenten geweest waarop ik aan dat moment terug heb gedacht en dacht 'Waarom heb ik toen niet gewoon naar hem geluisterd?'. Het was inderdaad niet altijd leuk en het was zeker wel eens zwaar. Maar van de beslissing om te gaan promoveren heb ik nooit spijt gehad. Ik heb de afgelopen vijf jaar namelijk ontzettend veel bijgeleerd, heel veel nieuwe leuke mensen ontmoet en hele mooie kansen gekregen.

TOELICHTING OP DE COVER

Ik heb mijn promotietraject wel eens vergeleken met een reis door de bergen. Na mijn eerste publicatie had ik het gevoel dat ik nog vier bergen moest beklimmen. Elke berg op de cover representeert dan ook een van de vijf publicaties. Elke studie heeft me andere dingen geleerd en andere inzichten geboden. Ook had elke studie een ander beloop en zijn eigen uitdagingen. Uiteindelijk was het doel niet alleen om de top van de berg te klimmen en een artikel te publiceren, maar heeft de reis me ook doen groeien als onderzoeker en als persoon.

'It's not the mountain we conquer, but ourselves'

Sir Edmund Hillary

De vijf bergen op de cover heb ik uitgekozen omdat het bergen zijn die Bart en ik op onze wereldreis zijn tegengekomen. Vanaf de achterzijde gezien is de eerste berg van links Mount Ngauruhoe (2291m.), een vulkaan in Tongariro N.P., Nieuw-Zeeland. Deze vulkaan staat beter bekend als Mount Doom uit Lord of the Rings. Door alle losse stenen klommen we steeds twee passen omhoog en gleden we er weer eentje omlaag. Ook dachten we rookwolken uit de vulkaan te zien komen en hoorden we gerommel. Later hoorden we dat het leger van Singapore verderop met een oefening bezig was. De zware klim was het uitzicht echter helemaal waard, zeker toen er ook nog een huwelijksaanzoek volgde.

De tweede berg is Ama Dablam (6812m.) in Nepal. We waren al ruim een week onderweg op een trektocht naar Mount Everest Base Camp. Toen we Base Camp bereikten was het mistig en konden we de bergen om ons heen niet goed zien. We sliepen die nacht in een dorpje op 5164m. en stonden na een gebroken nacht om 3 uur 's ochtends op om samen met onze gids naar 5550m. te klimmen voor een mooi uitzicht op de top van Mount Everest. Toen het licht begon te worden en de mist weg was, zagen we pas goed waar we waren. We waren al zo hoog, maar de bergen om

ons heen torende nog steeds heel hoog boven ons uit. Een onbeschrijfelijk gevoel en een van de mooiste bergen die we bij het opkomen van de zon zagen was Ama Dablam.

De derde berg is Sagarmatha, oftewel Mount Everest (8848m.). Voor ons was dit de eerste keer dat we op grote hoogte wandelden, een hele bijzondere ervaring in een supermooie omgeving. We hadden maar heel weinig spullen bij ons, maar kwamen wel met een rugzak vol herinneringen terug. Maar het was ook een tocht waarin we geleerd heb wat de gevaren van hoogteziekte en wandelen in de bergen kunnen zijn. Het belang van gezond blijven, eten en drinken en een plek om te slapen stonden tijdens die tocht veel meer centraal dan normaal.

De vierde berg is Cradle Mountain (1545m.). Deze berg kwamen we tegen op de eerste dag van de Overland Track, een zeven daagse tocht door de Tasmaanse wildernis. Toen we vertrokken was het zonnig en 25 graden, toen we de volgende ochtend wakker werden lag er overal sneeuw. De overige dagen heeft het alleen maar geregend en liepen we soms tot onze kuiten door het water. Ondertussen waren er boven ons twee vogels aan het vechten om een slang. Heel fijn.

Als laatste komt Torres del Paine in Patagonië, Chili, aan de beurt. Een ontzettend mooi en ruig gebied met gletsjers die verder strekken dan je kunt zien. We hebben hier zoveel mooie natuur gezien, maar ook nog meer respect gekregen voor de bergen en de natuur. De muizen die door de tent heen knaagden waren niet zo erg, maar het waren de felle windstoten die ons nachtenlang wakker hielden. Midden in de nacht hielden we regelmatig de tentstokken vast omdat we bang waren dat de tent het zou begeven. Toen na ongeveer een week wandelen er een dikke boom vlak naast onze tent was omgewaaid en we niet wisten of we veilig een bergpas over zouden kunnen komen zonder ingesneeuwd te raken hebben we het opgegeven. Omdat we het niet meer veilig vonden zijn we omgedraaid.

De bergen op de cover zijn niet alleen symbolisch voor mijn promotietraject, maar ook voor de reis die patiënten meemaken tijdens een ziekenhuisopname. Voor de meeste patiënten is het vooruitzicht gelukkig mooi en is de opname een reis om weer beter te worden of naar huis te kunnen. Het ziektebeloop kan soms echter grillig zijn en leiden tot complicaties of (onverwachtse) tegenslagen. Elke patiënt bewandelt tijdens de opname zijn eigen pad waarin hij begeleid wordt door zorgprofessionals, medepatiënten of naasten. De wandelpaden op de cover representeren het beweeggedrag van patiënten tijdens een ziekenhuisopname. Zo kan er bijvoorbeeld verschil zitten tussen het beweeggedrag van patiënten met een geplande opname ten op zichte van patiënten met een acute opname. Ook kan dit beïnvloed worden door hoe lang iemand al ziek was en hoeveel hij voor de ziekenhuisopname bewoog.

DANKWOORD

Maar nu wordt het eindelijk tijd voor het echte dankwoord. Want ik had dit de afgelopen vijf jaar niet kunnen doen zonder de hulp van een heleboel mensen om mij heen. Vrienden, familie, collega's en patiënten, jullie hebben allemaal op een andere manier bijgedragen aan dit proefschrift door me verder te helpen op onderzoeksgebied of door er op een andere manier voor me te zijn. Een aantal mensen wil ik in het bijzonder bedanken.

Allereerst wil ik alle patiënten en zorgprofessionals bedanken die deel hebben genomen aan mijn onderzoek. Ondanks dat deelname aan de studies jullie niet altijd zelf iets opleverde waren jullie toch bereid om mee te doen om hiermee toekomstige patiënten mogelijk te kunnen helpen. Bedankt daarvoor en voor alle mooie gesprekken.

Daarnaast wil ik uiteraard mijn promotieteam bedanken.

Beste Ton, ik heb de afgelopen jaren ontzettend veel van je geleerd. We hebben heel veel leuke discussies gehad over ziekenhuisfysiotherapie en onderzoek doen. Vanaf het begin af aan heb je me vrijgelaten in mijn promotietraject en me het vertrouwen gegeven dat ik het kon. Ook op de momenten waarop ik daar zelf over twijfelde stond je voor me klaar en had je goede adviezen. Niet alleen op onderzoeksgebied, maar ook halverwege de zwarte piste; mijn bochten linksom gaan inmiddels een stuk beter. Je deur staat altijd voor ons open. Hoe druk je het zelf ook hebt, je maakt altijd even tijd voor ons promovendi. Bedankt voor de fijne begeleiding, maar uiteraard ook voor alle andere leuke momenten zoals fietstochtjes, teamuitjes, het WCPT in Genève en de ski-reis naar Serfaus.

Beste Rob de Bie, ook jou wil ik bedanken voor de fijne begeleiding en voor alles wat ik van je heb geleerd. Ook jij stond altijd voor me klaar als ik vragen had of advies nodig had, al moet ik bekennen dat ik je advies over flitsers iets minder betrouwbaar vind. Het ging tijdens onze maandelijkse overlegmomenten vaak over bitterballen, scheurende asfaltplaten, en het feit dat het ergens op de wereld wel vier uur is. Jij en Ton vulden elkaar qua kennis en begeleiding op de juiste momenten goed aan. Jullie opbouwende kritiek heeft de studies beter gemaakt maar mij ook doen groeien als onderzoeker. Jullie hebben me nooit enige druk opgelegd en hadden er ook oog voor dat het met mij als persoon ook goed bleef gaan tijdens mijn promotietraject. Bedankt daarvoor, dat waardeer ik echt.

Beste leden van de beoordelingscommissie en de corona, beste prof. dr. Karin Faber, prof. dr. Hans Savelberg, prof. dr. Jos Schols, dr. Karin Valkenet, prof. dr. Philip van der Wees, dr. Thomas Hoozeboom, prof. dr. Jan Hamers en dr. Ingeborg

Vriens. Bedankt dat jullie interesse in mijn proefschrift hebben getoond en de tijd hebben genomen om dit proefschrift te lezen, te beoordelen en/of te opponeren.

George, Ton, Lex, Jona en Aniek. Dankzij jullie sta ik hier nu. Toen ik zeven maanden zwanger was en bij jullie op sollicitatiegesprek kwam kon ik alleen maar hopen dat jullie verder konden kijken dan die dikke buik. Ik ben jullie heel dankbaar dat jullie dat gedaan hebben en dat jullie me deze mooie kans gegeven hebben.

Dr. Danielle, Dr. Aniek, Dr. Christel, Marissa, Anouk, en Loes (oftewel de Roze Veulens). Wat was het fijn en gezellig om meerdere promovendi te hebben op de afdeling. Het was super om samen te kunnen sparren over zowel onderzoeks-gerelateerde als iets minder onderzoeks-gerelateerde onderwerpen. We hebben inmiddels zo'n vier of vijf werkplekken gehad en ontzettend veel gezellige koffie- en (high-)thee momentjes. Helaas werd dit in coronatijd minder, maar het is wel heel leuk dat dit nu op de nieuwe onderzoekskamer weer terugkomt.

Meiden van 'Zorg dat u beweegt', het was super om met jullie de eerste beweegprojecten op te pakken en samen te sparren over wat we wilden gaan doen en hoe we het vervolgens gingen pilot-testen, evalueren en implementeren. Samen hebben we ook de patient journey en de infographic met de beweeginterventies vormgegeven. Ondanks dat we tegen allerlei uitdagingen aanliepen was het vooral ook erg gezellig. Het is dan ook jammer dat ZDUB door organisatorische redenen niet meer bij elkaar is! Lieke, we missen je nog steeds maar ik ben blij dat je het bij mijn oude collega's in het Catharina Ziekenhuis ook goed naar je zin hebt!

Mandy, bedankt voor al je hulp met includeren van patiënten, opplakken en afhalen van MOXen. En dat soms op de raarste locaties. Het was niet alleen gezellig om met je samen te werken, maar ook leuk om met je te kunnen sparren en om samen het bewegen op B5 te promoten. Daarnaast ook bedankt dat je Petra vanuit de geriatrie fysiotherapie opleiding mee hebt genomen naar het MUMC+!

Petra, ook jij bedankt voor je enorm harde werk en alle uren die je meegeholpen hebt aan het afnemen van interviews, transcriberen en coderen van de data. Het was een ontzettende klus, maar je bleef altijd vrolijk en samen hebben we ons door alle data heen geworsteld.

Rachel en Rik, het was heel handig om twee post-docs op de afdeling te hebben die al de nodige ervaring hadden met METC-aanvragen, accelerometers, en promoveren in het algemeen. Ik heb veel van jullie geleerd (o.a. dat ik Rik niet moet uitdagen met bergop fietsen), maar vond het vooral ook gezellig om samen te werken aan de validatiestudie, de Hospital Fit RCT en de Academisch Alliantie Fonds studie.

Rob Roomans, bedankt voor al je geduld en vertrouwen. Ook jouw deur staat altijd open voor een luisterend oor. Hoe kritisch we ook zijn, we kunnen het altijd met je bespreken (waarschijnlijk zolang het maar niet meer over verwerkers-overeenkomsten en goedkeuringen van de medisch technische commissie meer gaat). Je hebt ons de afgelopen jaren altijd gesteund en gefaciliteerd rondom onderzoek doen, Hospital Fit en andere beweegprojecten en dat waardeer ik.

Alle overige collega's van de afdeling Fysiotherapie, bedankt voor alle leuke momenten in de afgelopen jaren en al jullie hulp bij de diverse onderzoeken en projecten. Ik ben vijf jaar geleden in een heel leuk team terecht gekomen. Ondanks dat ik na mijn zwangerschapsverlof en verhuizing naar Limburg op een nieuwe plek moest beginnen heb ik me bij jullie meteen op mijn plek gevoeld. Alle leuke feestjes en teamuitjes hebben daar natuurlijk wel aan bijgedragen! Want zoals Jacky Baggen altijd zegt: 'Oontspanne moot ouch gebäöre!' Appie, bedankt voor al je social support! Als rechterhand van Ton voelde je altijd feilloos aan wanneer er wat morele steun nodig was. We zullen je binnenkort gaan missen! Frank, danke veur alles jong! Ich ving ut sjiek das dich geprobeerd höbst um mich Mestreeeuchs te lieëre! Victoire, Ilse en Wilke, bedankt dat jullie altijd voor iedereen klaarstaan! Ed, wat zal ik zeggen... iets met schildpadden, goudvissen en E(r)dingers... De rest van het Serfaus groepje, ik kan maar drie woorden zeggen: boeken, boeken, boeken.

En zo zou ik jullie het liefst allemaal persoonlijk willen bedanken voor de leuke of speciale momenten die we samen hebben meegemaakt. Nogmaals bedankt voor alle hulp bij het informeren van patiënten, het opplakken of afhalen van MOXen, het invullen van enquêtes, het meewerken aan interviews, etc. Zonder jullie had ik dit echt niet gekund!

Alle collega's van het Zorg Innovatielab, bedankt dat ik sinds 2019 ook onderdeel van jullie enthousiaste en leuke team ben mogen zijn. Esther, bedankt dat je ons 'Zorg dat u beweegt' clubje destijds gestimuleerd hebt om het beweegborden project en andere beweeginitiatieven op te pakken, waardoor we nu een structureel onderdeel van ZIEL zijn geworden. Ruud, bedankt dat je mijn sparringsmaatje was, voor al je lekkere taarten, en dat we het gerust geregeld oneens met elkaar konden zijn. Perry, Eric, en Desiré bedankt voor jullie hulp bij Hospital Fit! Roy, bedankt dat ik altijd aan de bel mag trekken! Evelyn en Nicole, jullie zijn een goed team en ik ben benieuwd waar jullie ZIEL in de toekomst heen gaan brengen. En natuurlijk aan het hele team... jullie optimisme en drive om de zorg te willen verbeteren is super, en ik vind het heel gaaf om te zien wat er daardoor vanuit ZIEL allemaal bereikt is, o.a. op het gebied van Digitale Zorg.

Dr. Sven, dr. Niek, dr. Lotte, Petra, en Emily, zonder burn-out promoveren was ons motto. Daarnaast uiteraard ook om niet elkaars concurrentie te zijn maar juist samen te werken aan onderzoek naar het stimuleren van het beweggedrag van

patiënten in Nederland. Een fijne bijkomstigheid was dat het onderling ook nog goed klikte en altijd erg gezellig was! Een van de leukste momenten was samen in Genève op het WCPT. Ondanks dat sommigen van ons een ander pad in zijn geslagen hoop ik dat we toch nog lang contact zullen houden! Petra en Lotte, mijn leukste herinnering aan jullie was onze trip naar John Hopkins in Baltimore! Ons hotel was niet zo'n succes, maar met jullie in de kamer naast me voelde ik me een stuk veiliger! Emily, veel respect voor alles wat je al bereikt hebt en voor je doorzettingsvermogen en opgewektheid! Ik ben trots op je! Sven, het was heel gezellig (en leerzaam) om samen de scoping review uit te voeren. Maandenlang hebben we ons samen door alle data geworsteld en daar zaten regelmatig dagen tussen dat ik meer met jou gesproken heb dan met Bart. Niek, met je oranje bijbel was je de eerst van ons die gepromoveerd is. Het is super dat we samen een Academisch Alliantiefonds subsidie binnen hebben gehaald en ondanks alle uitdagingen nu volop aan het meten zijn. Het wordt wel weer eens tijd voor een (falafel-vrij) etentje en om ook die fietstocht eindelijk eens plannen.

De afgelopen vijf jaar hebben veel zorgverleners of afdelingen binnen het MUMC+ bijgedragen aan de verschillende studies of beweegprojecten. Van de diverse verpleegafdelingen tot de afdeling communicatie en de grafisch vormgeving. Ik kan jullie niet allemaal persoonlijk benoemen, maar wil jullie wel bedanken voor al jullie hulp en enthousiasme. In het bijzonder wil ik toch de verpleegafdeling Interne en Ouderengeneeskunde (B5) en verpleegafdeling Orthopedie (C4) bedanken voor de medewerking aan mijn studies. Daarnaast uiteraard de Stuurgroep Herstelvoeding en Beweging, omdat we met zijn allen hetzelfde doel nastreven. Verder uiteraard ook de Kliniek op Maat-groep op A5 (Heidi, Astrid, Ingeborg, Elske, Robbert, Erwin en Bianca), bedankt voor al jullie enthousiasme (en gezellige) dinsdag-ochtend overleggen.

Servicepoint Activity Monitoring, Maastricht Instruments, IDEE, MEMIC met in het bijzonder Freek, Jos, Wouter, Kenneth, Cyriel, Koert en Iwan. Bedankt voor de prettige samenwerking van de afgelopen jaren. Door samen op te trekken hebben we subsidies binnen gehaald, Hospital Fit (door)ontwikkeld, een EPD-koppeling gecreëerd en samen artikels gepubliceerd. Special thanks daarbij aan Wouter, voor de fijne samenwerking in de validatiestudie en predictiemodel studie. Het was super om met alle vragen en problemen rondom algoritmes en accelerometers bij je terecht te kunnen en ik heb veel van je geleerd op het gebied van wearables en algoritmes.

Daarnaast zijn er nog een aantal partijen die ik speciaal wil bedanken. Allereerst alle co-auteurs van de diverse studies. Bedankt voor de prettige samenwerking en alle waardevolle input die jullie geleverd hebben. Vervolgens de vele stagiaires van de opleiding Fysiotherapie van Zuyd Hogeschool, van de

masters Human Movement Science en Health Policy, Innovation and Management aan de UM en van de opleiding Geriatrie Fysiotherapie van Avans. Bedankt voor al jullie hulp bij de diverse onderzoeksprojecten!

Ook wil ik Conny de Zwart, Jos Slangen en Mariëlle van Os van de afdeling Epidemiologie aan de UM kant bedanken voor alle ondersteuning!

Lieve familie en vrienden,

Ik heb veel van jullie de afgelopen vijf jaar minder gezien en gesproken dan ik eigenlijk wilde. Alle gezellige momenten met jullie vind ik erg belangrijk, maar helaas was dat door corona en de combinatie van promoveren en een druk gezinsleven niet zo vaak mogelijk als ik gewild zou hebben! Gelukkig weet ik dat het bij jullie niet uit maakt of ik jullie elke week zie of één keer per jaar... als we elkaar zien is het weer net als vanouds.

Helaas besloten sommigen van jullie ook nog eens naar de andere kant van de wereld te willen verhuizen! Yves, Monica and your little bogans, we miss you guys like crazy but hopefully we'll be able to come and visit you in Tassie soon.

Marloes, Maaike, Miranda (en aanhang), inmiddels zijn we al jaren van de opleiding fysiotherapie af, maar het blijft altijd gezellig. Miran, toen je voorzitter van het NVZF was het gezellig om elkaar regelmatig tegen te komen, met als highlight het WCPT. Maaike, we moeten echt vaker afspreken... ik heb genoten van ons weekendje kamperen! Marloes, van samenwonen in Hotel Goldstrike, samenwerken in het CZE tot mijn getuige zijn op de bruiloft... we worden echt oud! Bedankt dat je me zes jaar geleden op deze baan hebt geweest. Ook was het heel leuk dat je je master thesis vervolgens bij ons op de afdeling hebt uitgevoerd!

Leonie en Bas, helaas wonen we niet meer bij elkaar om de hoek, maar onze 11 over 11 momentjes blijven altijd leuk!

Mischa, Corinne, Femke, Moniek, Eline en Marit (en aanhang), ondanks dat onze Oktopus-tijd al ver achter ons ligt blijft onze band bijzonder en hebben we veel meegemaakt samen. Onze dates blijven altijd gezellig en het nachtje weg moeten we erin houden! Mijn speciale dank gaat uiteraard ook uit naar Ruben, voor het ontwerpen van mijn cover!

Levi en Lisa, hoeveel weekendjes weg zijn we elkaar nog verschuldigd? Het wordt tijd om ze eens te gaan innen.

Yvonne en Ellen, toen we nog buurmeisjes waren liepen we elkaar de deur plat. Inmiddels wonen we verspreid door het hele land en zijn dagjes afspreken

weekendjes logeren geworden in de schoolvakanties. Het is ook superleuk om te zien dat Tijn en Yfke het ook zo goed met Ruben kunnen vinden.

Ron en Tessa (en Nara en Mae), bedankt voor alle gezellige Vaya-momentjes samen! Ik kijk nu al uit naar de volgende wintersport samen.

Mark, Ronald, Arno, Ron en Tom... bedankt Koempels voor alle gezellige avondjes! Tijd om als vanouds weer wat te plannen?

Buurtjes, bedankt dat jullie het verhuizen naar Viele zo makkelijk gemaakt hebben! We voelen ons helemaal thuis hier en dat komt mede door alle gezellige avondjes samen!

De antraciete tijgers van H.V. Optimo (en uiteraard Gerold), jullie zorgden er wekelijks voor dat ik niet alleen patiënten aan het bewegen probeerde te krijgen maar ook zelf in beweging bleef. Ons team is (dankzij Gerold) de afgelopen jaren uitgegroeid tot een grote, gezellige groep en ik hoop dat dit zo blijft!

Mijn twee paranimfen, Carla en Mischa. Met jullie achter me weet ik dat het helemaal goedkomt.

Carla, ik ken je inmiddels al bijna 20 jaar en wat hebben we in al die jaren toch veel meegemaakt! Ontelbare verjaardagen en feestjes, van weekendjes weg naar de Ardennen tot samen naar de Galapagos, en heel veel koffie- en shopmomentjes, en playdates met de kinderen. Nu zitten onze kinderen samen in de klas en ben je de afgelopen jaren op vrijdag regelmatig mijn hulplijn geweest als ik weer eens net te laat op het schoolplein stond. Onder andere door jou en Ronald was het voor mij helemaal geen probleem om naar Limburg te verhuizen!

Mischa, wat zal ik zeggen. Ook jou ken ik al sinds 2003 met als eerste herinnering een Sinterklaasavond van EZSV Oktopus in het studentenhuis bij Corinne. Daarna volgden ontelbare handbaltrainingen bij Oktopus, studentenfeestjes, koninginnedag in Amsterdam, meerdere GNSK's, en samen handballen bij PSV. Wat hebben we samen veel gekkigheid uitgehaald. Ook al woon je nu aan de andere kant van de wereld, het maakt niet uit hoe vaak we elkaar zien, als we elkaar zien blijft het als vanouds. Ik kijk met heel veel plezier terug op onze vakanties in Qatar, Kuwait en Oostenrijk. Ik heb nu al veel zin om in de deze herfst samen met Corinne, Femke en onze gezinnetjes weer bij jullie in Kuwait langs te gaan en om de week na mijn promotie weer samen op wintersport te gaan. Ik vind het super dat je helemaal vanuit Kuwait hier naartoe gekomen bent om mijn paranimf te zijn! En mocht ik flauwvallen, dan heb ik het volste vertrouwen dat jij het zonder enige moeite van me over kunt nemen!

Lieve Onno, Esther, Bèr, Monique, Oscar en Simon, ik ben hartstikke blij met zulke leuke (schoon)broers en schoonzussen en twee lieve neefjes! Het is altijd gezellig met jullie!

Lieve Jeannine, ik kan je niet genoeg bedanken. Je staat altijd voor ons klaar en bij jou thuis voelt het als een tweede thuis! Wanneer we ook langskomen, het is altijd gezellig en er is altijd wel een lekkere zelfgemaakte maaltijd. Elke woensdag pas je op de kinderen en is het super dat wij na het werk gewoon kunnen aanschuiven en ook nog eens allerlei verse groenten, fruit en zelfgemaakte maaltijden mee naar huis krijgen!

Lieve papa en mama, bedankt voor jullie onvoorwaardelijke liefde en steun. Ondanks dat we ver uit elkaar wonen maken jullie toch elke maand de lange reis naar het zuiden om op Tijn en Yfke te passen (en stapels pannenkoeken te bakken). Papa, zonder jou zou ik nu niet gaan promoveren. Allereerst door alle uren die je me op de middelbare school hebt geholpen met wiskunde, scheikunde en natuurkunde. Daarnaast had ik het zonder het doorzettingsvermogen wat ik van jou en oma mee heb gekregen nooit gered!

Lieve Bart, bedankt dat je elke ochtend mijn brood smeert.

En natuurlijk dat je mijn fietsbanden regelmatig oppompt. En dat je mijn Excel-hulplijn bent. En voor het maken van de mooie bolletjes-figures in chapter three. En voor de afgelopen vijf jaar. Vooral voor de afgelopen vijf jaar. Want mijn beslissing om te gaan promoveren was voor jou niet altijd leuk, ook al weet je zelf uit eerste hand wat promoveren inhoud.

Alle uren die ik 's avonds naast je op de bank heb gezeten met de laptop op schoot. Het aanhoren van al mijn gemopper en frustraties. Ik heb het je niet altijd makkelijk gemaakt. Maar ondanks alles bleef je me steunen en stond je altijd voor me klaar. Je dacht met me mee en liet me vaak met een andere blik tegen problemen aankijken waardoor ik tot nieuwe inzichten of keuzes kwam. Je bracht me vele koppen thee, stukken chocola, glazen wijn en vooral veel knuffels. Zonder jou had ik dit niet gekund! Speciaal voor jou komt er daarom toch een 'Be that as it may' in mijn proefschrift te staan. Je weet hoeveel ik van je hou en hoeveel ik waardeer wat je allemaal doet! Bedankt dat je mijn beste vriend en de beste vader voor onze kinderen bent. Broodje kaas!

Lieve Tijn en Yfke, toen ik hiermee begon waren jullie een peuter van 2,5 jaar en een kleine baby van 4 maanden oud. Inmiddels zijn jullie grote kinderen van 7 en 5 jaar en kunnen jullie al lezen, schrijven, skiën en huttentochten door de bergen lopen! Jullie vinden het ziekenhuis ook heel interessant en zouden het liefst heel vaak mee gaan naar mama's werk. Door al jullie vrolijke kwebbels was het voor mij heel makkelijk om 's avonds en in het weekend te ontspannen en niet aan werk te

denken. Ik ben ontzettend trots op jullie en wil nog heel veel mooie nieuwe avonturen met jullie beleven. Ik hou van jullie!

Hanneke,
Vijlen, oktober 2022



ADDENDUM

LIST OF PUBLICATIONS

LIST OF PUBLICATIONS

1. van Dijk-Huisman HC, Weemaes ATR, Boymans T, Lenssen AF, de Bie RA. Smartphone App with an Accelerometer Enhances Patients' Physical Activity Following Elective Orthopedic Surgery: A Pilot Study. *Sensors* (Basel, Switzerland). 2020;20(15).
2. van Dijk-Huisman HC, Bijmens W, Senden R, Essers JMN, Meijer K, Aarts J, et al. Optimization and Validation of a Classification Algorithm for Assessment of Physical Activity in Hospitalized Patients. *Sensors* (Basel, Switzerland). 2021;21(5).
3. Geelen SJG, van Dijk-Huisman HC, de Bie RA, Veenhof C, Engelbert R, van der Schaaf M, et al. Barriers and enablers to physical activity in patients during hospital stay: a scoping review. *Syst Rev*. 2021;10(1):293.
4. van Dijk-Huisman HC, Raeven-Eijkenboom PH, Magdelijns FJH, Sieben JM, de Bie RA, Lenssen AF. Barriers and enablers to physical activity behaviour in older adults during hospital stay: a qualitative study guided by the theoretical domains framework. *BMC Geriatr*. 2022;22(1):314.
5. van Dijk-Huisman HC, Welters MHP, Bijmens W, van Kuijk SMJ, Magdelijns FJH, de Bie RA, et al. Development and internal validation of a prediction model to identify older adults at risk of low physical activity levels during hospitalisation: a prospective cohort study. *BMC Geriatr*. 2022;22(1):479.

